

U.S. Department of Justice *National Institute of Corrections*

**FIRE SAFETY
IN
CORRECTIONAL
FACILITIES**

ANNOTATED
EDITION

102418

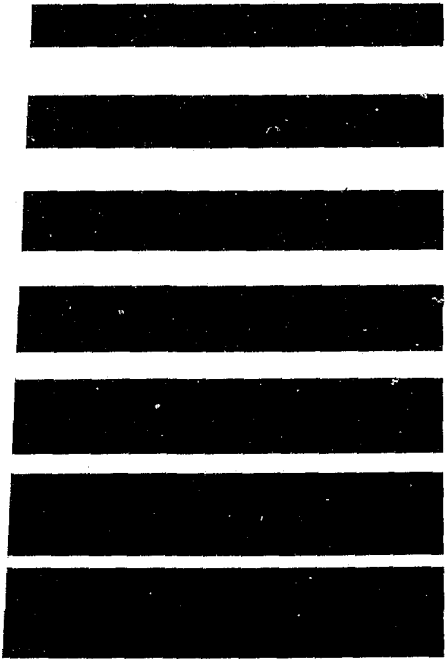

FIRE SAFETY IN CORRECTIONAL FACILITIES

ANNOTATED EDITION

**U.S. Department of Justice
National Institute of Justice**

This document has been reproduced exactly as received from the person or organization originating it. Points of view or opinions stated in this document are those of the authors and do not necessarily represent the official position or policies of the National Institute of Justice.

Permission to reproduce this copyrighted material has been granted by

Public Domain/National Institute of
Corrections/US Dept. of Justice

to the National Criminal Justice Reference Service (NCJRS).

Further reproduction outside of the NCJRS system requires permission of the copyright owner.

FOREWORD

Fire safety is of ever-increasing concern throughout our society. This is particularly true in correctional facilities, where security requirements necessitate specialized planning and procedures. The need to develop and implement sound policies and provide safe environments has been demonstrated too often by prison and jail fires that have resulted in loss of life, personal injury, and property damage.

The National Institute of Corrections has worked with the National Fire Protection Association to develop specialized training programs in fire safety for correctional facilities. These training materials are intended to assist correctional managers in assessing their fire safety needs, developing long- and short-range policies and procedures, and properly training their employees in fire prevention and emergency readiness.

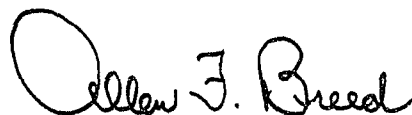

ALLEN F. BREED, Director
National Institute of Corrections
April 27, 1981

CONTENTS

Preface iv

Acknowledgments v

Notes to the Instructor vi

- 1 Fires in Correctional Facilities 1
 - 2 Using the Systems Approach to Deal
with the Fire Problem 15
 - 3 The First Goal: Ignition Control 28
 - 4 The Second Goal: Fuel Control 36
 - 5 The Third Goal: Occupant Protection 58
 - 6 The Fourth Goal: Detection and Suppression
Activities 75
 - 7 The Fifth Goal: Planning and Training
Operations 110
 - 8 Developing a Plan Using the Simplified System 124
- Appendix A Related Codes and Standards 145
- Appendix B Summary of Proposed Life Safety
Code Changes 147
- Appendix C Glossary 156
- Appendix D Bibliography 161
- Appendix E Chapter Review Answer Keys 162

NCJRS

AUG 25 1986

ACQUISITIONS

PREFACE

The prevention and control of fires in correctional facilities presents unique problems for those involved in the administration of these occupancies. Because the priority of corrections administrators is security, fire safety often receives little attention among decision-making personnel.

Over the past five years, however, the number of fatal fires in correctional facilities has brought these unique problems into sharper focus. It is evident that the particular nature of these occupancies makes them easy targets for large life and property loss fires. This inherent risk is complicated by an attitude among some corrections officials that security must be compromised in order to achieve fire safety.

The content of this educational manual is designed to increase the level of fire safety in local, county, and state correctional facilities throughout the United States by alerting the reader to the fire problem in these institutions and by providing information on how to achieve a fire safe environment without the loss of security. The manual will be most helpful to state facility and large jail administrators responsible for determining policies related to fire safety in their respective institutions but with little or no fire protection background.

The context in which information is presented is an overall fire safety system with direct application to the corrections environment. This information emphasizes proven measures which are financially, politically, and operationally feasible for both immediate and long-range implementation by corrections administrators.

The writing of this manual has been the direct effort of a very small group of people: Joseph C. Sala, author; Wayne G. Carson, technical consultant; Callie McDowell, instructional design consultant; Ruth L. Harmon, editor; Marguerite LaMonica, project secretary; Melissa Evans, word processing coordinator; and Austin R. Sennett, Director, Division for Continuing Education.

However, this manual and its annotated edition are the indirect effort of hundreds of members of the corrections community. They were the instructors and participants in a series of seminars developed for the National Institute of Corrections by the Division for Continuing Education of the National Fire Protection Association and conducted during the period of 1977 to 1981. Their enthusiastic reception of the seminar format and materials provided valuable insights into the operations of the corrections environment and resulting fire safety problems, as well as potential solutions. Their contributions are deeply appreciated.

Special thanks belong to the Southern Steel Company of San Antonio, Texas whose analytical undertakings provided us with the bulk of our technical information related to locking systems.

ACKNOWLEDGMENTS

This document was developed by the National Fire Protection Association under grant number BZ-0 from the National Institute of Corrections, U.S. Department of Justice. Its dissemination is encouraged in the interest of information exchange. The United States government assumes no liability for the contents or use thereof.

NOTICE

The contents of this document reflect the views of the National Fire Protection Association. The contents do not necessarily reflect the official views or policy of the National Institute of Corrections. This document does not constitute a standard, specification, or regulation.

NOTES TO THE INSTRUCTOR

This manual is intended to serve as a sourcebook for teaching fire safety in correctional facilities. As such, it contains both standard textual information and instructional annotations. The annotations address two groups of potential students: Level I, supervisory personnel; and Level II, line staff.

Annotations are numerically referenced in the text. Annotations function as teaching aids. They may enlarge upon self-instruction exercises already in the text or they may suggest additional group exercises or discussions, provide explanation, or offer tips on specific audiovisual materials that are available.

PROGRAM OBJECTIVES

The instructional method used in this manual presents a number of overall objectives as well as specific performance objectives at the beginning of each chapter. The objectives are aimed at increasing the level of fire safety within the context of security in local, county, and state correctional facilities throughout the United States. They include:

- To provide participants with an awareness of the fire safety problems unique to correctional facilities.
- To provide participants with a knowledge of the goals of a fire safety system and how these goals incorporate fire safety objectives.
- To provide participants with an awareness of fire codes and standards related to the overall fire safety system of a correctional facility.
- To provide participants with adequate knowledge of fire protection technology and its use in correctional facilities.
- To enable participants to evaluate the fire safety problem in an individual facility.
- To provide participants with practical means for increasing fire safety in order to achieve stated fire safety objectives.
- To enable participants to develop emergency operating procedures for dealing with correctional facility fires without compromising security.
- To encourage participants to improve relations with local and state fire authorities in order to increase efficiency and cooperation in fire prevention and control activities (Level I only).
- To enable participants to develop education and training programs for members of the corrections community including corrections officers, inmates, fire brigades, and administrators (Level I only).
- To provide participants with an awareness of those resource groups who can be contacted for further technical and financial assistance (Level I only).

- To encourage participants to take those steps necessary to improve life safety within the financial, legal, and operational constraints of a correctional facility (Level I only).

In order to ensure that students reach stated goals and objectives, the manual is based on a strict chapter structure. The chapters provide basic information, a method for organizing the course content, and exercises that can be used individually or in groups. The chapters follow a logical sequence; therefore, a working understanding of one chapter is a prerequisite for the next. It is expected that an instructor will take the basic information in the chapters and tailor it to the facility using it.

Throughout this program of instruction, the instructor is responsible for the overall management and delivery of the course. In this case the students serve as secondary resources. As the primary presenter of materials, the instructor will need to familiarize himself/herself with the course content and consult additional references as necessary. As manager, you will need to organize written and audiovisual materials, establish the classroom environment, and guide student discussions. For maximum student involvement, introduce students to the course by explaining what the course consists of, how it will be run, and what level of participation is expected of them. Following are some suggestions that can be used to facilitate each of these responsibilities.

Except for Chapter Eight, which covers long-range planning, all of the chapters are addressed to both Level I and Level II students. Chapters are arranged with an overview containing: a content summary, a listing of performance objectives, a listing of unfamiliar words, the content itself, and a chapter review. In addition, the headings which appear alongside the text function as an instructor's outline for the content.

Before beginning each chapter, review the performance objectives with students so that they understand what is expected of them. Also, review any glossary words that may be unfamiliar to students.

The most effective method of presenting this program of instruction is to supplement an instructor's lecture presentation with three additional components: a student workbook, audiovisual materials, and group discussions.

Experience has proven that increased student involvement results in greater initial learning and retention. In order to initiate

ROLE OF INSTRUCTOR

Deliver Information

Organize Written and Audiovisual Materials

and maintain student involvement, it is recommended that you develop a student workbook or work pages based on the suggestions which appear in the annotations. A highly structured format that encourages interactive notetaking will prove most beneficial. Within the annotations, suggestions for information to be included on a particular workbook page appear following this symbol. The organization and layout of this information is left to the discretion of the individual instructor.

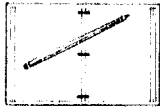

Workbook pages can also be used for problem-solving scenarios or case studies as a basis for group discussions. As a trainer and member of the corrections community, you can use your expertise and experience to write up short case studies which should always include: all pertinent facts, date and time of any incidents, a clear statement of the problem to be solved, and a time within which to solve the problem.

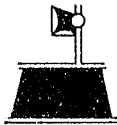

Another symbol which appears in the annotations suggests that an overhead transparency be used. In most cases, the information suggested for the transparency duplicates that for the workbook page. The transparency is suggested to help organize the instructor's presentation and to assist the students in completing their workbook pages. The simplest transparency can be made with a sheet of clear acetate and a transparency marking pen. For maximum readability, written information which appears on a transparency should be clear, concise, and simply presented.

Suggestions for available audiovisuals appear in the annotations. Slides, slide/tape packages, films, or transparencies are available from the following producers of fire protection materials:

Robert J. Brady Co.
A Prentice-Hall Company
Bowie, Maryland 20715

Film Communicators
11136 Weddington Street
No. Hollywood, California 91601
Toll Free: (800) 423-2400

Factory Mutual Engineering Corporation
1151 Boston-Providence Turnpike
P. O. Box 688
Norwood, Massachusetts 02062

National Fire Protection Association
Publications Division
Batterymarch Park
Quincy, Massachusetts 02269

Your local fire department, any large industrial plant with its own fire brigade, and the state fire training office may have copies of these materials which they would be willing to lend. Using materials from any of these local sources may prove valuable during any planning or training sessions.

Another readily available and effective source of slides is a 35-mm camera and slide film. Your own facility provides the greatest potential for audiovisuals that not only illustrate information but offer a means for applying that information to the everyday work environment.

Before each class, assemble all necessary materials including any reference materials which need to be ordered. Since use of the chalkboard is generally included in each unit, erasers and chalk should also be available. In some cases you may choose to complete group reporting procedures by using an overhead transparency. If you intend to use any audiovisuals, make sure that all equipment and materials are ready for use.

The physical set-up of the room is an important factor for attaining an atmosphere in which students are viewed as resources. There should be a working surface on which students can write. Preferably, round tables which seat up to eight persons should be used and each table should accommodate one working group. The tables should be arranged so that each student is able to view any visual materials, including the chalkboard. If available, additional reference materials, such as codes or standards, could be conveniently located in the room so that students may have ready access to them.

To achieve the greatest visual impact of slides, films, or overhead transparencies, try to obtain a facility with black-out blinds. If no such room is available, set up the screen so that light enters the room from behind it. The screen should be of a height visible to all students. All equipment should be set up and checked before the class enters. Slides, films, and overhead transparencies should be previewed before they are shown to the students to ensure that all materials are complete and that you are prepared to discuss and comment on them. The projector should be in proper working condition, and the slides to be viewed should be properly positioned in the machine. Having the equipment ready for use promotes an efficient and well-managed atmosphere. It is always advisable to keep extra projector bulbs on hand.

There are numerous references to group discussions in the annotations, indicated by the symbol shown here. Generally, groups should be kept small. When group work is specified, divide the class into groups with a maximum of four or five persons per

***Establish the
Classroom
Environment***



***Organize and Manage
Group Discussions***

group. However, if the number of groups exceeds the number of topics to be discussed, more than one group can work on the same problem. In this case, make sure that each group has a chance to report on the exercise.

Since group discussions are frequent, it is important that students feel comfortable with each other. Should your classes include both Level I and Level II students, allow class members an opportunity to interact and establish a rapport with each other.

During group exercises and discussions, your job as manager is to make certain that students understand and work toward the objectives specified under the particular group exercise. Several ideas that may help you in keeping discussions centered are:

- Recognize that any group of adults has expertise and experience which they want to share, and which can be explored and applied to the problem at hand.
- Reflect any queries for your own opinion back to the group for response.
- Encourage equal participation by all members of the group. This can often be accomplished by calling on new people by name rather than waiting for volunteers.
- Address any comments you may have to the large group or smaller groups rather than to individuals.
- When individuals respond, avoid judgmental comments such as "good" or "not true." Rather, put the question of agreement or disagreement to the group.
- React with acceptance and without evaluation, showing only that you understand or need clarification.
- Avoid an extended digression by asking someone to relate it to the main point.
- Handle repetition by summarizing and making a transition to new topics.
- Prevent confusion and eliminate disagreement by narrowing the scope of differences and recognizing that differences in judgment are possible.
- Remind group of any time limits so it can consider all aspects of a problem.

Chapter One

FIRES IN CORRECTIONAL FACILITIES

What does it mean when we talk about "the fire problem in correctional facilities"?

Clearly, jails, prisons, detention centers, and similar buildings differ from most institutional occupancies because security is a major operational consideration. The ways in which this difference has shaped the history of fire in correctional facilities is the focus of this chapter. The chapter will present: an overall history of the problem; individual case summaries; common characteristics of fires in correctional facilities; the impact of the security factor; and a unit review.

After reading this chapter and completing the exercises as directed by the text, you will be able to do the following:

- Describe how the nature of fires in these facilities has changed over the years.
- List four characteristics common to fires in these facilities.
- Identify the most common source of ignition for incendiary fires in correctional facilities.

Before beginning this chapter, you may want to use the glossary to review any of the following terms with which you are not familiar.

combustibles
fuel configuration
incendiary
means of egress
untenable

OVERVIEW

1. It is assumed that students will have already been informed of the basic contents of the course, how it will be presented, and what level of participation is expected of Level I and Level II students. If necessary, repeat this information. Students should be made aware of exactly what to expect from the course.

2. Since fire safety traditionally ranks low among the priorities of corrections officials, establish clearly and firmly the extent of the fire problem in correctional facilities. Impress on the students that there is a fire problem in correctional facilities and that the information in this course will help them to correct the problem in their facilities.

2. Students should understand exactly what level of performance is expected of them after completing each chapter. If students do not have some type of workbook in which the objectives for each chapter are listed, read or explain the objectives to them.

3. Before beginning this and subsequent chapters, students should be familiar with the terms listed in the overview section of each chapter. One approach is to ask for volunteers to define the words. Another method would be to have students locate definitions in the glossary.

HISTORY OF THE PROBLEM

4. This section puts the fire problem in correctional facilities in historical perspective. A number of fires will be discussed in limited detail. When you are presenting this section be certain students recognize some of the problems (e.g., combustible interior finishes, synthetics) that they may encounter in their particular facilities.

If unlimited time for class preparation exists, the fires themselves and related photographs can be researched through state departments of corrections, the National Institute of Corrections, or the National Fire Protection Association.

5. Students should understand that you are not advocating abandoning security in favor of fire safety and fire protection. You recognize that security is their number one priority. However, fire safety must share in this priority. The history of fire in correctional facilities points out the problems (in deaths) that have occurred because fire safety was not a priority.

The devastating fire at the Ohio State Prison in Columbus, Ohio, which killed 320 inmates in 1930, made it clear that a serious fire problem existed in correctional facilities. At that time, prison construction was often wood frame, most notably frame roof structures. Once a fire started, it consumed these structures with ravaging intensity. Builders, fire protection engineers, and fire service personnel applied modern technology and the multiple fatality fire problem in correctional facilities was solved.

Or was it? Nearly thirty years later, during the 1960s and 1970s, the multiple fatality fire problem in correctional facilities returned with a vengeance. Solutions, however, were no longer as simple. New types of fuels created fires unlike those fed by ordinary combustibles.

During the 1960s and 1970s, correctional facilities were entering the era of synthetics. Synthetic materials, including polyurethane foam and styrene-butadiene foam rubber, were used to manufacture furnishings such as mattresses and padding panels in cells. Combustible interior finishes helped to make the correctional environment less harsh and more civilized. Stark, blank reinforced concrete security walls were disguised behind facades of thin plywood paneling, reinforced plastic paneling, or other combustible materials. Combustible suspended ceilings were installed to create a more humane environment.

One of the fires that illustrated this change in the fuel configuration of correctional facilities occurred in June 1975 at the Seminole County Jail, Florida. Ten inmates and one correctional officer suffocated in the toxic smoke of burning polyurethane mattresses. This fire was one of the tragedies that ushered in the new breed of multiple fatality fires in correctional facilities.

As the fuel configuration in correctional facilities changed, creating new fire problems, the combination of other deficiencies — single means of egress, unreliable locking and evacuation systems, lack of automatic or manual fire suppression capabilities, lack of early warning fire detection, and the high frequency of incendiary fires — completed the grim scenario for tragedy.

Beginning with a multiple fatality prison fire on June 21, 1977, the fire safety problem in correctional facilities exploded with death and destruction. In a period of two and a half weeks, three multiple fatality fires occurred: one in the City Detention Center in St. John, New Brunswick; one in the Maury County Jail, Columbia, Tennessee; and the last in the Federal Correctional Institution in Danbury, Connecticut. The total death toll from the three fires was sixty-eight people.

Clearly, the fire problem in correctional facilities is tragic. An initial step toward solving this problem is to analyze the fires and note major characteristics that occur in fire after fire. We have already mentioned a specific fuel type — namely, polyurethane



Polyurethane mattresses stored outside the cell were the materials first ignited at the Seminole County Jail in Sanford, Florida. (Credit: Sentinel Star Journal)

mattresses — as the cause of many multiple fatality fires. Other aspects that can be evaluated for common characteristics are the type of act, the source of ignition, the place of origin, and the degree of security. This chapter will briefly describe eleven fires that have occurred over the years in correctional facilities and you will note some of their common characteristics. Later chapters will discuss specific measures that can be used to reduce or eliminate the problems presented by each characteristic.

The following summaries describe eleven fires in correctional facilities. Before continuing, remove Table 1.1, "Common Characteristics of Fires in Correctional Facilities," and place it alongside this manual. As you read each summary, fill in the appropriate information on the chart. It is important to be as specific and complete as possible when filling in the chart. When it is complete, the chart will provide you with a quick overview of the major losses and common characteristics of each fire.

During the late afternoon and evening of Monday, April 21, 1930, a raging fire swept through the north wing cell blocks of the Ohio State Penitentiary at Columbus. To date, it is the worst fire catastrophe to take place in a correctional facility in this country. A total of 320 inmates lost their lives and 133 others received injuries which might have eventually caused death or permanent disability. While the resultant property damage was comparatively small, the various circumstances surrounding this fire and the appalling loss of life forcibly called attention to the potential tragic hazards to life and property present in institutions of this

6. This chart should form the basis of your presentation of the eleven fires in correctional facilities. Thus, the discussion of each fire should include: date of fire, facility, and location of the facility; major losses; type of act; ignition source; place of origin; fuel; and any problems in evacuation. It is this information that students should have in their notebook or workbook. Overhead transparencies that can be completed by you during the discussion of each fire would be helpful.



OHIO STATE PENITENTIARY
Columbus, Ohio
April 1930

Losses
Type of Act
Ignition Source
Place of Origin
Fuel
Evacuation Problems

CASE SUMMARIES

COLUMBUS, OHIO

April 1930

Table 1.1

COMMON CHARACTERISTICS OF FIRES IN CORRECTIONAL FACILITIES

DATE, FACILITY AND LOCATION	MAJOR LOSSES	TYPE OF ACT (Incendiary or Accidental)	FUEL TYPE	PLACE OF ORIGIN	PROBLEMS IN EVACUATION
April 1930 Ohio State Penitentiary Columbus, Ohio					
July 1967 State Road Camp Berrydale, Florida					
March 1968 Oregon State Penitentiary Salem, Oregon					
October 1974 Youth Correctional Center Cranston, Rhode Island					
June 1975 Seminole County Jail Sanford, Florida					
November 1975 Lycoming County Jail Williamsport, Pennsylvania					
June 1976 Marion State Prison Marion, North Carolina					
June 1977 Maury County Jail Columbia, Tennessee					
June 1977 Saint John City Detention Ctr. St. John, New Brunswick					
July 1977 Federal Correctional Institute Danbury, Connecticut					
December 1979 Lancaster County Jail Lancaster, South Carolina					
Most frequently observed characteristic of each category.					

kind. This gruesome reality emphasized the need to provide greater safeguards for the inmates in all facilities.

The large loss of life was due to the fire in a wood roof building where a great number of inmates were concentrated. The large undivided area of the building, the lack of detection or suppression systems, and the combustible roof construction afforded ideal conditions for the rapid spread of fire. The loss of life was exaggerated because inmates were confined in cells with individual locks. Add the fear of mutiny among the inmates and the lack of emergency procedures which delayed opening the locks, and the scenario for tragedy is complete. Although the fire department's response was prompt, the headway which the fire gained before the fire fighters arrived indicates that considerable delay occurred either in the discovery of the fire or in sounding the alarm.

Fifty-one prisoners were housed in a wood frame dormitory building of a state road camp when an evening disturbance broke out. Inmates set a fire at the opposite end of the single, heavily barricaded exit from the building. A wall exhaust fan near the fire helped to increase its intensity.

When the fire was discovered, officers went to get weapons from an arms cabinet in the office. This delayed the release of prisoners for about nine minutes because the same key to the gun cabinet also opened the single exit. The delay ended in tragedy for thirty-eight inmates.

During a riot, inmates took control of a major portion of this correctional facility. They set several fires in six separate buildings in the prison compound. The rioting inmates would not allow the responding fire fighters to attack the fire. One of the six buildings, a furniture factory, was the only building protected by an automatic sprinkler system. The sprinkler system controlled this fire until its water supply was interrupted. Damage amounted to an estimated \$1.5 million.



**BERRYDALE,
FLORIDA**

July 1967

SALEM, OREGON

March 1968

The fire that consumed this wooden prison barracks in Berrydale, Florida, left thirty-eight prisoners dead — the largest loss of life in a single fire in the United States or Canada in 1967. The metal cage in the foreground was the guard station. (Credit: The Press Gazette)

**CRANSTON,
RHODE ISLAND**

October 1974

In the recreation room of a maximum security facility for a youth correctional center, seven male juveniles barricaded the main entrance door with a pool table and ignited several polyurethane foam cushions from the chairs and sofas. Due to the rapid build-up of heat and smoke, the room became untenable in a matter of minutes. The correctional officers could not release the juveniles through the main exit; the alternate exit was behind a locked fence. Only after a delay in obtaining the key were the officers able to unlock the alternate exit and rescue five boys who were at that door. By then the fire department had responded. Several fire fighters wearing self-contained breathing apparatus entered the building and evacuated the other two boys. The fire was quickly extinguished by fire fighters and confined to the area of origin. One of the last two boys evacuated died shortly after arrival at the hospital; the other boy succumbed several days later.

**SANFORD,
FLORIDA**

June 1975

A juvenile set fire to polyurethane mattresses stored outside his cell in this two-story county jail. One of two correctional officers on duty attempted to get standpipe hose to fight the fire, while the other guard went to report the fire and get additional help in releasing prisoners. By the time he returned with help, the smoke and heat were so intense that the men were driven back after releasing only three prisoners and inadvertently leaving cell keys in one lock.

Arriving fire fighters equipped themselves with self-contained breathing apparatus, searched for the lost keys and evacuated the remaining prisoners. They found the first correctional officer's body with the second set of cell keys. In addition to the one officer who died, ten prisoners lost their lives from smoke inhalation injuries during this incident.

**WILLIAMSPORT,
PENNSYLVANIA**

November 1975

About 12:30 a.m. in the juvenile detention cell of this concrete and stone correctional facility with solid steel doors, six juveniles ignited the mattresses from their beds, probably as part of an escape plan. The juveniles gave the guards an early alarm on the emergency call system. However, because of previous false alarms, the calls were ignored. Guards were thus unaware of the rapid buildup of smoke and heat from the polyurethane-foam mattresses and did not respond immediately. Once rescue attempts began, guards delayed sounding the alarm to fire fighters. Three of the six juveniles died before fire fighters arrived. Compartmentation helped to prevent death or serious injury to prisoners in other areas.

**MARION,
NORTH CAROLINA**

June 1976

This one-story institution housed sixty-seven prisoners in two dormitory cells. Several of the thirty-six prisoners in one dormitory cell ignited sheets and blankets with matches to protest the confiscation of two radios. A prison guard ordered the

prisoners to put the fire out. As the guard returned to his desk, the inmates threw several polyurethane mattresses on the fire. The fire expanded rapidly, and was out of control within minutes. Only then did the five correctional officers on duty open the four exits and release the men to the recreational yard. A total of nine inmates died from injuries they received during the incident. An additional twenty-four were injured, and approximately \$50,000 worth of property was damaged.

It was afternoon visiting hours in the Maury County Jail. This institution, constructed of fire-resistive material, housed sixty-five inmates and contained the sheriff's office. A fire of apparently incendiary origin started in a cell padded with both styrene butadiene and urethane foam padding. Along with the inmates, several visitors were locked in the cell block area. Severe smoke conditions rapidly developed after the occupant of the cell of origin was removed, and the door to the padded cell was left open.

In the rush to release people, the jailer's keys were dropped and temporarily lost in a smoke-filled corridor, delaying evacuation. Several persons were removed as fire fighters breached an exterior masonry wall and cut steel bars to provide a means of egress. Thirty-four inmates and eight visitors died; thirty-one other people were injured by the fire. Damage to the jail was moderate, with the fire being confined to the padded cell.

Rapid buildup of smoke and heat from polyurethane mattresses and a delayed alarm to fire fighters resulted in the deaths of three juvenile inmates in this Williamsport, Pennsylvania juvenile detention cell.



Severe smoke conditions developed in the Maury County Jail from a fire that began in a padded cell that had both styrene-butadiene foam padding with neoprene and urethane foam padding with a polyvinyl cover. Thirty-four inmates and eight visitors died. (Credit: Columbia Daily Herald)



**COLUMBIA,
TENNESSEE**

June 1977

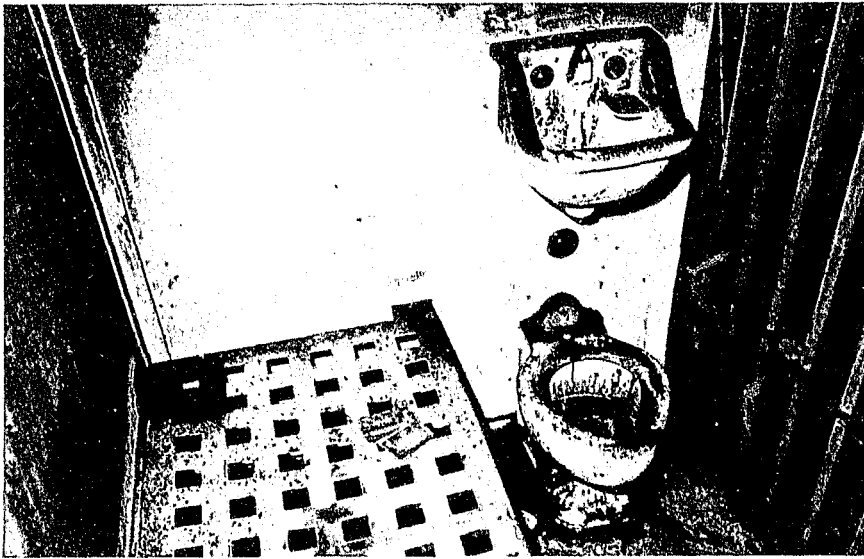

Foam rubber padding and plastic covering on walls, floor, and ceiling were the primary fuels of the fire at the City Detention Center in St. John, New Brunswick.

**ST. JOHN,
NEW BRUNSWICK**

June 1977

At the time of this late-night incident, approximately twenty-seven inmates were housed in the main cells of the detention center. The fire started in a padded cell where the primary fuel involved was foam rubber padding and plastic covering on the walls, floor, and ceiling. The detention center was equipped with heat and smoke detectors and manually activated fire alarm boxes. An alarm was automatically sounded to the fire department if either the detectors or manual box was activated.

Despite rapidly developing thick smoke, the correctional officers were able to remove an inmate from the padded cell where the fire started. Correctional officers made an initial attempt to fight the fire with a standpipe hose, but they were quickly forced out of the area by the intense heat and smoke.

Fire fighter response was rapid. This was due to the direct connection of the alarm system to the fire alarm center, and the location of the fire apparatus only a few blocks away. The intense heat and smoke, however, resulted in death for twenty-one inmates and injuries for fourteen other people, including inmates, police, correctional officers, and fire fighters.

**DANBURY,
CONNECTICUT**

July 1977

An early morning fire occurred in a dormitory unit of a federal correctional institution that was of fire-resistive construction. Eighty inmates were housed in the 40-by-80-foot area.

The fire, apparently incendiary, was ignited in a washroom near the primary means of egress from the dormitory. The alternate means of egress became unusable when a key broke off in the door lock. The fire's initial growth, with rapid flame spread and heavy smoke, involved fiberglass reinforced plastic wall paneling and its plywood backing. The fire was confined to the general area of origin in the washroom. Fire fighters were hindered in reaching the fire due to the security measures required at the institution, including several gates that were opened by different keys. No single guard had keys to every gate or door that had to be opened.

In sum, both the type of fuel and the lack of prefire planning led to the tragic results of this fire: five inmates dead; eighty-six inmates, correctional officers, and fire fighters injured.

This structure, which was located atop a building listed in The National Register of Historic Places, contained no automatic sprinkler protection, no heat or smoke detector systems, no manual alarm system, no emergency lighting, and no emergency unlocking mechanisms. Moreover, the jail had no visual monitoring systems and, even worse, no second means of egress.

Although the source of ignition was undetermined, events preceding the fire point to an incendiary cause. Once ignited, stored combustible materials, bedding, inmates' clothing, and cleaning products, which were all stored together, produced heat and smoke that quickly made the entire jail area untenable. Fire damage involved the stored material and combustible contents of the nearby cells.

Despite quick work by a trustee and, later, fire fighters, a stubborn padlock, combined with the intense heat and smoke, frustrated efforts to free inmates. In addition to eleven deaths, four fire fighters, two police officers, and the trustee were injured in the rescue attempt.

**LANCASTER,
SOUTH CAROLINA**

December 1979

This washroom in the Danbury, Connecticut correctional facility was near the primary means of egress from the dormitory. The fire's initial growth, with flame spread and heavy smoke, was due to fiberglass reinforced plastic wall paneling and its plywood backing. (Credit: John Mongillo, Jr., New Haven Register)



7. Although these two fires, especially the riot at the New Mexico State Penitentiary, make for interesting discussions, be certain to point out that the surrounding circumstances are beyond the scope of this course.

7 Two other significant fires in correctional facilities are worth noting. On January 30, 1979, a natural gas combustion explosion destroyed a wing of a building housing a farm equipment repair shop of the United States Federal Penitentiary in Leavenworth, Kansas. Six inmates and one staff member were killed, and two farm staff members were injured. On February 2, 1980, it was "hooch" that provided the fuel for the bloody and savage riot at the New Mexico State Penitentiary in Santa Fe, New Mexico. Thirty-six hours later, thirty-three inmates lay butchered in the ruins. Damage caused by fires and the unrestrained madness was estimated at \$22 million.

Why are neither of the two disasters just described included in the main part of our discussion of the common characteristics of fires in correctional institutions?

Each of these disasters, while significant in both loss of life and property damage, are beyond the scope of this discussion. The introduction pointed out that the major focus of this manual is inmate occupancies — residential, assembly, and educational. The explosion at the United States Federal Penitentiary at Leavenworth took place in a farm equipment wing which is part of an industrial area. Even more specialized is the case of the New Mexico State Penitentiary tragedy. The fire safety system discussed in this manual is not intended to apply to fires resulting from riot situations.

COMMON CHARACTERISTICS OF FIRES IN CORRECTIONAL FACILITIES

8. The conclusions drawn about the most frequently observed characteristics should come from students. Give students about one or two minutes to review their notes. Then ask for volunteers to give responses in the following categories: type of act; fuel type; place of origin; problems in evacuation. Students should understand the significance of these common

8 Now that you have completed Table 1.1, use the information summarized from the case histories to draw conclusions about the most frequently observed characteristic in each category.

As the completed Table 1.1 indicates, the frequency of incidence of certain common characteristics in these eleven correctional facilities fires is significant. Your table should show that:

- Almost all fires were incendiary, some arising from riot situations.
- Except for the initial three fires in these case summaries, the fuel types were synthetic materials — specifically polyurethane mattresses, foam rubber cushions and padding, and, in one instance, fiberglass reinforced wall paneling. Along with inmates' clothes, these materials

would be the common fuel available in cells and cellblock areas.

- The inmate housing areas, i.e., cells and cellblocks, were the place of origin in most of the eleven fires studied.
- Finally, in the majority of these incidents, there were significant complications resulting from some aspect of security. Archaic locking systems, lost keys, no second means of egress and, especially, lack of emergency evacuation procedures contributed to serious problems in evacuating inmates.

After noting these common characteristics, what general conclusion can be drawn about fires in correctional facilities?

From these common characteristics among the eleven cases presented, it is clear that fires in correctional facilities present special problems both in fire prevention and fire suppression.

In an effort to identify and study these problems, the National Fire Protection Association reviewed the reports of 52 fires in correctional facilities from January 1967 through July 1977 (see Table 1.2). A summary of these reports, contained in *A Study of Penal Institution Fires*,* identifies significant common characteristics of correctional facilities fires and fire protection. These common characteristics, many of which have been identified in Table 1.1, are grouped into several categories: type of act, source of ignition, fuel type, place of origin, and security aspect.

The statistical information of this study points to a familiar scenario — or as NFPA researchers describe it — a “model” correctional facility fire. The “model” correctional facility fire is of incendiary origin and is started in a cell. The fire principally involves building contents, as opposed to structural materials. Further, this “model” fire generates intense heat and dense smoke that quickly invade all corridors and adjoining areas, hindering safe evacuation of the occupants. Does this scenario sound familiar? It has occurred in fire after fire in correctional facilities.

As Table 1.2 illustrates, 45 out of the 52 fires (87 percent) were incendiary in nature.

**A Study of Penal Institution Fires*, Boston: National Fire Protection Association, 1977.

characteristics: it is these areas, specifically, that must be addressed in any fire safety program in a correctional facility.



COMMON CHARACTERISTICS OF FIRES IN CORRECTIONAL FACILITIES

Type of Act
Fuel
Place of Origin
Evacuation Problems

9

9. Ask for student responses to this question.

10 STATISTICAL STUDY

10. LEVEL I: The NFPA study is simply a review of the discussion on the common characteristics of fires in correctional facilities. There is no need to spend any more than two or three minutes summarizing the findings of the NFPA report. However, supervisory personnel should be aware that such a study has been conducted.

11

11. A discussion of a “model” correctional facility fire serves as an excellent review of this chapter. Explain to students that you want to use the information discussed in this chapter to describe a “model” correctional facility fire. Ask for students to volunteer a description of a “model” correctional facility fire.

MOTIVES FOR INCENDIARY FIRES

Table 1.2
STATISTICS OF PAST
CORRECTIONAL FACILITY FIRES*

Category	Number of Incidents
<i>Type of Act</i>	
Accidental	7
Incendiary	45
<i>Source of Ignition</i>	
Welding	1
Boiler	1
Electrical Equipment	3
Smoking Materials	27
Unspecified	17
<i>Fuel Type</i>	
Mattresses	25
Cell Padding	5
Clothing	11
Paper Products	5
Wood Roof or Floor	2
Flammable Liquid	3
<i>Place of Origin</i>	
Cells	33
Recreation Room	4
Boiler Room	2
Storage Area	4
Cell Blocks	6
Penal Work Buildings	3
<i>Security Aspect (Problem in Evacuation)</i>	
Prompt Evacuation	6
Insufficient Access	2
No Available Key to Locked Door	4
Insufficient Emergency Training	6
No Second Means of Egress	5
Not Indicated	29

*Adapted from Tables 1-6, *A Study of Penal Institution Fires*, Boston: National Fire Protection Association, 1977, pp. 1-3.

From your experience, what do you think are the motives for the incendiary fires in correctional institutions?

Although the conclusions of the National Fire Protection Association study cannot be applied to all incendiary fires in correctional facilities, the predominant motives reported were: to increase chances of escape, to cause malicious damage as a protest against conditions, to show force during a riot, or to commit suicide.

In every incendiary incident where the source of ignition was positively identified, either a match, smoking material, or cigarette lighter was used to ignite the fire. The study shows that this is to be expected, since such ignition materials are the ones most readily available to inmates.

**SOURCE OF
IGNITION**

Principal materials first ignited were those that are found in a prison cell—mattresses, bedclothes, and personal clothing. Again, this is not surprising, since seventy-five percent of all the fires studied originated in the occupants' cells. Finally, in many of the fires there were significant delays in evacuation resulting from some aspect of security.

PLACE OF ORIGIN

It is clear that incendiarism is a significant factor in correctional facility fires. Too much emphasis can be placed upon the incendiary factor, however, as an excuse for not pursuing fire protection alternatives. In fact, the rate of incendiarism in corrections is not that significantly higher than the rate in other occupancies.

Regardless, it is still imperative to reduce both the number and severity of these fires. As will be discussed in subsequent chapters, to achieve this goal it is necessary to strengthen both fire prevention and protection methods, i.e., supervision, construction, preplanning, suppression equipment, detection, and others. The next chapter will discuss how a systems approach provides an integrated method of analyzing fire protection problems and developing fire protection and prevention programs. First, let's review.

The review sections of this manual provide an opportunity for you to measure your understanding of the information contained in each chapter. Try to answer each question without looking back through the chapter. Then check your response by referring back to the appropriate section in the chapter.

1. Contrast the type of fuels involved in correctional facility fires of the 1930's with the type of fuels involved in fires of the 1960's and 1970's.

.....
.....
.....
.....

2. List four characteristics common to most fires in correctional facilities.

a.

- b.
- c.
- d.

3. In most incendiary fires in correctional facilities, the source of ignition has been:

- a. welding torch
- b. smoking materials
- c. extension cords
- d. unspecified

4. In most incendiary fires in correctional facilities, the materials first ignited have been:

- a. flammable liquids
- b. wood floor or roof
- c. cell padding
- d. mattresses

12. These questions can serve as a review for the material covered in each chapter or, in combination with other review sections, as a total review or posttest for the complete course. Be certain that the questions used are appropriate for Level II, Level I, or both.

Chapter Two

USING THE SYSTEMS APPROACH TO DEAL WITH THE FIRE PROBLEM

The systems approach organizes and documents the way in which we think about a problem. The extensive use of synthetic materials has created additional fire problems in structures, including correctional facilities. These facilities present the additional concern of maintaining security. Although the public deserves protection from convicted criminals, inmates deserve the same protection from the ravages of fire as workers in high-rise office buildings. The systems approach to fire protection in corrections will help to achieve both security for the public and safety for inmates by a systematic analysis of each problem area and the application of available technologies to improve fire safety in correctional facilities.

This chapter will define what is meant by a systems approach to fire protection; discuss how the systems approach is used; and show how the Simplified Fire Safety System for Correctional Facilities has been designed to help deal with fires in these occupancies.

After reading this chapter and completing the exercises as directed by the text, you will be able to do the following:

- Define the term "system."
- Describe three attributes of a system.
- State the basic rationale for using a systems approach.
- List three advantages of using the systems approach for solving problems.
- Identify the fire safety objectives and the major goals of the Simplified Fire Safety System for Correctional Facilities.

OVERVIEW

1. Use this overview as an introduction to the chapter. Students should understand from the very beginning that they do not have to be fire protection engineers to understand and use the systems approach for increasing the level of fire safety in their facilities.

2. Students should be familiar with the objectives of this chapter.

3. Since these words are very much a part of the language (jargon) of systems and the systems approach, in addition to defining them, review them as they appear in the chapter. This will give students a context for using and understanding the words.

4. Since this definition will be referred to throughout the chapter, write it out on a chalkboard or overhead transparency for continual reference.

DEFINITION OF A SYSTEM

5. Allow students to note some of the important points while you are explaining the basic attributes of a system. Assure them that the definition and the attributes will become clearer as the discussion proceeds.

INTERACTIVE

DYNAMIC

6. Use this question as a means of generating class response.

3 Before beginning this chapter, you may want to use the glossary to review any of the following terms with which you are not familiar.

feedback
input
output
subsystem
system

4 Before considering how the systems approach is applied to the fire problem, it is necessary to define what is meant by the term "system." For the purposes of this discussion, a system is the organization of interacting components in such a way as to carry out a predetermined function or reach specified objectives.

5 There are three basic attributes of a system: interactive, dynamic, and identifiable.

As stated in the definition, a system consists of individual components or elements, each selected for its potential to interact with other components while performing a specific function. The interaction of these individual or specific functions is required in order to attain the stated objectives. The system's ability to reach its stated objectives arises from its design and performance as a total entity.

Systems try to fulfill their goals by performing operations and interacting within themselves. This does not mean that to be dynamic a system must be constantly or even frequently active; a system does not cease to be a system because it assumes a standby status.

Can you suggest a system related to the fire protection of a building that is in a standby status?

An automatic sprinkler system is a building system that is in a standby status. It may be on standby alert for virtually all of its operational existence and may not become functionally active until a fire occurs within its area of coverage, which may never happen. Not every component of a system needs to be active for the system to be dynamic. In planning the fire extinguishing operations for a structural fire, interactions are intended to occur be-

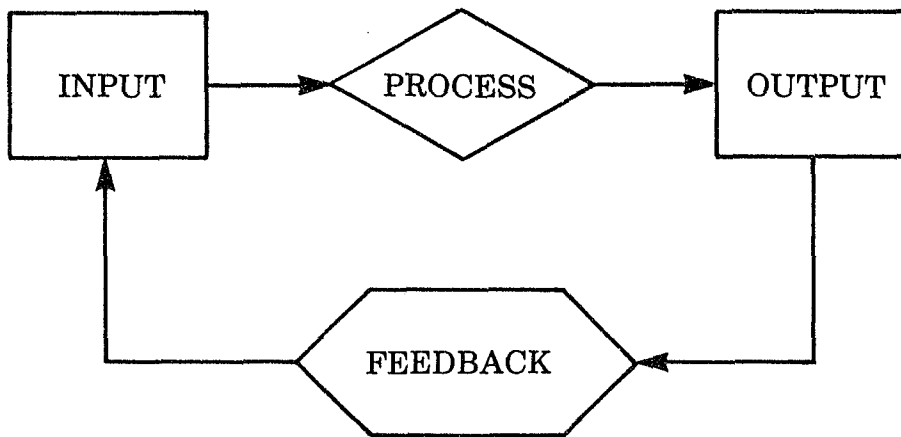

Figure 2.1 Basic System Model

tween the “passive” fire-resistive structural building materials and the “active” fire suppression agents and equipment.

Once a plan takes form in the preliminary design, it can be identified as a system. What is identified as the system includes only those components and processes that are controlled by the system. This ability to be identifiable as part of the system provides significant advantages when it is used as a problem-solving tool, as will be discussed later in this chapter.

The basic reason for using the systems approach is that it allows a detailed investigation of a large number of problems and their potential solutions. The systems approach is a method of organizing the thought process to review all of the problem areas, and analyze potential solutions. Of particular importance is the ability to determine the effect of any one solution to a particular problem on the other problem areas. The overall design of the systems approach is based on the operational theory of the computer (see Fig. 2.1). A system such as a computer processes *input* (facts of the situation) into *output* (usable data) consistent with the stated objectives. To make sure its stated goals are achieved, the system continuously evaluates its performance by monitoring the outputs, a process referred to as *feedback*.

An automobile engine aptly illustrates how a system functions. The engine, actually a system itself, consists of many interactive components: for example, a carburetor, which provides the correct mixture of gasoline and air; spark plugs; pistons; camshaft; valves; crankshaft; alternator; assorted wires; and a radiator, which cools the engine. The dynamics of this system work to provide energy to the drive train. According to Figure 2.1, the car engine receives input (gasoline and air), processes this input, and then transforms it into the output which is usable mechanical energy for the drive train.

IDENTIFIABLE

USING THE SYSTEMS APPROACH

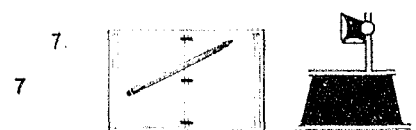

Use Figure 2.1 to illustrate overall design of a system.

8. This example should answer many of the questions students may have regarding the functioning of a system. You may be able to offer another example of a system, such as the body, or you may want to solicit responses from the students.

9. Using the example of the automobile engine, ask students to cite several ways in which a driver is notified that the engine may not be working as expected.

10. LEVEL I: A brief discussion of the three advantages of using a systems approach is useful for supervisory personnel. They may be able to suggest other advantages from their own experience.

ADVANTAGES OF SYSTEMS APPROACH

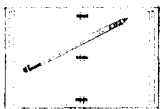

ADVANTAGES OF SYSTEMS APPROACH

- 1.
- 2.
- 3.

11



LEVEL I

Concept: Idea of a system can be clarified by having students identify specific systems.

Activity: Request that each group identify a system. It is better if they limit their scope to simpler systems, e.g., a security system, or even a system similar to an automobile engine, rather than a complex system such as an educational system or the corrections system. For their system each group must be able to: 1. Include a short description of several of the major components of the system; 2. Justify the system in terms of its being interactive, dynamic, and identifiable; 3. Identify the major problem the system is designed to solve; 4. Describe the operation of the system: input, output, the way the system uses feedback to evaluate its output; 5. Alter one of the components of the system and describe its effect on the other components and on the performance of the system as a whole (use the example of the automobile that is driven at high altitudes).

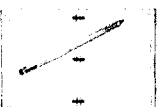

IDENTIFYING A SYSTEM

Description of System
Major Problem
Operation
System Alteration

If, for any reason, a system does not produce the intended objective, feedback will provide the basis for redesign of one or more of its components. Let's say that the automobile engine experiences an unusually heavy load, for example, the car hauling a trailer. A load this taxing may cause the engine to overheat. The radiator, which was designed only for cooling the engine under normal driving conditions, is now unable to handle the abnormal amount of heat. The system does not work as expected or needed, as manifested by the overheating of the engine (the feedback).

Because any discussion of a system should highlight the system's potential value as a tool for analyzing and solving problems, let's consider the advantages a systems approach brings to these tasks. First, the systems approach provides an organized way of looking at problems. A system is the result of a systematic and scientific planning effort. By design, a system presents a well-defined and well-executed method for solving a problem. All components and processes operate within an organized framework (or design) of the system.

Second, the systems approach incorporates all significant, interacting components when it attempts to solve a problem. As mentioned previously, the value of a system is its ability to organize through interaction. By this is meant that the activity of any component of a system has some effect on the activity of every other component. Moreover, when changes are made within the system, whether or not the changes are deliberate, they are evaluated only after the combined effect of the changes and their interactions with the performance of the total system has been assessed. This is different from evaluating the effect of the changes on only one component or process of the system. The systems approach solves problems in relation to the total system rather than in relation to isolated components. The systems approach intentionally expands its domain of consideration until all the significant, interacting components are included, and this is a distinct advantage in problem-solving.

An automobile engine again serves as a convenient example. When an automobile is driven at high altitudes, a change is made within the system of the engine; namely, the rarefied air alters the gasoline-air mixture in the carburetor (which is presumably adjusted for normal sea-level altitudes). The net effect on the operation of the system — i.e., the engine — is reduced performance. The problem is solved in relation to the effect on the total system rather than in relation to the carburetor only. This may include adjusting, or even replacing, the jets of the carburetor and changing the ignition timing. Thus, the solution to the problem involves all significant interacting components of the system.

The third advantage of using the systems approach is that it provides a means to determine the most cost-effective solution.

Because the components and processes of a system can be identified, it is possible to analyze the cost involved using different solutions. By manipulating the components on paper, their effects on the system as a whole can be examined without actually setting up the system. Because the systems approach makes it possible to evaluate the cost of each item or solution to the problem, the best solution for the least cost can be identified.

Systems and the systems approach to solving problems is not new. For years, high technology, rapidly expanding industries (for example, aerospace and military defense), and the field of education have used the systems approach to solve their problems. The shift to the systems approach has had its skeptics; but its advantages and unlimited potential have been compelling enough to win them over.

Fire protection engineers began using the systems approach in fire protection in 1971. At that time, the General Services Administration committed itself to developing a total systems approach to fire safety for federal high-rise buildings.* Some of the concepts that led to the fire safety systems for high-rise buildings were that: total evacuation is impractical; fire fighting access is limited and difficult; new materials of construction present different fire problems.

The National Fire Protection Association also worked on the problem of fire safety in high-rise buildings. NFPA's response was a systems approach applicable to all types of buildings — a fire safety system derived through a decision tree network. This network is called the Fire Safety Concepts Tree.

In developing a systems approach to fire safety in correctional facilities, we will be using a simplified version of the Fire Safety Concepts Tree. It will be helpful to first take a look at the Concepts Tree itself (see Fig. 2.2)**.

This complex array of rectangles and symbols is a diagrammatic means of illustrating how a system — specifically, a fire safety system — operates.

What is the definition of a system?

*Arthur F. Sampson, "Life Safety for High-Rise Structures," *Fire Journal*, Vol. 65, No. 4 (July 1971), p. 8.

**For an in-depth discussion of the Fire Safety Concepts Tree see Robert J. Thompson, "The Decision Tree for Fire Safety Systems Analysis," a three-part series in *Fire Journal*, July, September, and November, 1975.

EVOLUTION OF SYSTEMS APPROACH TO FIRE PROTECTION

12

12. LEVEL I: Keep the discussion of the evolution of the systems approach to fire protection brief.

FIRE SAFETY CONCEPTS TREE

13

13. LEVEL I: A brief discussion of the Fire Safety Concepts Tree will give Level I students a better grasp of the operation of the Simplified Fire Safety System for Correctional Facilities. However, before beginning your discussion be certain all students have a copy of the Fire Safety Concepts Tree. An overhead transparency of several of the components that are used in explaining the operation of the Concepts Tree would also benefit your discussion. Individual copies of the Concepts Tree are available from the National Fire Protection Association. The diagram is also included in the 14th edition of the *Fire Protection Handbook*, published by NFPA.

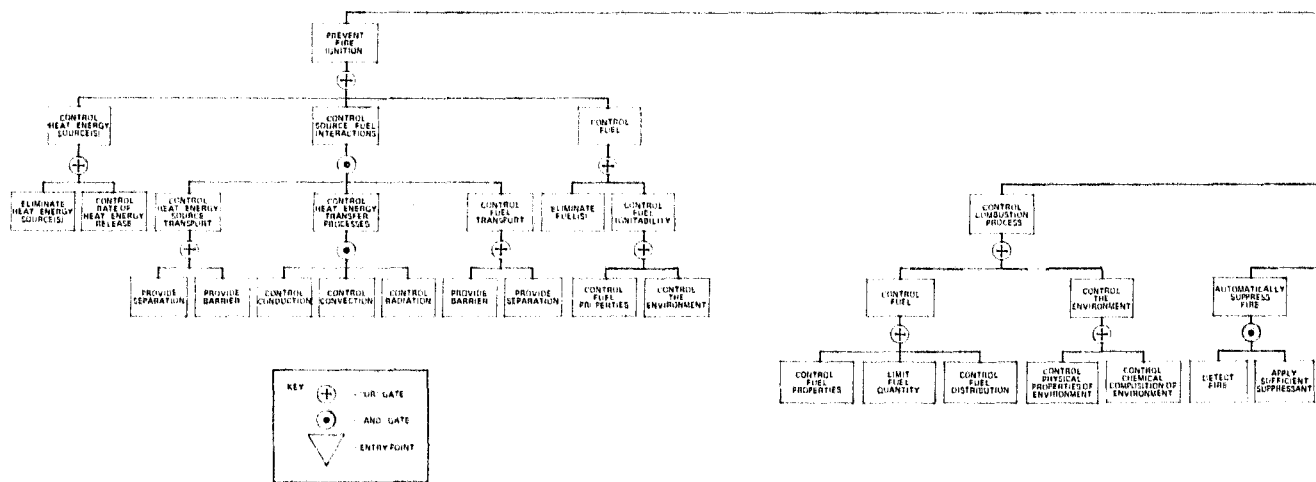





Figure 2.2. Fire Safety

As previously stated, a system is the organization of interacting components, designed to carry out a predetermined function or to reach specified objectives.



System Overview





The network diagram of the Fire Safety Concepts Tree consists of two basic parts: (1) decisions and (2) results or events. In the Concepts Tree, each box represents an event. Each event acts as both a *goal* for the events below it and a *method* to obtain the event above it. All of the events branch out from the first goal event like the limbs of a tree and show the possible results of a number of decisions.

 is a method event for which goal event above it?

 is a method event for the goal event .

At the same time,  is the goal event for which two method events below it?

 is the goal event for the methods events  and .





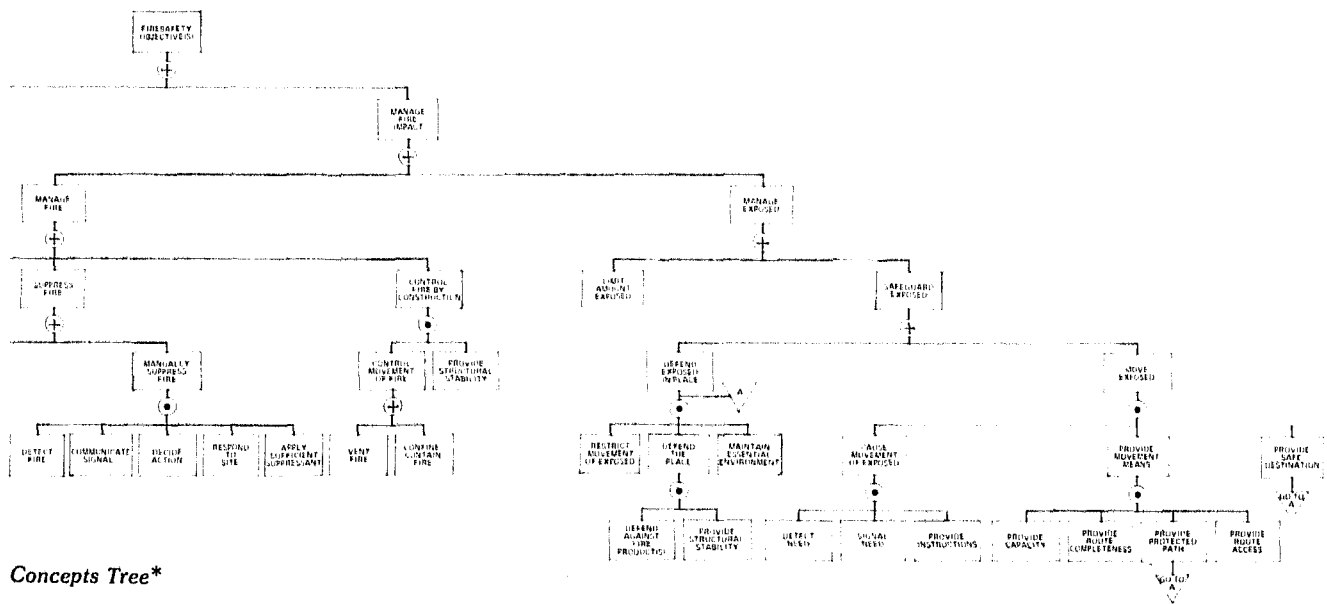

In the same manner,  is both a method event for  above it and a goal event for  and  below it, and so on.

The ways in which the events interact are represented by what is termed the "and" gate (symbolized by a dot within a circle — ◉) and by the "or" gate (symbolized by a plus sign within a circle — ⊕). An "and" gate means that for the goal event to be successful,



Concepts Tree*

all method events in the sequence must occur. An "or" gate means that only one of the method events must occur for the goal event to be successful. Let's use an event from the last example.

For the goal event  to be successful, either the method event  or the method event  must occur. On the other hand, for the goal event  to be successful, all of the method events  and  and  must occur.

According to the definition of a system the interacting components must reach specified objectives. In the Fire Safety System, the Fire Safety Concepts Tree structure expresses and emphasizes the interrelationship between the various events that, working together, lead to the fire safety objectives. These objectives (the ultimate goal event) appear at the top of the Fire Safety Concepts Tree and may be one or all of the following: safety to life, protection of property, continuity of operations.

Defining and quantifying these objectives may be the most difficult task of designing the system. The type of occupancy, available funds, NFPA 101®, Life Safety Code®,† and many other considerations impact on the achievement of fire safety objectives.

The same type of thinking that produced the Fire Safety Concepts Tree system for planning fire protection in buildings motivated the development of the Simplified Fire Safety System for Correctional Facilities.

* Copyright 1980, National Fire Protection Association

†Life Safety Code and 101 are registered trademarks of the National Fire Protection Association, Inc.

14. The Simplified Fire Safety System for Correctional Facilities is basic. To be able to apply the system to their facilities, they must understand the system completely from the beginning.



Figure 2.3

System Objectives

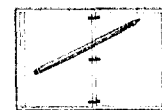

SIMPLIFIED FIRE SAFETY SYSTEM FOR CORRECTIONAL FACILITIES
 Similar to Figure 2.3, except include definitions of each goal. Allow writing space for defining each fire safety objective and for writing methods related to each goal.

SIMPLIFIED FIRE SAFETY SYSTEM

Note: Direct students to underline key words when you are reading the definitions of each goal and to write in the definitions of each fire safety objective and each method as they are discussed.

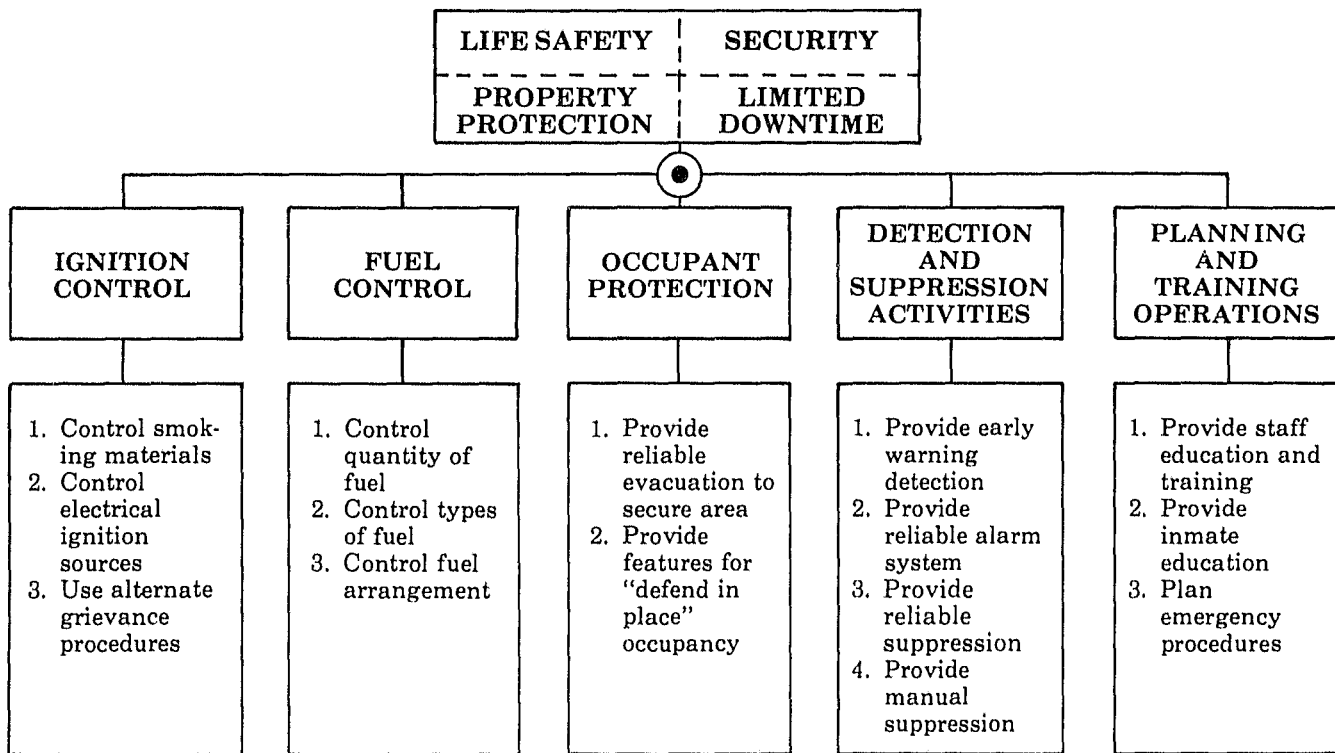

Figure 2.3 Simplified Fire Safety System for Correctional Facilities

BASIC COMPONENTS

15. LEVEL I: Briefly show how the Simplified Fire Safety System is derived from the Fire Safety Concepts Tree.

A careful study of the Simplified Fire Safety System (see Fig. 2.3) will show that the system, although simplified, is derived directly from the fire safety system that is represented by the Fire Safety Concepts Tree. It consists of the same basic components: objectives, goal events, decisions, and method events. For simplification, the terminology in Figure 2.3 has been altered slightly, as will be explained later.

RATIONALE

16. Impress upon students the importance of consulting a fire protection engineer, especially during the planning stages of designing a fire safety system for their particular facilities.

The rationale for presenting a Simplified Fire Safety System is one of utility. Because the Fire Safety Concepts Tree was designed for use by fire protection engineers, its application purposely includes all types of structures. On the other hand, the simplified system presented here is designed to be used by corrections managerial/supervisory personnel responsible for fire safety in correctional facilities. Of course, it is good practice to consult a qualified fire protection engineer during the planning stages of any fire safety system, especially when objectives are being set and quantified.

OBJECTIVES

As with any system, the Simplified Fire Safety System for Correctional Facilities has objectives. In this case, there are four objectives: life safety, property protection, limited downtime, security.

According to the definition of a system, how are these objectives attained?

The components of the system interact, that is, they work together, to attain these fire safety objectives. As mentioned previously in the discussion of the Fire Safety Concepts Tree, much time can, and should, be spent defining and quantifying these fire safety objectives. However, for now it is sufficient to understand the need for these objectives in fire protection.

Life safety relates to the protection of individuals from death or injury by fire. Property protection includes protecting both the facilities themselves and their contents from fire. Downtime indicates a break in the continuity of operations. It is comparable to the term "business interruption" which is used by the insurance industry. Limited downtime means restricting the loss of use to a portion of the facility whose services can be replaced relatively easily. For example, the services of a kitchen can be replaced temporarily by outside food vendors. On the other hand, inmates may not be able to be taken outside the facility if the services of a recreational hall are damaged or destroyed.

Which fire safety objective relates specifically to the needs of correctional facilities?

As the number one priority of correctional officials, security is an integral objective of the Simplified Fire Safety System although it is not an objective of other fire safety systems. However, the impact of security on the other objectives — and on the fire safety system as a whole — is significant. Fire safety must be maintained without jeopardizing the loss of inmates through escape, suicide, murder, or related security problems.

What special problems must be considered in designing means of egress from inmate housing areas?

17

17. Use this question as a means of generating class response.

During a fire, inmates need to be evacuated to a secure area or defended in place. Clearly, most aspects of fire protection in correctional facilities must take into consideration problems related to security.

GOALS

Now let's consider how the fire safety objectives of this system are achieved. The Simplified Fire Safety System for Correctional Facilities has five major goals*: ignition control; fuel control; occupant protection; detection and suppression activities; and planning and training operations.

As the diagram indicates, the ways in which these five goals must interact is signified by an "and" gate — \oplus . The use of the "and" gate shows that for the fire safety objectives to be achieved, all goals must be successful. Each of the five goals becomes, in turn, the single goal for a number of events which are referred to as "methods." To keep the system and the diagram simple, neither "and" nor "or" gates are used to relate the methods to attain each goal. Because the fire protection needs of correctional facilities vary widely, it is assumed that each facility will, with possible assistance from a fire protection engineer, design and develop a fire safety system that specifically addresses the needs of that facility.

It must be emphasized that the different goals do not impact equally on the ultimate level of protection. This means that "trade-offs" must be made. For example, higher flame spread materials can be used for interior finish if automatic sprinklers are provided; or, the allowable floor area limit can be increased if fire resistive rather than protected, noncombustible construction is used. "Trade-offs" will be discussed in more detail in later chapters of this manual.

Let's discuss briefly each goal of the Simplified Fire Safety System for Correctional Facilities. Subsequent chapters will cover each goal in greater depth.

18. Have students suggest their idea of equivalent protection and give examples of trade-offs they may have had to make on the job. 18

Ignition Control

Ignition control is the concept of eliminating uncontrolled heat sources so that a fire cannot be ignited either accidentally or intentionally. The methods for achieving the goal of ignition control are: (1) control smoking materials; (2) control electrical ignition sources; and (3) use alternate grievance procedures.

What are the method events of ignition control (or prevent fire ignition) as indicated by the Fire Safety Concepts Tree?

*In the Fire Safety Concepts Tree, these goals are termed *goal events*.

The method events required for successful control of ignition in the system represented by the Concepts Tree are: *Control Heat-Energy Source(s)*, *Control Source-Fuel Interactions*, and *Control Fuel*. In a similar manner, other goals of the Simplified Fire Safety System (especially fuel control and detection and suppression activities) can be referred back to the original Fire Safety Concepts Tree.

Fuel control is the second goal of the Simplified Fire Safety System. Fuel control is the concept of controlling the type, arrangement, and burning characteristics of potential fuels. Three methods for achieving fuel control are: (1) control quantity of fuel, (2) control types of fuel, and (3) control fuel arrangement. Assuming that fires are going to be ignited one way or another, then fuel control becomes the first effective step in fire defense. Ignition control, however, should continue to be practiced.

Fuel Control

The third goal of the Simplified Fire Safety System is occupant protection. Occupant protection is the concept of providing life safety in the event of fire either by evacuation to a secure area or by defending in place. Methods for this goal include: provide reliable evacuation to a secure area and provide features for a "defend in place" occupancy. Evacuation (which understandably is equated with means of escape by corrections personnel) is the most controversial and difficult portion of the fire safety system because it impacts directly on the objective of security.

Occupant Protection

Detection and suppression activities is the fourth goal of the Simplified Fire Safety System. Detection and suppression activities is the concept of automatically or manually detecting the presence of a hostile fire, sounding an alarm, and then suppressing the fire. Methods for this goal are: provide early warning detection, provide reliable alarm system, provide reliable suppression.

Detection and Suppression Activities

The fifth and last goal of the Simplified Fire Safety System is training and planning operations: the concept of conducting training activities and planning emergency operating procedures. Methods include: provide staff education and training, provide inmate education, and plan emergency procedures. This phase of fire defense is extremely important because it may require little capital investment in equipment. Moreover, training and planning operations can help to maintain a high level of security during a fire, and to make a marginal fire safety system effective. When fire defenses are basically weak, training and planning operations can help reduce the impact of a potentially disastrous fire.

Training and Planning Operations

It should be obvious that there are no simple answers to the problem of fire safety in correctional facilities. As in any occupancy, the level of fire safety depends on the effectiveness of the

19. Since most of the information contained in this chapter is completely new to the students and uses unfamiliar concepts and jargon, summarize the material and allow time for any questions.

19 overall fire safety system. No one goal or method can, by itself, free a correctional facility from potential fires: many facets combine to determine the degree of fire safety.

Before moving on to the next chapter which discusses ignition control, the first goal of the Simplified Fire Safety System, let's review.

CHAPTER REVIEW

20 Follow the instructions specified for the Chapter Review of Chapter One.

Answer the following questions. Check your responses by referring back to the appropriate section in the chapter.

1. Define a system.

.....

2. List the three attributes of a system.

a.
 b.
 c.

3. The basic rationale for using a systems approach is:

- a. That the analysis is not subject to error.
- b. That a systems approach permits detailed investigation of a large number of elements on a broad scale.
- c. That a systems approach is based on the concept of a computer system.

4. Identify the parts of the basic system model in the appropriate boxes.

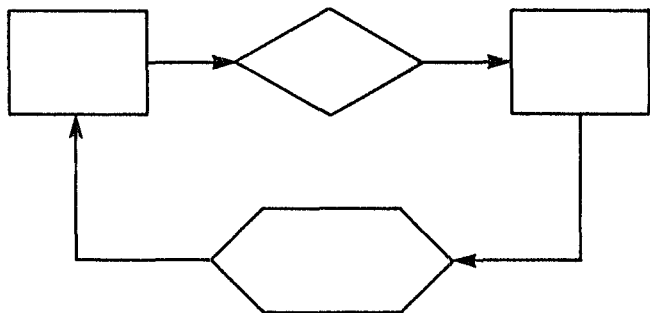

5. The systems approach provides three advantages for solving problems. They are:

a.
 b.
 c.

6. Briefly explain what the Fire Safety Concepts Tree represents and how it works.

.....

7. Which of the following are included in a total fire safety system?
- a. Components related to prevention and detection of fire but not suppression of fire.
 - b. Reduction of downtime.
 - c. Preservation of property.
 - d. Safeguarding of human life.
 - e. All components related to the prevention, detection, and suppression of fire.

8. The diagram below represents a portion of the Simplified Fire Safety System for Correctional Facilities. Identify the fire safety objectives and the goals of the system by

filling in the appropriate boxes. Also, indicate the interaction of the goals by putting in the symbol for the appropriate "and" or "or" gate.

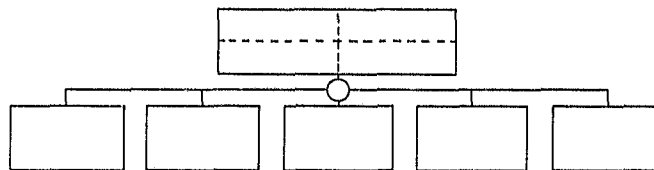

9. What impact does the security objective of the Simplified Fire Safety System have on the other objectives and on the system as a whole?

.....

.....

.....

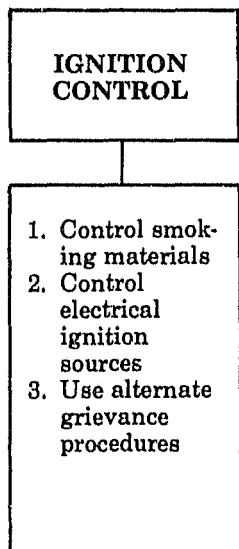

Chapter Three

THE FIRST GOAL: IGNITION CONTROL

OVERVIEW

This and the next four chapters take an in-depth look at each of the goals of the Simplified Fire Safety System for Correctional Facilities. This chapter, which examines the first goal, ignition control, includes case histories of failure, reliability, the methods for achieving ignition control, related fire protection technology, and information pertinent to inmates' rights.

Although each of the five goals will be studied individually, emphasis will be placed on their relationship to or interaction with other goals in order to demonstrate how the goals function together to reach and maintain a prescribed level of fire safety. In addition, the goals will be considered in terms of their relation to the objectives of the Simplified Fire Safety System.

1. The relationship and interaction among goals and their impact on the fire safety objectives of the Simplified Fire Safety System are brought up many times in this and the next four chapters. Because levels of fire safety vary widely among correctional facilities -- as do resources -- these points should be stressed whenever they are discussed in the text.

In this and the following chapters, you will use the information you have learned about the different goals of the fire safety system to complete a chart. The format of the chart will allow you to easily compare and contrast the goals of the system. Further, it will serve as a review of the information you have learned.

Before continuing, remove Table 3.1 and place it alongside this manual. As you can see, the chart is divided into five main sections: Goals, Case Histories, Methods, Available Technology, and Additional Factors. As each section is discussed in the text, fill in the appropriate information in the space allotted to it on the table.

After reading this chapter and completing the exercises as directed by the text, you will be able to do the following:

- Define the term "ignition control."
- Describe the relationship of ignition control to the rest of the Simplified Fire Safety System.
- List three methods for achieving ignition control.
- Identify the fire protection technology involved in ignition control and explain how its application contributes to fire safety.
- Describe how inmates' rights may affect implementation of methods used to achieve ignition control.

Before beginning this chapter, you may want to use the glossary to review any of the following terms with which you are not familiar.

combustible
incendiary
listed

Ignition control is the concept of eliminating uncontrolled heat sources so that a fire cannot be ignited either accidentally or intentionally.

Anytime there is a fire, by definition, ignition control has failed. Because the human error factor, whether deliberate or accidental, is inseparable from the concept of ignition control, this goal is probably the least effective of all fire defense measures. The large number of fires in correctional facilities attests to the low reliability of ignition control. However, this does not mean ignition control should be disregarded. Any success in reaching the goal of ignition control will improve the overall fire safety system.

From your experience in corrections, why would you expect ignition control to be the least effective fire defense measure?

Most fires in correctional facilities are set intentionally, that is, they are incendiary.

According to the study conducted by the National Fire Protection Association cited in Chapter One, what percentage of fires in correctional facilities are incendiary?

DEFINITION

RELIABILITY

2.

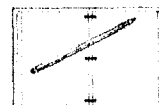

IGNITION CONTROL
Definition
Case Histories of Failures
Methods
Available Fire Protection
Technology
Additional Factors

Note: Instruct students to fill in their workbooks while you are discussing ignition control.

Table 3.1

REVIEWING COMPONENTS OF THE SIMPLIFIED FIRE SAFETY SYSTEM

COMPONENT	METHODS	CASE HISTORIES	AVAILABLE TECHNOLOGY	ADDITIONAL FACTORS
IGNITION CONTROL				
FUEL CONTROL				
OCCUPANT PROTECTION				
DETECTION AND SUPPRESSION ACTIVITIES				
PLANNING AND TRAINING OPERATIONS				

According to *A Study of Penal Institution Fires*, a study conducted by the National Fire Protection Association (see Chapter One), 87 percent of all fires in correctional facilities are incendiary in nature. The accuracy of this figure is supported by the eleven case histories of fires in correctional facilities, summarized in Table 1.1.

It is well established that if an inmate decides to set a fire in most situations he or she will find a way to do so. It is extremely difficult to prevent a determined inmate from setting a fire or from committing murder or suicide by fire. Many times, after extensive searches (including strip searches), inmates have managed to start fires.

Which fire safety objective does this problem affect most severely?

An inmate determined to use fire as a means for murdering, or committing suicide, or protesting what he or she considers to be an unsatisfactory condition, directly affects the objective of security. There is a significant effect on the other fire safety objectives if a fire is started. Due to the low reliability of ignition control, the other goals of the fire safety system, for example fuel control and occupant protection, play a more significant role in fulfilling the fire safety objectives.

There are three methods related to achieving the goal of ignition control: control smoking materials; control electrical ignition sources; and use alternate grievance procedures. The emphasis on which methods of control are implemented will vary with the type of facility in question: a facility housing convicted inmates or one housing pre-trial detainees. You may not find a grievance procedure in a jail that provides only overnight or pre-trial facilities.

**METHODS OF
CONTROL**

Although controlling ignition sources is the least reliable defense against fire, there is fire protection technology available that can help relieve the problem. The approach is generally one of open flame versus smoldering ignition sources.

**AVAILABLE
TECHNOLOGY**

Most fatal fires in *all* occupancies result from smoldering-type ignitions. These include ignitions from overheated electrical equipment as well as from cigarettes or smoking materials. In correctional facilities, however, 87 percent of all fires are incendiary, an indication of open flame ignition sources such as matches and cigarette lighters.

Which type of ignition source, smoldering or open flame, makes it easier to ignite combustible materials?

The thermal energy output of an open flame ignition source is substantially higher than a smoldering ignition source, thus making it easier to ignite commonly found combustibles such as polyurethane foam mattresses. With the technology that is available today, polyurethane mattresses can be constructed to resist smoldering ignition sources. However, the energy supplied by a paper match would still be sufficient to produce a fire in this type of mattress.

Although it is impossible to eliminate open flame sources of ignition, one means of controlling them is through use of quick extinguishing matches. Such matches are designed to burn with lower heat output and to self-extinguish after burning through one half of the match stick. Another alternative control is to install wall-type cigarette lighters, similar to automobile cigarette lighters, that can be permanently mounted.

Ground fault circuit interrupters (GFCI) can be used to control electrical ignition sources. Any leakage of current to ground, such as through an altered electric appliance, would trip the circuit breaker. Limiting the use of electrical appliances becomes a management function. Use of listed appliances and installation of proper distribution wiring, however, will help to reduce the chances of overheated electrical equipment and short circuits.

3 Because incendiary fires are so common in correctional facilities, the use of alternate grievance procedures is perhaps the most effective method for achieving ignition control. In some facilities there are means by which irate inmates can make their particular complaints or grievances known without resorting to setting fires. For example, organized grievance committees, direct communication lines between inmates and administrators (decision makers), and even petitions have effectively reduced the potential for incendiary fires. The latest standards from the American Correctional Association (ACA) state that any local, state, or county correctional facility will have an established grievance procedure.

The courts have also recognized the importance of the grievance mechanism within a facility. The trend of the courts is to insist that inmates exhaust internal mechanisms before coming to court. In situations lacking an organized procedure, the courts have recommended its establishment or utilization before permitting the hearing of corrections-related cases in court. The American Arbitration Association (AAA) has assisted some facilities in implementing these procedures.



3. Concept: All corrections personnel should be familiar with the operating principles of an effective grievance mechanism.

Activity:

(1) Instruct each group to give a brief description of the operation of the grievance mechanism for inmates of their facility. This description should include the organization of any committees, members, and communication lines for airing the grievances. If your facility does not yet have a grievance mechanism, groups can discuss how one should operate in their facility for maximum effectiveness.

(2) Instruct each group to arrive at a consensus of how they view the effectiveness of a grievance mechanism.

(3) Finally, ask each group to suggest how the grievance mechanism at their facility can be improved.

A correctional facility is usually considered a very closed system. During the past two decades, however, its practices have come under increasing scrutiny by the courts, as well as by the media. One underlying principle that has been upheld by a number of court cases is that an inmate retains his constitutionally inalienable rights even though his statutory rights remain outside the prison walls.*

What are some of an inmate's inalienable rights which you are required to safeguard on a daily basis?

How recent court decisions influence methods for achieving ignition control hinge on what any one inmate may construe as a violation of his right to life, health, and the pursuit of happiness, for example, restrictions on cigarette smoking or the number of electrical appliances in an inmate's cell. It must be left up to the seasoned judgment of individual superintendents to strike the delicate balance between necessary controls for safety and transgression of rights.

As most corrections administrators know, the routine of confinement provides a sense of security for inmates. Each inmate develops his own schedule and resents any change in routine. Thus, any actions taken to control ignition must be considered from the inmates' standpoint in order to prevent or reduce potential inmate unrest from developing. Changes must be introduced slowly and one at a time, with ample time provided for adjustments in the correctional routine. Each of these factors should be taken into consideration before making decisions or taking actions related to ignition control. This careful choice of ignition control methods in light of inmates' rights and inmate behavior may prevent problems, including debilitating lawsuits, from developing.

*E. Eugene Miller, *Jail Management*, Lexington, Massachusetts: D.C. Heath and Company, 1978, pp. 107-112.

ADDITIONAL FACTORS

4.



LEVEL I

Concept: Supervisory personnel should know what special problems in correctional facilities affect implementation of ignition control.

Activity:

(1) Before discussing this section, ask groups to brainstorm on what other considerations (besides those mentioned) can impact on ignition control. Do not let this discussion exceed more than two or three minutes. Instruct the groups to summarize and then report their suggestions.

(2) Write the group suggestions on a chalkboard and ask for comments from other groups.

(3) If the following points do not come up, bring them up for comment:

- inmates' rights (constitutional inalienable rights, personal comfort, need for recreation, preserving routines)
- inmate behavior
- legal aspects

FIRE SAFETY CHECKLIST



LEVEL II

5. Concept: Corrections officials should be aware of the problem areas in controlling sources of ignition in their facility.

Activity:

(1) Ask each group to conduct an inspection or survey of a particular cellblock, floor, or building (try to give each group an area with which they are likely to be familiar).

(2) Using the checklist (tailored to each individual facility), each group conducts a detailed inspection of the area for which it is responsible and writes a report of its findings.

(3) Each group's report should include areas where the problem of ignition control has been improved lately, the methods and technology used for the improvement, and specific suggestions for rectifying the problems its inspection has uncovered.

(4) Use overhead transparencies or a chalkboard so that other students can see and comment on the work their fellow workers have accomplished.

There are many elements that impact on the level of fire safety in correctional facilities. One way of organizing and reviewing some of these more critical elements is to use a checklist. With this chapter, we will begin developing a checklist which addresses methods affecting each goal of the fire safety system. Although the checklist will help you to review the level of fire safety in your facility, it will not help you to accurately evaluate the level of fire safety. Evaluation is the job of a fire protection engineer using the original fire safety system. Nor is the checklist meant to be used as a design tool. However, use of the checklist can provide a practical awareness of the more critical elements related to each goal of the Simplified Fire Safety System.

Ask yourself each of the following questions and check the appropriate answer.

- A "Yes" answer to the questions indicates that the probability of a disastrous fire occurring is reduced. It does not, however, mean that a fire will not occur. It is important that, once an acceptable level of fire safety is achieved, it is maintained at that desired level.
- A "No" or "Don't Know" answer to any of the following questions indicates an area that requires your attention, and which may ultimately affect the level of fire safety in your facility.

YES	NO	DON'T KNOW
-----	----	------------

1. Are special, supervised areas provided for smoking?
2. Is inmate access to smoking materials and matches controlled?
3. Is the use of extension cords prohibited?
4. Is there proper electrical distribution wiring?
5. Are all electrical appliances listed?
6. Are electrical appliances inspected regularly?

(5) This activity will be repeated for fuel control and occupant protection (Chapters Four and Five). Thus, you may want to wait until the completion of Chapter Five before actually assigning the activity. However, at least introduce the problem so that students can begin thinking about what will be expected of them. The inspections can be conducted during the normal routines of their jobs.

Before going on to the next goal of the Simplified Fire Safety System, let's review.

CHAPTER REVIEW 6

6. Follow the instructions specified for the Chapter Review of Chapter One.

1. What is ignition control?

2. The reliability of ignition control in correctional facilities is:
_____ a. low
_____ b. average
_____ c. high
3. Why is ignition control the least effective defense against fire?

4. List three methods for controlling ignition sources.
a. _____
b. _____
c. _____
5. Briefly describe the use of an alternate grievance mechanism as a potential method for controlling ignition.

6. Which type of ignition source has the greater thermal energy output?
_____ a. Smoldering ignition sources.
_____ b. Open flame ignition sources.
_____ c. Both smoldering ignition sources and open flame ignition sources have equal thermal energy outputs.
7. Technology is available so that polyurethane mattresses can be constructed to resist:
_____ a. Smoldering ignition sources.
_____ b. Open flame ignition sources.
_____ c. Both smoldering and open flame ignition sources.
8. Name one means for controlling open flame ignition sources and one means for controlling smoldering ignition sources.

Open flame ignition source:

Smoldering ignition source:

9. Which rights does an individual retain when incarcerated?
_____ a. statutory
_____ b. constitutional
_____ c. both
10. What factors must be taken into consideration before making decisions related to ignition control?

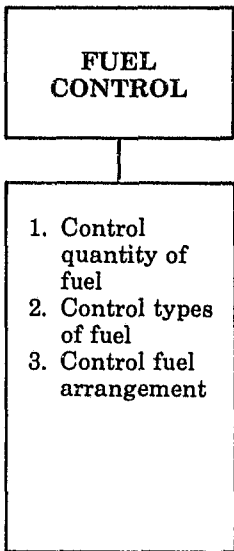

Chapter Four

THE SECOND GOAL: FUEL CONTROL

OVERVIEW

1. As a review of how fire is eliminated or controlled, briefly explain the tetrahedron of fire (see, for example, Chapter 4 of Section 2 of NFPA's *Fire Protection Handbook* 14th Edition). An alternative is the film, *Fire: Concepts and Behavior*, available for rental or purchase from the National Fire Protection Association. Your facility's fire brigade would probably benefit greatly from seeing this film.

When the problem of controlling fire is discussed, a number of elements must be considered: heat, fuel, oxygen, and an uninhibited chain reaction. When any one of these four elements is either controlled or removed, fire is also controlled or eliminated.

Chapter Three presented a number of means for controlling heat (the ignition source). Chapter Four deals with the control of potential fuels, a problem which has increased significantly with a rise in the amount and variety of synthetic materials produced for commercial use. Any attempts at controlling fuel must compare the convenience and availability of new products with the potential hazards that using them may create.

This chapter will provide sufficient background information regarding methods for achieving control, fuel types, case histories of failure, and up-to-date technology which will enable you to make decisions regarding fuel control at your facility. Remember to continue completing Table 3.1, in order to compare aspects of the system and provide yourself with a readily available summary.

After reading this chapter and completing the exercises as directed by the text, you will be able to do the following:

- Define fuel control.
- List three methods for achieving fuel control.
- Describe three ways in which the behavior of natural and synthetic fuels differs under fire conditions.

- Name one correctional facility fire in which fuel control failed for each of the following categories of fuels: building materials, interior finish, contents or furnishings.
- Identify a preferred fuel for optimum safety during a fire for each of the above categories.
- Explain any impact the inmates' rights issue may have on methods for achieving fuel control.

Before beginning this chapter you may want to review any of the following terms found in the glossary of this book with which you are not familiar.

building materials
 carboxyhemoglobin
 contents/furnishings
 fire-resistive
 flashover
 interior finish
 neoprene
 obscuration
 polyurethane
 styrene-butadiene foam rubber
 untenable

Fuel control is the concept of controlling the type, arrangement, and burning characteristics of potential fuels. If we assume (as we should) that fires are going to be ignited one way or another, then fuel control becomes the first effective step in the prevention of fire.

Does this mean that control of ignition sources should not be practiced?

No! It is necessary for every facility to practice ignition control. It is important to accept the reality that fires will be ignited. This means that the burden for defense against fire falls upon controlling the fuel, as well as implementing the remaining goals of the Simplified Fire Safety System.

As you will recall, fuel control was a major problem in many of the tragic incidents we discussed in Chapter One. These case histories can be categorized according to the area in which fuel control failed: contents or furnishings, building materials, or interior finish. For example, failure of fuel control for contents or

DEFINITION

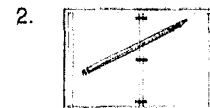

FUEL CONTROL
 Definition
 Case Histories of Failure
 Methods

COMPARISON OF FUEL TYPES
 Table 4.1
 (leave spaces for students to take notes)

furnishings contributed to the tragedies of the Seminole County Jail in Sanford, Florida; the Youth Correctional Center in Cranston, Rhode Island; and North Carolina State Prison at Marion, North Carolina.

Failure to control the fuel hazard presented by building materials took a heavy toll of life: 320 inmates in the Ohio State Prison Fire in Columbus, Ohio and 37 in the fire at Berrydale, Florida.

3. Although this question addresses only interior finish, asking students to recall fires in which any goal of the system failed serves as a good review.

3 *Name three fires where interior finish contributed significantly to property losses.*

Failure of fuel control for interior finish was evident in the fire at the City Detention Center in St. John, New Brunswick; the Maury County Jail in Columbia, Tennessee; and the Federal Correctional Institution in Danbury, Connecticut.

RELIABILITY

4. Generate class response by asking students what factors impact most heavily on the reliability of fuel control. As factors are given, write them on a chalkboard. Try to have students arrive at the three factors by reaching a consensus.

4 As has been illustrated, the failure to adequately control fuel has contributed significantly to death and destruction in correctional facilities. Three factors impact most heavily on the reliability of fuel control: the ease of control of some fuels compared to others, the impossibility of eliminating fuel, and the consideration of inmates' rights.

The goal of fuel control is to keep fuel quantity to a minimum, to provide spatial separation between combustibles and potential ignition sources, and to use materials that will burn slowly. A slow-burning fire gives people and fire protection equipment time to react to a fire incident. "Fast" fires have been the traditional killers in correctional facilities — "fast" rate of smoke production, "fast" flame spread, "fast" toxic products of combustion development. "Fast" fires can be caused by ordinary combustibles, such as low density fiberboard ceilings and thin plywood paneling. They can be produced by plastics such as polyurethane and by synthetic rubbers such as styrene-butadiene foam.

If it were possible to build everything of concrete, then the control of fuel would be virtually foolproof. Realistically, of course, the everyday necessities of life require that combustible materials be used for clothing, bedding, room furnishings, and inmates' personal property.



Mattresses and other furnishings, combined with an inmate's personal property, e.g., television, stereo, papers, books, and clothing, contribute significantly to the fuel load of living areas.

What particular combustible materials have made fuel control difficult?

Plastics have added a new dimension to the fuel control problem. Pound for pound, plastics have approximately twice the potential heat output of cellulosic material, such as wood and paper. Moreover, under fire conditions, some plastics may release this heat at a much higher rate, producing large amounts of smoke and other toxic products of combustion. These characteristics have a significant effect on whether a fire is fast-burning or slow-burning.

Finally, a significant problem in the reliability of fuel control concerns inmates' rights. Recreational articles, law books, and other reading materials contribute to a fuel load that is difficult to control.

The case histories related in Chapter One illustrated how fuel control failed in one of three areas: contents or furnishings, building materials, or interior finish. The methods of fuel control, then, reflect a concern with these three areas: control type of fuel; control arrangement of fuel; and control quantity of fuel.

What is the major problem in limiting inmates' personal property from the point of fuel control?

METHODS OF CONTROL

Table 4.1 COMPARISON OF FUEL TYPES			
FUEL TYPE	HEAT RELEASED	RATE OF HEAT RELEASED	TOXIC GASES PRODUCED
Natural (Cellulosic)	8,000 Btu's lb.	1x	CO, CO ₂
Synthetic (Petroleum-based)	16,000 Btu's lb.	5x to 100x	CO, CO ₂ HCl, HCN

Most of the inmates' items of personal property are ordinary combustibles (for example, clothes, papers, books) that contribute significantly to the fuel load of living areas. The issue of inmates' rights has made the limitation of inmates' personal property a considerable problem from the point of fuel control.

DESCRIPTION OF FUEL TYPES

5 LEVEL II: Emphasize hazards of synthetic fuels by showing slide-tape program *Firefighter and Plastics*, available from the National Fire Protection Association. The package was developed originally for fire fighters but the information is very much applicable to any environment containing plastics. In addition, many of the students probably are members of the facility's fire brigade and should be made aware of the severe hazards in a fire emergency involving synthetic fuels.

5 How the various fuel types behave under fire conditions is of primary importance in determining levels of fire protection. This factor serves to emphasize the contribution of the newer man-made or synthetic fuels to the problem of fuel control in correctional facilities. As the next section of this chapter will discuss, much of the available technology, especially in the areas of contents or furnishings and interior finish, is aimed directly at controlling synthetic fuels.

Basically, there are two types of fuels: natural or cellulosic and synthetic or petroleum-based. Cotton (such as cotton batting in mattresses), wood, and wool are examples of natural or cellulosic fuels.

What are some examples of synthetic or petroleum-based fuels found in correctional facilities?

6



COMPARISON OF FUEL TYPES
Table 4.1

Keep this discussion brief and not too technical for Level II students. Use Table 4.1 and the tables which follow it to emphasize the dangers of synthetic fuels.

6

Man-made petroleum-based fuels, such as polyurethane, styrene-butadiene foam rubber, and neoprene foam are used extensively in mattresses, other cell furnishings, and cell padding.

In discussing the fire behavior of these fuel types, we'll compare them in terms of heat released, rate of heat release, and toxic gases produced. Table 4.1 illustrates the basic differences in the fire behavior of natural and synthetic fuels.

Heat released refers to the amount of fuel contributed by a substance, usually measured in British thermal units (Btu's) per pound. Table 4.2 shows that the heat of combustion of most synthetic materials (e.g., polyurethane, vinyl chloride, etc.) is approximately 16,000 Btu's/lb. This is twice that of common cellulosic fuels such as wood! For cells and cell block areas high in concentration of synthetic combustibles (e.g., mattresses and other furnishings, foam padded walls, and plastic paneling), the potential hazard to inmates and fire fighters during fire conditions becomes severe. Unless designed for this type of fuel load, structural elements and fire protection systems can be rapidly overwhelmed by the intense fire.

As critical as the amount of heat release of various combustibles, equally critical is the rate of heat release. The higher the heat release rate of a material, the more rapid the fire growth. Table 4.2 compares the rate of heat release in Btu's per minute of identical weight samples of nylon upholstery materials padded with either urethane foam or cotton batting. This test was conducted at room temperature to simulate the ignition and smoldering stages of a fire. The maximum rate of heat release (after two

HEAT RELEASED

7 7.



LEVEL 1

RATE OF HEAT RELEASE COMPARISON Table 4.2

RATE OF HEAT RELEASE

Table 4.2

RATE OF HEAT RELEASE COMPARISON

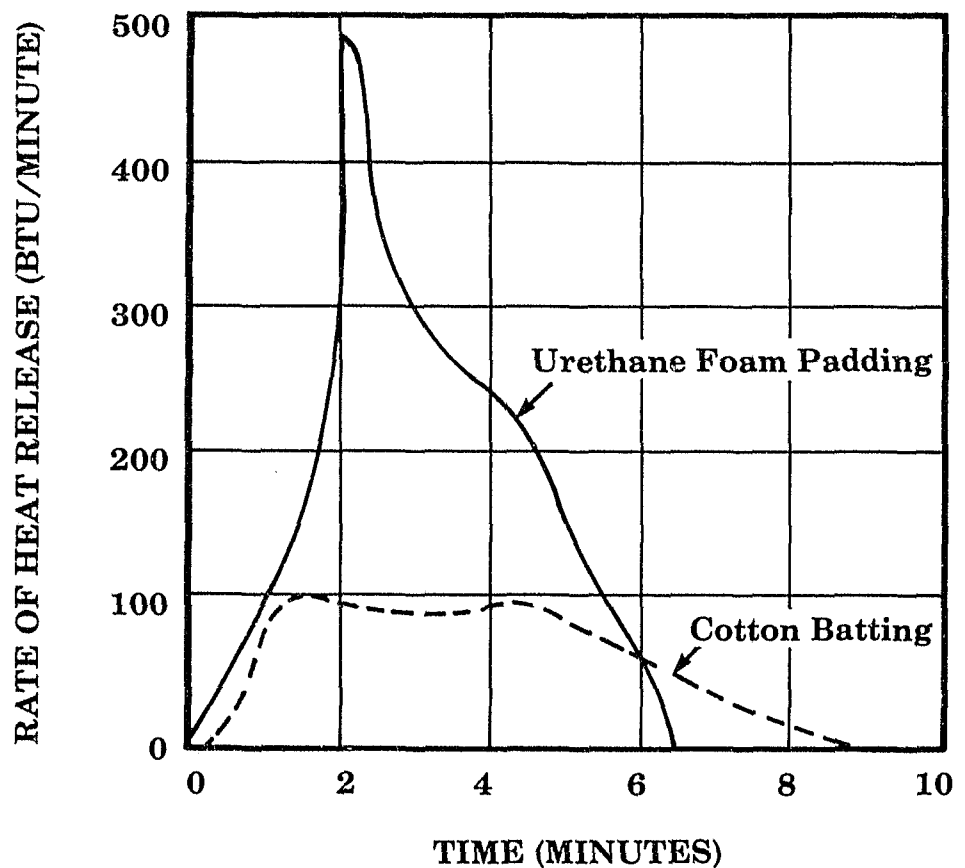

Table 4.3	
PHYSIOLOGICAL RESPONSE TO VARIOUS CONCENTRATIONS OF CO*	
Threshold limit value	Parts of CO per million parts of air 50
Concentration which can be inhaled for 1 hour without appreciable effect	400 to 500
Concentration causing unpleasant symptoms after 1 hour of exposure	1000 to 1200
Dangerous concentration for exposure of 1 hour	1500 to 2000
Concentrations that are fatal in exposures of less than 1 hour	4000 and above
<small>*K. Sumi and Y. Tsuchiya, "Toxic Gases and Vapors Produced at Fires," <i>Fire Service Information</i>, (Iowa State University Bulletin), Vol. 5, No. 1, (February 1974), p. 5.</small>	

minutes) of the urethane foam padding is five times that of the cotton batting padding. Clearly, mattresses using the same padding materials could have been substituted with no difference in comfort but with far greater fire resistance. Depending on the surface area, texture, and fire exposure conditions, the rate of heat release for furnishings of man-made materials can be up to 100 times that of furnishings made of natural materials.

TOXIC GASES PRODUCED

8. LEVEL II: Use this discussion to emphasize the need for all corrections officials to wear self-contained breathing apparatus (SCBA) during any fire emergency. The fact that plastics may not be involved in a fire does not eliminate the dangers of toxic gases -- especially carbon monoxide.

Finally, natural and synthetic materials are compared according to the primary toxic gases produced.* The danger of toxic gases is their adverse effect on body functions. As indicated by Table 4.2, both types of fuels produce carbon dioxide (CO₂) and carbon monoxide (CO). Both of these gases produce a significant hazard in many fires.

Carbon dioxide (CO₂), a normal by-product of respiration, is produced in most fires. Inhaling this colorless, odorless, and tasteless gas stimulates respiration. This, in turn, increases inhalation of oxygen as well as toxic gases produced by the fire. Breathing as little as five per cent concentrations of carbon dioxide can produce an intoxicating effect after 30 minutes. Higher concentrations can eventually result in unconsciousness.

*The term "primary" is used here because many other toxic gases, usually in smaller concentrations, are produced by fuels. For example, burning wood and wood products produce a wide range of aldehydes, sulfur dioxide (SO₂), acids, and other gases that may be severe irritants. Hydrogen sulfide (H₂S), a lethal gas in high concentration, is produced from burning leather and wood.

Briefly, carbon monoxide (CO) is produced as a result of incomplete combustion of materials containing carbon, whether in natural or synthetic substances. Carbon monoxide is colorless, odorless, tasteless, and present in large quantities at most fires. When inhaled, it causes asphyxiation by combining with hemoglobin (protein substances carried in red blood cells) in a reversible reaction to form carboxyhemoglobin. This action reduces the availability of oxygen for all cells of the body. In other words, the body is asphyxiated due to the blood's inability to carry oxygen. Table 4.3 shows how the body responds to various concentrations of carbon monoxide. As it indicates, exposure to high concentrations of carbon monoxide (4,000 parts of CO per million parts of air) can be fatal.

As mentioned previously, both natural and synthetic fuel types produce CO₂ and CO. Extremely dangerous is the hydrogen chloride (HCl) gas that is produced by many synthetic materials (for example, common plastics), including polyvinyl chloride (PVC) and vinylurethane, as well as common materials in upholstery for chairs and sofas. Table 4.4 shows the physiological



PHYSIOLOGICAL RESPONSE TO CO
Table 4.3



PHYSIOLOGICAL RESPONSE TO HCl
Table 4.4

Table 4.4	
PHYSIOLOGICAL RESPONSE TO VARIOUS CONCENTRATIONS OF HCl *	
	Parts of HCl per million parts of air
Threshold limit value	5
Maximum concentration allowable for short exposure (½ to 1 hour)	50
Dangerous for even short exposure	1000 to 2000
*K. Sumi and Y. Tsuchiya, p. 5.	

response to various concentrations of hydrogen chloride. Even low concentrations of HCl (5 parts of HCl per million parts of air) cause coughing, choking, and irritation of the eyes. Higher concentrations — even for a short period of time — can damage the upper respiratory tract and lead to death.

From what has been discussed, it is clear that the problem of fuel control is made even more acute by the use of many types of synthetic materials. Unfortunately, the answer is not simply to remove all mattresses, furnishings, and other items made of synthetics. However, limiting their use is a step in the right direction.

AVAILABLE TECHNOLOGY

11

Substantially more fire protection technology exists for fuel control than for ignition control.

11.

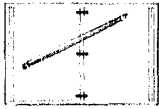

Why do you think this is so?

FUEL CONTROL

Available Fire Protection Technology

- Contents and furnishings
- Building materials
- Interior finish

Additional Factors

One reason there is more technology available for fuel control is that any technology related to ignition control is affected by a significant human factor: the determined inmate who wants to start a fire. Smoke development and the toxic products of combustion — the real killers in correctional facilities — are controllable. Moreover, the technology that goes into controlling the smoke and toxic products of combustion is not as easily subject to the whim or grievance of an inmate.

Another reason for substantial technology related to fuel control is simply that fuels, primarily the synthetics, are a major problem for all occupancies. The research that is going into smoke development and the toxic products of combustion applies to all structures — high-rise office buildings, homes, schools, as well as correctional facilities. However, it is still important to face the facts: neither ignition nor fuel can be controlled with 100 percent effectiveness.

CONTENTS OR FURNISHINGS

Contents or furnishings include mattresses and bedding materials. These are the fuel sources most readily available to inmates and thus most frequently involved in fires.

Many types of mattresses can be made to resist ignition by cigarettes, a smoldering type of ignition source. *Flammability Standard for Mattresses (FF4-72)* specifies a test for mattress resistance to cigarette ignition. (Note that this standard does not include how a mattress reacts when exposed to open flame ignition.)

What type of ignition source is responsible for the majority of fires in correctional facilities?

The majority of fires in correctional facilities are incendiary in nature, which indicates that open flame ignition sources (matches or lighters) are used. Although it is not realistic to expect a mattress to resist open flame ignition, mattresses that burn at a much

slower rate will permit more time until untenable conditions develop. This time allows people to react.

In September 1977, The National Bureau of Standards (NBS) completed a testing program aimed at the eventual development of fire performance standards for institutional mattresses. Report No. NBSIR-77-1290, *Combustion of Mattresses Exposed to Flaming Ignition Sources/Part I - Full Scale Tests and Hazard Analysis*, described the program in which ten mattresses were tested. Included were those with polyurethane, latex (styrene-butadiene foam rubbers), neoprene foam, and fire retardant treated cotton batting materials. The mattresses were evaluated on the basis of their capability to cause room flashover (all combustibles in the room igniting at once), and to make a room unsafe for people because of heat, smoke, and toxic gas concentration. The results of the test revealed that the test mattresses could be categorized into four distinct groups, in order of safety.*

12 12. The details of this study, briefly presented in this section, are probably of interest only to supervisory personnel.

- Group A Mattresses that did not exceed any of the tenability criteria for the duration of the 30-minute test. This group included two treated cotton batting mattresses.
- Group B Mattresses that only exceeded the smoke obscuration criterion. Two neoprene mattresses were in this category.
- Group C Mattresses that exceeded all tenability criteria but did not cause full room involvement. This group included three polyurethane foam core mattresses and one of mixed fiber construction. The best performing of the polyurethane mattresses was associated with a multiple life loss prison fire.
- Group D Mattresses that exceeded all criteria. Included were one styrene-butadiene latex foam core and one polyurethane foam core mattress. The latex mattress was associated with a multiple life loss, health care institution fire.

Which mattresses are shown by the NBS tests to be the best?

Due to the lack of a national standard for mattresses exposed to open flame ignition sources, many jurisdictions throughout the

*The study is available from: Center for Fire Research, National Bureau of Standards, Mail Building 225, Room A-07, Washington, DC 20234.

United States have developed their own evaluation method for prison mattresses. All have come to the same conclusion as the NBS: at the present time, the best mattresses for use in correctional facilities are those that have padding material of cotton treated with boric acid (Group A in the NBS study). The cotton treated with boric acid mattress was originally developed to pass *Flammability Standard for Mattresses (FF4-72)*.

What does FF4-72 specify?

FF4-72 specifies a test for a mattress' resistance to a smoldering ignition source. It was found that the mattresses of cotton treated with boric acid not only pass FF4-72, but also perform well when exposed to open flame ignition sources (provided the boric acid treatment is not limited to the surface layers of padding).

13. LEVEL II: Emphasize that mattresses made of fire-retardant construction will still burn. Thus, the fire problem is not eliminated, only controlled to a certain extent.

A note of caution about fuel control as it relates to mattress materials: because the mattresses in a correctional facility are of the fire retardant-treated cotton type does not mean that the fire problem is eliminated. Other fuels can be involved and cotton mattresses treated with boric acid will burn. However, they will burn at a much slower rate, resulting in a lower probability of a fatal fire involving bedding materials.

14. LEVEL II: Request students to come up with the disadvantages of cotton batting mattresses from their point of view as corrections personnel.

Although the cotton treated with boric acid mattresses seem to be the best materials available from the standpoint of fire protection, they do have several drawbacks. First, with continual use, cotton batting mattresses tend to lump up. This results in a significant deterioration in comfort. Second, this type of mattress cannot be sterilized as readily as ones made from synthetic

A building classified as fire-resistant, such as the one shown here, can withstand considerable exposure to fire without major damage.



materials. Third, cotton batting mattresses present a security problem because objects such as contraband and drugs can be more easily hidden deep within the material. Polyurethane foam mattresses, on the other hand, are a solid piece of material. This makes the hiding of objects within them more difficult and more easily detected.

Technology continues to search for the perfect mattress material. In the near future, a comfortable, low-cost, and fire-retardant synthetic mattress (able to be sterilized) will no doubt be produced. In fact, a mattress made of low-smoke neoprene shows significant promise.

Although mattresses and bedding materials are involved in most fatal fires in correctional facilities, other contents and furnishings also contribute to the problem of fuel control. Chairs, desks, and other furniture items are often composed of significant amounts of plastics and other synthetics. Where possible, it is best to furnish cells, recreational areas, cafeterias, libraries, and classrooms with items constructed of materials such as wood or metal, that have slower burning characteristics, and produce less smoke and toxic products.

Building construction and materials have come a long way from the hazards presented by wood frame construction. However, facilities which are of true heavy timber construction exhibit good structural integrity under fire conditions.

New correctional facilities should be built of fire-resistive construction.* Briefly, a building classified as being of fire-resistive construction has greater ability to resist structural damage from fire than any other building construction types. Critical structural members (for example, bearing walls or bearing portions of walls, columns, trusses, and girders) are required to be more resistant to fire damage than are secondary structural members (those supporting a floor or roof) which, in the event of failure, would not affect the overall structural stability of the building. These too, however, must have considerable fire resistance. As a result of such standards, a building classified as fire-resistive can withstand considerable exposure to fire without major damage.

In fire-resistive construction, only noncombustible (and, in some cases, limited combustible) structural materials are permitted. Materials such as steel, iron, brick, tile, concrete, slate, glass, and plaster are examples of traditionally noncombustible materials. Other materials, such as gypsum board, fall under the less restrictive definition of limited combustible. These materials, while not completely noncombustible, provide significant protection from fire.

*See NFPA 220, *Standard Types of Building Construction*, 1979, for detailed requirements on these types of construction.

BUILDING MATERIALS

15

15. Ask students if they know the type of construction used in their facility.



Although the materials in noncombustible/limited-combustible construction may not contribute fuel to the fire, the unprotected structural members may be damaged by heat.

Construction of noncombustible/limited-combustible materials does not qualify as fire-resistive construction, even when the walls, partitions, and structural members are of noncombustible or limited-combustible materials. In this type of construction, the materials may not contribute fuel to the fire; however, the unprotected structural members may be damaged by heat. Buildings of noncombustible/limited-combustible construction are more likely to be used for repair shops or industrial operations rather than for inmate housing.

The main feature of noncombustible/limited-combustible construction is its inability to spread fire. This, of course, assumes that the noncombustible or limited-combustible structural components are not nullified by use of combustible materials for other purposes. For example, materials such as asphalt and felt vapor barriers on metal roof decks can spread fire rapidly in an otherwise noncombustible building.

A third type of building that offers good resistance to fire is heavy timber or mill construction. In fact, under fire conditions heavy timber construction performs in a superior way to unprotected noncombustible structures. Due to the size and mass of planks and timbers, heavy timber construction provides a slow-burning building because the ratio of the exposed surfaces to the total volume of the combustible members is small. In addition, because heat conduction through the planks and timbers is relatively slow, failure under heat and flame attack is retarded. When the exposed wood surfaces char in a fire, the insulating effect of the charred wood further retards heat penetration.

Building materials are a good example of problems faced by older facilities. Many correctional facilities built of ordinary or, worse yet, wood frame construction are still in use. Although additions and renovations to these structures may be carried out with noncombustible or limited-combustible materials (for example, masonry, brick, gypsum board), the ability of the structure to withstand an interior fire and confine fire spread to one area is no better than the degree of protection of its combustible structural components.

One of the concepts of modern fire protection systems holds that the building itself should contribute to its own fire safety: a problem in these older ordinary and wood frame correctional facilities. What are some alternatives for providing adequate fire protection in these structures?

Where construction materials cannot be changed, it is necessary to place greater emphasis on other goals of the system. For older facilities, the alternatives for fulfilling fire safety objectives are clear: limitation of combustible contents, installation of sprinklers, an effective fire brigade or municipal fire department, and emergency planning. In addition, inadequate exit systems must be redesigned and effective locking systems installed.

Such alternatives for fire protection clearly indicate the role of trade-offs (or equivalent protection) in assuring that the Simplified Fire Safety System fulfills its objectives. You should recall that a vital aspect of the system is the interaction among goals. Each goal affects all other goals. With trade-offs, this interaction means that a predetermined combination of methods will provide the desired level of fire safety.

Interior finish is generally considered to consist of those materials or combination of materials that form the exposed interior surface of wall, ceiling, and floors. Combustible interior finishes, for example, fiberboard, foam plastic, thin paneling, and untreated plywood, have contributed significantly to multiple-death fires.

16

16.



The following group discussion has greater relevance to older facilities, but officials of newer facilities should be interested, especially because it illustrates the role of equivalent protection. Concept: It is important to realize that adequate fire protection can be provided for older structures.

Activity:

(1) Describe an older facility (real or fictitious) that does not have adequate fire protection.

(2) Have each group list alternatives for providing adequate fire protection.

(3) As each list is reported, write it on a chalkboard. Judge each item according to its feasibility (especially monetary).

(4) Point out to students that such alternatives illustrate the concept of trade-offs (or equivalent protection) which will become clearer as the course progresses.

INTERIOR FINISH

Why could the problems related to interior finish be more critical in correctional facilities?

17. Ask students to list the principal fire hazard characteristics of interior finishes. 17

In correctional facilities the security factor increases the potential for combustible interior finish contributing to the death of inmates. Although interior finishes are not usually the first items ignited, a developing fire can easily involve the interior finish, thereby contributing extensively to the spread of fire.

The characteristics of interior finishes are among the principal elements which determine the fire hazard of a building. Most relevant to fire problems include the ability of interior finish materials to (1) spread fire, (2) contribute fuel to the fire, and (3) develop smoke and noxious gases when burning. Thus, materials which exhibit high rates of flame spread, contribute substantial quantities of fuel to the fire, or produce hazardous concentrations of smoke or noxious gases are undesirable.

Interior finish plays an important role in the occurrence of flashover. Flashover is usually defined as the sudden and dramatic simultaneous ignition of most combustible materials in a room or area. It occurs when room temperatures near the ceiling rapidly rise to between 800 to 1,200 °F. The time between the ignition of fire in a room (or cell) and flashover is critical to the safe evacuation of room occupants and to effective rescue and suppression operations. An interior finish that absorbs heat readily and is not combustible, such as concrete, would increase the time to flashover. If the finish material is combustible, it will also serve as a fuel source for the fire.

Once a room fire reaches the stage of full involvement or flashover and openings to adjoining spaces allow escape of heat, smoke, and combustion gases, combustible interior finish of any kind or quantity becomes a significant factor in the spread of fire to other areas. Because of this fact and the wide variety of interior finishes that are available, interior finishes are classified according to their flame spread and smoke development. One method by which classifications are determined is the Steiner Tunnel Test. This test has been adopted by the National Fire Protection Association (NFPA 255, *Method of Test of Surface Burning Characteristics of Building Materials*, 1972), by the American Society for Testing and Materials (ANSI/ASTM E-84-792a, *Standard Method of Test for Surface Burning Characteristics of Building Materials*), and by Underwriters Laboratories Inc. (UL 723, *List for Surface Burning Characteristics of Building Materials*, 1977). The test rates, on a relative scale, the flame

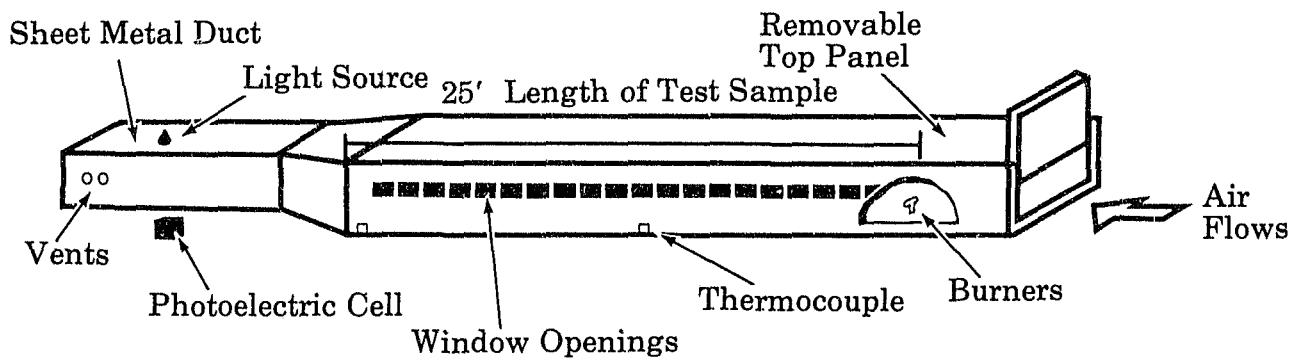

Figure 4.1 Steiner Tunnel Test Apparatus

spread across the surface and the obscuration (not toxicity) of the smoke developed from interior finishes.

Briefly described, the test places a 20-inch wide by 25-foot long test sample on the underside of a removable top panel of a tunnel, as shown in Figure 4.1. One end of the sample is ignited by gas burners. The surface burning characteristics are then observed through side window openings. The test is designed to simulate a fire exposure of about 1,400 °F in the area of the flames. Flame spread rate (that is, the time for flames to travel down the length of the tunnel or to cease or recede) is compared both to asbestos cement board which is rated at 0 and to select grade red oak rated at 100 for the same test conditions. Asbestos cement board and red oak are also used as reference points for the "fuel contributed" and "smoke developed" ratings determined by the tunnel test. These test numbers are relative to the characteristics of red oak and cement asbestos board only. Table 4.5 lists the flame spread ratings for various interior finish materials.

As Table 4.5 indicates, there is a wide range of flame spread ratings among interior finish materials. Generally, the higher the numerical rating, the greater the flammability hazard. In order to accommodate these variations, most building codes group interior finish materials into classes. Specifically, the classification set up in NFPA 101, *Life Safety Code*, is based on the following:

CLASSIFICATION	FLAME SPREAD RANGE	SMOKE DEVELOPED RANGE
A	0 - 25	0 - 450
B	26 - 75	0 - 450
C	76 - 200	0 - 450
D	201 - 500	0 - 450
E	over 500	0 - 450

Flame spread requirements for interior finish materials are based on both the type of occupancy and the location within a

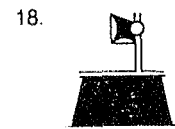

18. STEINER TUNNEL TEST
Figure 4.1
FLAME SPREAD RATINGS
Table 4.5

given occupancy. Although a high flame spread rating might be allowed in an isolated room, a low flame spread rating would be required for an exit access in the same building. In the case of a correctional facility, the interior finish requirements are even more strict. For purposes of the *Life Safety Code*, correctional facilities are a complex of structures with each serving a definite and usually different function. For example, a recreational room or dining hall is classified as a place of assembly. Cells and cell blocks are classified as residential, similar to hotels. (However, the 1981 edition of the *Life Safety Code* will have specific requirements for correctional occupancies.) According to the *Life Safety Code*, interior finish materials that are to be used in both exits and access to ex-

Table 4.5

FLAME SPREAD OF SOME BUILDING MATERIALS*

Material	Flame Spread
<i>Ceilings</i>	
Glass-fiber sound-absorbing blankets	15 to 30
Mineral-fiber sound-absorbing panels	10 to 25
Shredded wood fiberboard (treated)	20 to 25
Sprayed cellulose fibers (treated)	20
<i>Walls</i>	
Aluminum (with baked enamel finish on one side)	5 to 10
Asbestos cement board	0
Brick or concrete block	0
Cork	175
Gypsum board (with paper surface on both sides)	10 to 25
Northern Pine (treated)	20
Southern Pine (untreated)	130 to 190
Plywood paneling (untreated)	75 to 275
Plywood paneling (treated)	10 to 25
Red Oak (untreated)	100
Red Oak (treated)	35 to 50
<i>Floors</i>	
Carpeting	10 to 600
Concrete	0
Linoleum	190 to 300
Vinyl asbestos tile	10 to 50

*For a comprehensive list of flame spread and smoke developed, see the current edition of *Building Materials Directory* published by Underwriters Laboratories, Inc.

its for places of assembly must carry a classification of A. For these same locations in a hotel, the *Life Safety Code* permits interior finish materials with a B rating. In some occupancies, the addition of automatic fire suppression allows interior finish materials of a higher class (for example, B rather than A) to be used.

According to NFPA 101, Life Safety Code, which materials would be permitted as interior finish in the exit of a cell block? Which would be permitted in the exit access of the dining room of a correctional facility? Refer to Table 4.5.

As mentioned previously, the *Life Safety Code* classifies a cell block as a hotel and a dining room as a place of assembly. Where the *Life Safety Code* specifies that an interior finish material with a rating of A must be used, the choice of materials is limited. However, if an interior finish material with a rating of B is permitted, then a material with either an A or a B rating can be used.

Society's views on incarceration have changed dramatically during the last few years. The previous chapter documented how recent court decisions dealing with the issue of inmates' rights have influenced the methods of achieving ignition control. But nowhere are these changes felt more than in the area of fuel control. The significant changes have come in three areas: (1) living quarters, (2) personal comforts, and (3) recreation and education. Inmates' rights in each of these areas have a direct impact on fuel control.

That inmates are entitled to a humane and habitable environment is without question. Such an environment, however, is too often achieved at the expense of fuel control. Interior finishes, such as paneling (wood or plastic), cover harsh prison walls but create an environment that is easily vulnerable to the ravages of fire.

Besides heat, smoke, and noxious gases, what additional danger do combustible interior finishes present during fire conditions?

19.



LEVEL I

Concept: Supervisory personnel should be aware of how changes in inmates' rights impact on the fuel control problem.

Activity:

(1) Explain to students that recent court decisions and the inmates' rights issue have impacted heavily on the problem of fuel control in correctional facilities.

(2) Request groups to compile a comprehensive list of the new fuels that have been developed and added to correctional facilities because of changes in the three areas: living quarters, personal comforts, and recreation and education. As an alternative, you can assign each group one area. In addition, each group's report should include: (a) the most feasible methods of meeting the fuel control problem for each area, and (b) any control measure their facilities have taken or plan to take in the future.

(3) Use the chalkboard or overhead projector to summarize reports.

19

ADDITIONAL FACTORS

LIVING QUARTERS

As you will recall, the nature of the interior finish has a significant effect on the occurrence of flashover; and where the interior finish is combustible, the material also contributes fuel to the fire.

There are, however, some acceptable compromises that provide improved fire characteristics (including increased time to flashover) and an environment that is habitable. For example, the Federal Correctional Institution in Danbury allows wall finishes that are painted masonry or gypsum board surfaces. Other interior finishes that offer a livable environment and still have relatively good fire characteristics are a treated paneling (Class A) and painted steel.

PERSONAL COMFORT

Some measures used to create personal comfort can be deadly in a prison fire. It has already been documented that mattresses and bedding materials are frequently involved in fatal fires. It is the extensive use of polyurethane, styrene-butadiene foam rubbers, and other synthetics that has contributed most heavily to the multiple deaths from fires in correctional facilities. It is difficult for any inmate to understand that one of the few comforts of incarceration might have to be relinquished for some improbable fire.

RECREATION AND EDUCATION

Inmates' rights in the areas of recreation and education have added substantially to the problem of fuel control in correctional facilities. Most notably, the increased use of books, especially law books, has contributed significantly to the fuel load in cells, as well as in prison libraries. Rather than limit the use of books, it might be more practical to increase the amount of fire protection in those locations where large numbers of books are used. Another method may be to require that books be stored in metal cabinets or lockers so that they would not be exposed to fire.

Inmates' rights concerning living quarters, personal comfort, and recreation and education are going to continue to impact greatly on the problem of fuel control. These rights are important; yet, safety from fire cannot be sacrificed either. Some of the methods for fuel control that have been discussed in this chapter are significant steps toward solving this problem.

CHECKLIST

20

20.



LEVEL II

Concept: Corrections personnel should be aware of the problem areas in fuel control.

Activity:

(1) Follow the instructions for the group discussion assigned for the checklist in Chapter Three.

(2) For this checklist you may want to assign each group a different area (e.g., one group covers contents and furnishings, another group reports on building materials, and a third group covers interior finish).

Here is a checklist for fuel control similar to the one in Chapter Three for ignition control. The checklist is divided into the three main areas that have been discussed in this chapter: contents or furnishings, building materials, and interior finish. It is important that you study it closely and then use the format to outline a more extensive checklist specifically suited to your facility.

A "NO" or "DON'T KNOW" answer to any of the following questions indicates an area that requires your attention.

YES	NO	DON'T KNOW
-----	----	---------------

Contents or Furnishings

- | | | | |
|-------|-------|-------|--|
| | | | 1. Are the furnishings in use noncombustible? |
| | | | 2. Are mattresses constructed, in whole or in part, of foamed plastics (polyurethane) or foamed rubber (latex or styrene-butadiene foam rubber)? |
| | | | 3. Are furnishings padded with foamed plastics or foamed rubber? |
| | | | 4. Are foamed plastic or foamed rubber padding on walls, ceilings, or floor (padded cell)? |
| | | | 5. If any of the above furnishings are used, do you know the fire characteristics of the materials? |
| | | | 6. Has any action been taken to alleviate the hazard created by materials which have been shown to have poor fire performance? |

Building Materials

- | | | | |
|-------|-------|-------|--|
| | | | 1. Is the building of fire-resistive construction? |
| | | | 2. Is the building of noncombustible/limited-combustible construction? |
| | | | 3. Is the building of heavy timber or "mill" construction? |
| | | | 4. Is the building of ordinary or wood frame construction? |

Interior Finish

- | | | | |
|-------|-------|-------|--|
| | | | 1. Are untreated plywood or wood, plastic, or laminated paneling used as interior finish in your facility? |
| | | | 2. Are foamed plastics or combustible fiberboard used as interior finish in your facility? |
| | | | 3. If any of the above materials are in use, do you know what the fire characteristics of these materials are (that is, flame spread and smoke developed ratings)? |
| | | | 4. Has any action been taken to alleviate the hazard created by materials which have been shown to have poor fire performance? |

Before going on to occupant protection, the third goal of the Simplified Fire Safety System for Correctional Facilities, let's review.

11. Even though a building of ordinary construction is renovated with materials that are noncombustible, what factor limits the ability of the structure to withstand an interior fire or to confine the spread of fire to one area?

12. In what ways do interior finishes contribute most to fire problems?

- _____ a. They contribute to the spread of fire.
- _____ b. They contribute fuel to the fire.
- _____ c. They are usually the first item ignited.
- _____ d. They contribute to the development of smoke and noxious gases when burning.

13. What is flashover?

14. Why is the time between the ignition of fire in a room and flashover critical?

15. How is the Steiner Tunnel Test used in fire prevention?

16. In which location would an interior finish with a high flame spread be most hazardous?

- _____ a. in an isolated room
- _____ b. in an exit or exit access

17. Briefly discuss how inmates' rights have impacted on the fuel control problem in each of the following areas:

Living Quarters

Personal Comfort

Recreation and Education

OCCUPANT PROTECTION

1. Provide reliable evacuation to secure area
2. Provide features for "defend in place" occupancy

Chapter Five

THE THIRD GOAL: OCCUPANT PROTECTION

OVERVIEW

Concepts involved in fire protection reflect the responsibility for safeguarding people. Whether that protection means helping people exit a burning building or protecting them while they remain inside is the substance of occupant protection, the third goal of the Simplified Fire Safety System. Even when ignition control and fuel control fail, the occupants of a building can still be defended against fire if this goal of the system is effective.

Chapter Five will introduce the concepts of a defend-in-place occupancy and means of egress. The chapter will also discuss methods for control, case histories of failure, and related fire protection technology in order to help improve occupant protection and thus the total fire safety system at your facility.

After reading this chapter and completing the exercises as directed by the text, you will be able to do the following:

- Define occupant protection.
- List two methods for achieving occupant protection.
- Name three correctional facility fires in which occupant protection failed.
- Identify the fire protection technology involved in occupant protection and explain how its application contributes to fire safety.
- Explain any impact the inmates' rights issue may have on methods for achieving occupant protection.

1. Have a copy of NFPA 101, *Life Safety Code*, available for student reference while teaching this chapter. Some familiarity with the concepts presented in this chapter can be gained by reading NFPA 101.

Before beginning this chapter you may want to use the glossary to review any of the following terms with which you are not familiar.

- compartmentation
- defend-in-place occupancy
- fire door
- fire partition
- fire resistance
- fire wall
- fire window
- hazard of occupancy
- HVAC system
- life safety
- means of egress

Occupant protection is the concept of providing life safety in the event of fire either by evacuation to a secure area or by defending in place. It is important to remember that fire safety must be provided while maintaining security. What this means in a corrections environment is that inmates must be evacuated from their cells to another secure area of refuge or reliably defended from fire in their cells. No other options exist.

In relation to occupant protection, there are two general types of correctional facilities. The first is the larger institution that has an inner area, such as a courtyard, ball field, or other secure area of refuge. In this type of facility it is possible to evacuate inmates from a fire area to this secure area of refuge so that they will not be adversely affected by the fire and its products of combustion, and still maintain security.

An area such as the ball field shown below may serve as a secure area of refuge for inmates in the event of evacuation.

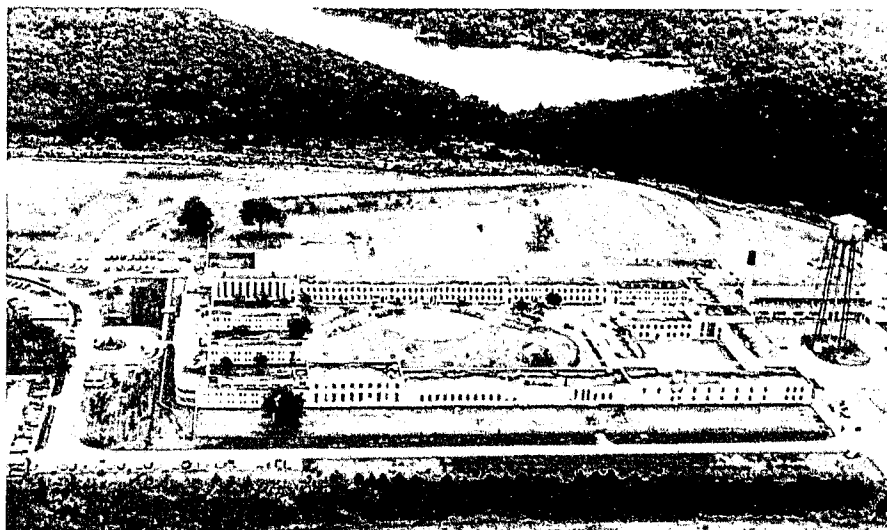

DEFINITION



2. OCCUPANT PROTECTION
Definition
Case Histories of Failures
Methods
Definition of Means of Egress
Separate and distinct parts:
1.
2.
3.

The other type of correctional facility is the smaller institution that has no separate area of refuge. In order to maintain the necessary level of security, inmates must be defended from the fire in place as there is no place to move inmates. This type of facility is referred to as a defend-in-place occupancy.

Besides a correctional facility, can you think of another defend-in-place occupancy?

A common defend-in-place occupancy is a nonambulatory patient hospital or hospital wing. In these hospitals, as in correctional facilities, the technology exists to defend occupants in place, so that only the room of fire origin needs to be evacuated.

RELIABILITY

Failure to provide occupant protection in correctional facilities has had tragic consequences. At the Youth Correctional Center in Cranston, Rhode Island, two young boys lost their lives; at the Maury County Jail in Columbia, Tennessee, the toll was a more substantial forty-two dead; and at the Saint John City Detention Center, St. John, New Brunswick, twenty-one inmates succumbed to the intense heat and smoke. In these three fires alone, sixty-five people paid for the failure of occupant protection with their lives.

What were the specific ways in which occupant protection failed for each of these fires?

Cranston, Rhode Island: _____

Columbia, Tennessee: _____

St. John, New Brunswick: _____

As you will recall from the discussion in Chapter One, in both the Cranston, Rhode Island and Columbia, Tennessee incidents, prob-

lems with keys delayed the release of inmates. In both of these tragedies and the St. John fire, the rapid buildup of smoke combined with inadequate ventilation contributed to the large loss of life.

What these tragedies clearly point out is the absolute necessity to provide reliable occupant protection. Occupant protection impacts directly on life safety. Even if the other four components of the fire safety system fail, successful protection of occupants can still save lives. In addition to the three fires mentioned above, consider some of the other fatal fires discussed in Chapter One. In nearly each one, some failure of occupant protection was a major contributor to the senseless deaths that resulted. There are no alternatives if there is a fire; therefore, occupant protection must succeed.

Besides life safety, what other objectives of the fire safety system are affected by occupant protection?

Occupant protection has a significant impact on all the objectives of the fire safety system. As this chapter will show, even if a facility protects its inmates by evacuation to a secure area, the objective of security need not be sacrificed. Nor will a facility jeopardize the objectives of limited downtime or property protection if it chooses to defend inmates in place.

The methods of control for occupant protection are: to provide reliable means of egress for evacuation to secure areas or to provide features for a defend-in-place occupancy.

In the field of corrections, providing reliable means of egress in order to evacuate inmates is a controversial and difficult issue. Why?

For some individuals in corrections, means of egress and evacuation are equated with escape. While this assumption is not valid, means of egress does impact directly on security.

METHODS OF CONTROL

- 3 3. Elicit student response related to this question.

AVAILABLE TECHNOLOGY

4. To supplement your discussion of technology related to occupant protection, consult Appendix B of this book for the proposed chapters of the 1981 Life Safety Code.

- 4 Today, the technology exists to defend inmates in place from fire or to evacuate them to a secure area of refuge. In some cases, it may be easier to achieve the high level of reliability with the defend-in-place option than with the evacuation method.

The primary objective of the defend-in-place occupancy is life safety. If this is met, what other objectives will probably be accomplished?

If inmates are successfully defended in place, then property protection and limited downtime objectives, along with the security requirements, will probably be accomplished.

From the standpoint of providing a reliable means of egress for evacuation, two means of egress are critical in any occupancy during a fire emergency. Not only do means of egress provide paths for inmates to move to a secure area of refuge or to the outside, but they also provide means of access for the fire department so that fire fighting efforts can take place. If the problems can be detected, and inmates notified and guided into movement to a safe place faster than the fire can develop intolerable conditions, then the objective of life safety will be achieved.

Exits alone, however, are no guarantee of life safety from fire. Such situations also require the additional protection afforded by emergency lighting systems, fire-resistive compartmentation, smoke control, and, of course, reliable locking systems. A discussion of the available technology in each of these areas follows, beginning with means of egress.

MEANS OF EGRESS

Most people assume that a means of egress means simply exit facilities. However, a means of egress should be designed and regarded as an integral part of the fire safety system which provides reasonable safety to life from fire. In other words, exit design decisions should be based upon an evaluation of a building's total fire defense system together with an analysis of population characteristics and the specific hazard of the occupancy.

In designing a means of egress for a correctional facility, what important factor must be considered?

In designing a means of egress for a correctional facility, an important consideration is security. Many of the factors that affect the

Figure 5.1 Components of a Means of Egress

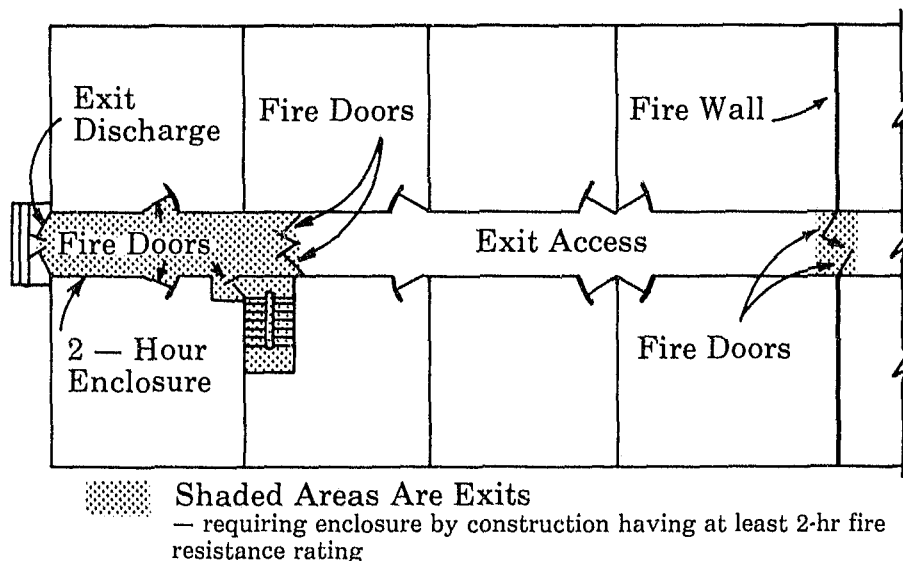

design of a means of egress, for example, human factors, movement of people, and hazard of occupancy, will not be discussed in this manual, but are set forth in NFPA 101, *Life Safety Code*.

According to the *Life Safety Code*, means of egress is a continuous and unobstructed way of travel from any point in a building or structure to a public way. There are four general criteria for an effective means of egress: (1) a continuous path to a safe area for the duration of the fire; (2) adequate capacity; (3) routes safe from intrusion by fire during evacuation; and (4) availability at all times. The *Life Safety Code* provides requirements for designing means of egress that meet all four criteria. The *Code* also defines three separate and distinct parts for a means of egress: (1) exit access; (2) the exit; and (3) exit discharge.

As Figure 5.1 shows, an exit access is that portion of a means of egress which leads to the entrance of an exit. The access to an exit may be a corridor, an aisle, a balcony, or a gallery. The length of the access establishes the travel distance to an exit.

What is the importance of the length of travel distance to an exit?

The length of travel distance to an exit is significant since excessive time might unduly expose an occupant to a fire and its hazardous products of combustion. The average distance recommended by the *Life Safety Code* is 100 feet, but the length can vary with the occupancy, the potential fire hazard, and the physical ability and alertness of the occupants.

5

5. Instruct students to underline key words in the definition.

6

Exit Access

6.



MEANS OF EGRESS
Figure 5.3

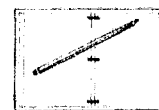

AVAILABLE TECHNOLOGY
Means of Egress
Figure 5.3
(without labels)

Egress System — description and requirements

- Exit access
- Exit
- Exit discharge
- Emergency lighting

Note: Instruct students to identify the parts of a means of egress while each part is being discussed.

A fundamental principle of exit access is the provision for a free and unobstructed way to exits. The access should not be circuitous nor require travel through several rooms, long corridors, or many stairs. In most cases travel distance can be increased — up to 50 percent — if the building is sprinklered. If the exit access passes through a room that can be locked or through an area containing a fire hazard more severe than is typical of the occupancy (for example, a storage room or trash room), the principles of exit access are violated. In addition, dead-end corridors are not good practice. Since there is only one access to an exit from a dead end, a fire in a dead end between an exit and an occupant can keep the occupant from reaching the exit. Also, dead ends can become smoke filled, trapping occupants who are traveling toward an exit. Designers have some flexibility in exit placement, however, since the *Life Safety Code* usually permits dead ends of twenty to fifty feet, depending on the occupancy.

Exit

An exit is that portion of a means of egress which is separated from the building area by walls, floors, doors, or other construction, thus providing a protected path to the exterior of the building. It may comprise vertical and horizontal means of travel such as doorways, stairways, escalators, ramps, corridors, passageways, and exterior stairs. Elevators are not accepted as exits.

The Life Safety Code specifies that exits must be remote from each other. Why would you expect this to be a requirement?

Exits should be remote from each other so that they cannot readily be blocked by a single fire.

Exit Discharge

Exit discharge is that area between the termination of the exit and the exterior of the building at ground level. Ideally, all exits in a building should discharge directly to the outside of the building. For correctional facilities, however, security dictates discharge to a fenced yard, court, or compound area. Sufficient area must be provided to handle the expected occupant load far enough away from the building so that the inmates will not be exposed to fire in the building.

Emergency Lighting

An important part of the design of an egress system is emergency lighting. The *Life Safety Code* requires emergency lighting for the means of egress based upon occupancy criteria

which are applicable to most correctional facilities. Well-designed and reliable emergency lighting uses a power source independent from the normal building service and automatically provides the necessary illumination if the normal service is interrupted. Several ways to provide power for emergency lighting are: two sources of commercial power; standby power from electric generators; central bank of storage batteries; or battery units.

Whether a facility evacuates its inmates to a secure area or defends them in place, compartmentation is an important aspect of occupant protection. Compartmentation means using building construction to confine a fire and the products of combustion to the area of origin. The walls, ceiling, and floors must be fire resisting and openings must be protected with self-closing doors. The fire protection given to these elements depends on the degree of hazard presented by the occupancy (fuel loading), the type of building construction (for example, fire resistive or ordinary), and the function served (for example, a load-bearing or non-load-bearing wall). In correctional facilities, as in any occupancy, the purpose of compartmentation is to limit the number of people exposed to a fire.

Spaces are created within a building by constructing interior partitions. In order to protect certain areas more completely than would be possible with ordinary partitions, fire walls and fire partitions are constructed. When properly constructed, these barriers provide effective protection against the spread of fire.

A fire wall is a fire resistant barrier that normally extends through the roof to prevent the spread of fire from one side to the other. Fire walls must be structurally stable so they will remain standing and effectively stop the passage of heat and flames even when fire has engulfed the building on one side of the wall. To withstand heat expansion effects, fire walls are commonly made thicker than normal fire resistance ratings require. In industrial applications, self-supporting fire walls have traditionally been constructed of thick brickwork. Fire walls normally require four-hour fire resistance ratings, depending on the anticipated fire severity. In addition to brick, typical materials for fire walls include reinforced concrete, concrete block, and gypsum plaster.

A fire partition is an interior wall which serves to restrict the spread of fire, but does not qualify as a fire wall. Usually, a fire partition is used to subdivide a floor or an area. It extends from one floor to the underside of the floor above. Fire partitions are constructed of noncombustible or limited combustible materials and are attached to and supported by structural members having fire resistance at least equal to that of the partition. The fire resistance ratings of fire partitions are normally one to two hours.

7 COMPARTMENTATION

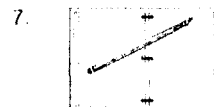

AVAILABLE TECHNOLOGY:
Compartmentation

- Fire walls
- Fire partitions
- Fire doors and windows
- Floors and ceilings

As with any of the discussions which involve hardware or building materials, you can obtain samples from supply houses or hardware stores, particularly those that service commercial or industrial occupancies.

Fire Walls and Fire Partitions

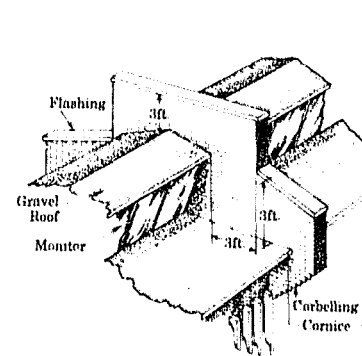

Fig. 5.2 A fire wall prevents the spread of fire from one area to another.



Fire Wall
Figure 5.4

Fire Doors and Windows

Compartmentation includes the protection of openings in fire-rated walls and partitions. Fire doors are the most widely used and accepted means for the protection of both vertical and horizontal openings. There are several types of construction for fire doors. Among these are composite doors, hollow-metal doors, metal-clad doors, and sheet-metal doors. Doors such as wood hollow-core and wood panel have no fire resistance rating and cannot be considered as fire doors.

For purposes of identifying the various types of openings commonly encountered, NFPA 80, *Installation of Fire Doors and Windows*, classifies openings as A, B, C, D, or E. The openings are classed in accordance with the character and location of the wall in which they are situated. For example, doors at openings in a fire wall must retain practically the same degree of effectiveness as the wall. It is important to note that this classification applies to the opening and not the fire door.

Floors and Ceilings

Floors play a critical role in the vertical confinement of fire. Floor construction must be able to maintain its structural integrity and stability at elevated temperatures. There are two common types of fire resistant floor constructions. One is a concrete slab of varying thickness and design. The second is a composite assembly consisting of a floor slab and ceiling membrane.

Solid concrete slabs, either cast-in-place or precast concrete, offer inherent fire resistance. The degree of fire resistance depends on the thickness of the slab, type of concrete, and means of support. Any type of ceiling can be placed below this type of floor slab.

The composite floor-ceiling assembly consists of a noncombustible membrane ceiling with a floor construction above. The floor construction generally consists of exposed steel framing with a thin floor slab. In the event of a fire, the ceiling acts as a barrier to protect the floor assembly above. It is critical that the ceiling membrane be constructed in accordance with approved design and that its integrity be maintained at all times.

This discussion of compartmentation has included only the basic building elements involved in confining the spread of fire. Depending on the occupancy, other areas that might be considered are concealed spaces, corridors and stairs, and escalators.

SMOKE CONTROL

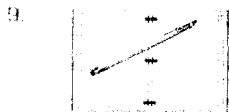

AVAILABLE TECHNOLOGY

Smoke Control

- Reasons for controlling smoke
- Relation to fuel control
- Techniques

- 1.
- 2.
- 3.

9. Smoke control is another important application of fire protection technology for occupant protection.

Why is the control of smoke a serious problem in correctional facilities?

In correctional facilities, as in other occupancies, smoke and the gaseous products of combustion are the number one killers in fires. Also, dense smoke severely hampers rescue and fire fighting efforts.

Solving the problem of smoke begins with controlling the materials used in a building, those used in construction, and those comprising the contents.

Relation to Fuel Control

What are some of the items that contribute to the smoke problem in correctional facilities?

The use of synthetics in mattresses, furnishings, personal belongings, and finishes contributes significantly to the problem of smoke and toxic gases in correctional facility fires. A partial solution is to follow the requirements for using materials with low smoke developed ratings as specified in the *Life Safety Code*, for example, using treated cotton mattresses. Besides reducing fire intensity, this solution also reduces smoke development.

In addition to controlling the type of fuel, the control of smoke generally involves techniques of dilution, venting, or confinement. Dilution means reducing the concentration of smoke by blowing massive quantities of uncontaminated air into a building. However, because smoke production is so great in some instances, dilution alone is not a satisfactory solution for protecting occupants from smoke. For example, one square foot of flexible polyvinylchloride (PVC) will produce approximately as much smoke as 500 square feet of oak.

Techniques for Controlling Smoke

A second technique for controlling smoke and the products of combustion is venting. In one- and two-story buildings, some relief from smoke can be achieved by the judicious use and placement of automatic-opening vents. Generally, several smaller vents are better than a single large vent, as it is more likely that one vent will be located over the fire.

A third method of smoke control involves confinement, that is, providing a barrier to contain smoke in the area of fire origin. This is accomplished by one of two ways. One way involves a physical barrier such as a wall with self-closing doors and dampers which restrict smoke movement. However, no physical barrier will prevent smoke movement totally. The second method is the use of a pressure differential between the fire area and the rest of the building. By pressurizing the protected area and exhausting the

fire area, a pressure differential will be developed which will retard or prohibit smoke movement out of the fire area. A combination of physical barriers with pressurization is considered the most practical method of smoke control. This type of smoke control is addressed in NFPA 90A, *Air Conditioning and Ventilating Systems*, and NFPA 101, *Life Safety Code*. The building HVAC (heating, ventilating, and air conditioning) system can be designed to provide this pressurization.

LOCKING SYSTEMS

10

10.

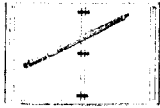

AVAILABLE TECHNOLOGY

Locking Systems

Types of Doors NFPA 101, *Life Safety Code* Requirements

1. Swinging Doors
2. Sliding Doors
 - a. Functions of Sliding Doors
 - b.
 - c.
 - d.

Locking systems comprise an area of occupant protection peculiar to correctional facilities. As discussed in Chapter One, problems with locks played a major role in many of the correctional fire tragedies. A reliable locking system is necessary for any correctional facility; yet, this same locking system must function in emergency situations, whether a facility evacuates its inmates or defends them in place.

The technology of locking systems has advanced significantly since the days when a single large skeleton key locked a dungeon door. Indeed, there are almost as many different types of locking systems as there are correctional facilities. The purpose of the locking systems, however, is to lock and unlock doors and in some cases to move sliding doors to the open position. In the case of swinging doors, it is important that the door swing away from the inmate in the cell so it can be opened readily when unlocked. Doors that swing in can be blocked intentionally or unintentionally by relatively small objects. In an emergency situation it is almost impossible to open a swinging cell door against the body of an unconscious person.

All sliding doors have four functions which apply to an emergency life safety situation in a detention institution. The functions are: (1) locking, (2) unlocking, (3) door movement open, and (4) door movement closed. Where sliding doors are used, *door unlocking is not door opening*, and door locking is not door closing. From a life safety point of view, doors may be unlocked but not opened. From a security point of view, doors may be closed and still not locked. In many electric indication panels, a red light is often used to indicate "unlock" and it is assumed for security purposes that the door is also open. This may be a proper assumption for security but not for life safety. It is quite possible for a sliding door to be unlocked but not open to permit egress from a threatened area. The 1981 edition of the *Life Safety Code* recognizes this difference in the locking and opening modes of sliding doors. The *Code* requires that all sliding doors have a provision for unlocking from a remote point away from the door. It also requires that manual mechanical means be provided at a remote point to move the doors to the open position as well as to unlock them in the event of a loss of power in electrically operated systems.

Locking systems and locking and operating systems can be generally classified into mechanical, manual, electro-manual, electro-mechanical, and electric pneumatic. The systems for swinging doors are designed differently from the systems for sliding doors. For example, a particular mechanical linkage may be advantageous for either security or life safety when applied to one type of door, but less advantageous when applied to another. For this reason, Table 5.1 applies to swinging doors and Table 5.2 applies to sliding doors. Each type of locking system is listed according to its operational characteristics, major security advantages, and potential for safety or failure during fire situations.

All locking systems are a combination of mechanical linkages coupled with some operating power. The term "mechanical" indicates a mechanism that requires only the turning of a key or the throwing of a bolt to make it perform. The term "manual" indicates the use of manpower to pull a lever, turn a wheel, and so on. "Electro-manual" implies that the system receives its power from either an electrical power source or manpower. "Electro-mechanical" indicates that electric motors are the sole source of power, with a mechanical release provided as described above in "mechanical." "Electric-pneumatic" includes pneumatic power for door movement and electric power for door unlocking or electric operation of relays which allow for pneumatic unlocking.

Since the use of either swinging doors or sliding doors determines the function provided in the various combinations of locking and operating systems, Tables 5.1 and 5.2 are designed to compare the security effectiveness of a particular locking and operating system to its effectiveness during a fire situation. No attempt has been made to list all the security features of any locking or door operating system. Rather, the emphasis is on life safety. In order to achieve the objectives of the Simplified Fire Safety System, the same locking system or locking and operating system must be able to keep inmates contained under normal conditions while enabling their unobstructed removal during emergency conditions. The use of the system for handling the inmate population under normal conditions will occur with great regularity every day. The conditions for utilizing the system for removal under emergency conditions may occur only once in a number of years. The emergency operation needs to be learned and recalled easily regardless of the system used.

Protection for occupants is most effective when it is included in the total design concept of a new or renovated facility. There is no reason why even the oldest facility should not be able to provide adequate protection for its inmates. The technology is available; the exact degree of occupant protection must be weighed in terms of the other goals of the Simplified Fire Safety System and the fire safety objectives.

(2) When groups report, use a problem-solution approach. Have one group state what they consider to be a problem factor. Ask a different group for a proposed solution that will alleviate or eliminate the problem.

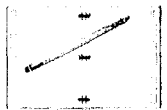
- 11 
- 11 AVAILABLE TECHNOLOGY
Locking Systems
Classifications of locking and operating systems.
- 1.
 - 2.
 - 3.
 - 4.
- 12 Comparison of Systems
Manual, Mechanical, Electric
- Operation
 - Security Advantages
 - Potential Failure in Fire Situations

Operational Features

12. For Level I students, these two tables should be discussed in detail, especially the categories pertaining to fire and life safety emergencies. Your presentation should include transparencies (the tables can be presented in sections) and/or copies of tables for students. The tables can be used as a basis for students completing an inventory of the locking systems within the facility.

13.  LEVEL II

Concept: Corrections officials should understand the locking system at their facility.

Activity: (1) Instruct each group to briefly describe the locking system at their facility in terms of: type of system and operation, locking/unlocking, security advantages, and potential failure during fire emergency. The description should be specific, preferably in chart form.

(2) As each point is mentioned, write it on the chalkboard.

(3) After each group reports, have students comment on what can be done in a fire emergency to overcome the limitations of the locking system.

14.  LEVEL I

13 Concept: Supervisory personnel should be aware of all factors that may impact on occupant protection.

Activity: (1) Have groups consider some additional factors that may impact on occupant protection with regard to recent court decisions and the inmates' rights issue. Mention that some of the points may have been brought up in the discussions in Chapters Three and Four, but here you are looking for those factors involving occupant protection. Stress that any points brought up should not compromise inmates' rights or security.

**Table 5.1
SWINGING DOORS**

TYPE OF SYSTEM	KEYS	LOCKING/ UNLOCKING	SECURITY FEATURES	REMOTE INDICATION	REMOTE OPERATION	MECHANICAL OVERRIDE		
MECHANICAL								
Padlocks	1 Per Lock	By Hand Key in Lock	Simple	None	None	None		
Deadbolts	None	By Hand at Door	Bolt is positive -- difficult to breach	None	None	None		
Commercial Lockset	Individual or Multiple	By Hand	Picking difficult	Locking electric only None with power off	None	Key at door only		
Detention Locks	Large Individual or Multiple Keyed	By Hand	Picking difficult Leverage in key size for over coming bolt friction or warpage	Locking electric only None with power off	None	Key at door only		
ELECTRIC								
Remote Electro-Mechanical Unlocking	Key Lock in Door	Unlocked Indication Deadlock Indication	Evaluation assumes electric devices are in the fail lock condition. If locks are built to fail unlock, when power is lost security level is greatly reduced during short temporary power outages before auxiliary power source is activated.	Unlocked indication Deadlock indication	Electrically allows physical retraction of bolt at door	At door only		
Remote Electro-Mechanical Bolt Return	Key Release Jamb	Bolt Position Deadlock Indication	Evaluation assumes electric devices are in the fail lock condition. If locks are built to fail unlock, when power is lost security level is greatly reduced during short temporary power outages before auxiliary power source is activated.	Bolt position deadlock indication	Electrically bolt retracted at door, some offer partial door opening	At door only		
Remote Manual & Electro-Mechanical Bolt Retraction	Key Lock in Jamb or Door	Deadlock Bolt Position	Evaluation assumes electric devices are in the fail lock condition. If locks are built to fail unlock, when power is lost security level is greatly reduced during short temporary power outages before auxiliary power source is activated.	Deadlock position operate position. Positions all indicated electrically or manually	Electric or manual bolt retract, some offer partial opening of door	At door and at emergency release console		
TYPE OF SYSTEM	IN FIRE AND LIFE SAFETY EMERGENCY							
	ACCESSIBILITY FOR EMERGENCY EVACUATION		POSSIBILITY OF HUMAN ERROR		ADVANTAGES	LIMITATIONS		
	POWER ON	POWER OFF	POWER ON	POWER OFF				
	(Good) (Fair) - Scale - (Fair) (Poor)	(Good) (Minimal) (Poor)	(Low) (Medium) (High)					
MECHANICAL								
Padlocks	NA	Poor	NA	High	None	Loss or breakage of keys requires locking & unlocking at location of emergency		
Deadbolts	NA	Poor	NA	High	Bolt is self contained	Bolt may bind under pressure Operates only at scene of emergency		
Commercial Lockset	NA	Minimal	NA	Medium High	Keying doors to one key	Breakage of key or binding of cylinder Keyhole stuffed		
Detention Locks	NA	Minimal	NA	Medium	Will not bind under door pressure Leverage of key aids release	Key unlocking must occur repeatedly Keyhole stuffed		
ELECTRIC								
Remote Electro-Mechanical Unlocking	Fair	Poor	High	Very High*	Power On Power Off	Release from any location Unlocked at door with single key	Power Off Repeated key unlocking of all doors required. Security greatly reduced if unlocking occurs when power is lost. Low voltage solenoid may fail to retract bolt if door is under pressure when power is activated.	
Remote Electro-Mechanical Bolt Return	Good	Poor	Medium	High**	Power On Power Off	Release can be accomplished from any location Lock & deadbolt released by key at door	Power On Power Off	Low voltage solenoid may fail to retract bolt if door is under pressure when power is activated Requires unlocking of each door by key at door
Remote Manual & Electro-Mechanical Bolt Retraction	Good	Good	Medium	Low***	Power On Power Off	Release can be accomplished from any location Door lock, deadlock and/or electric deadlock can be released by manual mechanical means from a remote point	Power Off	Manual indication of locking or unlocking, or door release. Not as easy to follow as Electric indication

Credit: Southern Steel Company, San Antonio, Texas

- * Key Release In Door
- ** Key Release In Jamb
- *** Remote Manual Release At Emergency Release Console

**Table 5.2
SLIDING DOORS**

TYPE OF SYSTEM	KEYS	LOCKING/ UNLOCKING	DOOR MOVEMENT	SECURITY FEATURES	REMOTE INDICATION		REMOTE CONTROL			
					LOCKING/ UNLOCKING	OPEN/ CLOSE	MECHANICAL RELEASE	MECHANICAL DOOR MVMT.	ELECTRICAL RELEASE	ELECTRICAL DOOR MVMT.
MECHANICAL										
Padlocks	1 Per Lock	By Hand Key in Lock	By Hand at Door	Simple	None	None	None	None	None	None
Detention Locks	Large Individual or Multiple Keyed	By Hand	By Hand at Door	Picking difficult — leverage in key size for overcoming bolt friction or warpage	Electric only None with power off	None	None	None	None	None
MANUAL										
Lever in Control Cabinet	Keyless	Selected at Control Cabinet	By Lever from Control Cabinet	Operated from safe location	None	Door selector shows position	By lever at control cabinet	From control cabinet at end of cell line — door can be opened and closed from remote point without electric power	None	None
Wheel in Control Cabinet	Keyless	Selected at Control Cabinet	Turning Wheel at Control Cabinet	Guard not exposed to prisoners, requires little effort to operate many doors	Mechanical Indication	Mechanical Indication	From usual control cabinet	From control cabinet at end of cell line — door can be opened and closed without electric power	None	None
ELECTRIC										
Electro Manual	Keyless	One Motor Per Cell Line	One Motor per cell line performs locking and door movement functions	Electric unlocking & movement of doors or manual unlocking & movement of doors in power failure from same control panel	Constant mechanical indication with power on or off	Constant mechanical indication with power off	Mechanical unlocking in event of power failure	Doors can be moved open or closed by remote manual means in event of power failure	Electrical remote control for normal operation	Doors move open electrically by motor in control cabinet
Electro Mechanical	Keyless	Solenoids or Fractional H.P. Motors at each Door-Lever Release W/ Power Off	One motor per each door unlocks and moves door - power off, door movement is by hand only at each door	Electric controls can be located at any point judged safest	Electric only No indication with power off	Electric only No indication with power off	Doors released from alternate emergency point other than usual control cabinet	Doors can only be unlocked from remote point in event of power failure - doors cannot be moved open from remote point by mechanical means in power failure	From regular control cabinet	Switch in control cabinet activates motor in each door
Electric Pneumatic	Keyless	Solenoid Release of Air Lever Release in Event of Power Failure	Air driven by separate unit at each door. Lever release from control cabinet in event of power failure	Quiet, low maintenance, variable force applied to door in emergency	Electric only No indication with power off	Electric only No indication with power off	Lever at control cabinet	None from remote point	Pneumatic unit operated by solenoid	Pneumatic unit at each door activated by solenoid from switch in control cabinet
Electric Detention Locks	Large Individual Keys — Multiple Keys Keyed to One Key	Selected at Console	By hand at door	Unlocked from electric console or by key at door	Electric only No indication with power off	None	None	None	Yes	No
TYPE OF SYSTEM	ACCESSABILITY FOR EMERGENCY EVACUATION				IN FIRE AND LIFE SAFETY EMERGENCY					
	POWER ON		POWER OFF		POSSIBILITY OF HUMAN ERROR		ADVANTAGES		LIMITATIONS	
	(Good) (Fair) (Poor)	— Scale — (Good) (Fair) (Minimal) (Poor)			(Low) (Med) (High)					
MECHANICAL										
Padlocks	NA	Poor	NA	High			None	Loss or breakage of keys requires unlocking and operation at location of emergency		
Detention Locks	NA	Minimal	NA	Medium/High			Leverage of key aids release of bolt if binding occurs	Key unlocking must occur repeatedly Key hold stuffed		
MANUAL										
Lever in Control Cabinet	NA	Good	NA	Low			Release and move doors open without entering area	Mechanism may injure prisoner One jammed door could jam all		
Wheel in Control Cabinet	NA	Good	NA	Low			Release and move doors open without entering area	Jammed door must be released at door		
ELECTRIC										
Electro Manual	Good	Good	Low	Low			Doors can be moved to full open position from remote point electrically or by manual means in power outage. Electric controls can be located at safest point	Jammed door must be released at door		
Electro Mechanical	Good	Fair	Low	Low			Electric controls can be located at any point judged safest	Emergency power off release cabinets often distance from control cabinets & require different procedure to operate. Doors cannot be moved open from remote point by manual mechanical means if power off		
Electric Pneumatic	Good	Fair	Low	Low			Pneumatic power reliable and easily varied to provide additional power for opening in emergency	Doors released from control cabinet must be opened by hand at door. Doors cannot be moved open from remote point by manual mechanical means when power is out		
Electric Detention Locks	Fair	Minimal	Medium	Medium/High			Permit remote electric unlocking in emergencies	Low voltage solenoids and motors are not strong enough to resist binding of doors or intentional blocking		

Credit: Southern Steel Company, San Antonio, Texas

CHECKLIST 15

The checklist is continued here for occupant protection. It is important to remember that this is not all-inclusive but is an aid to reviewing.

15.



LEVEL II

Activity:

(1) Follow the instructions for the group discussion specified for the checklist in Chapter Three.

(2) For this checklist you may want to assign each group a different concept (e.g., one group covers means of egress, another group covers locking systems).

Concept: Corrections officials should be aware of the problem areas in occupant protection.

YES NO DON'T KNOW

General

- | | | | |
|-------|-------|-------|--|
| <hr/> | <hr/> | <hr/> | 1. Can occupants be either defended in place or reliably evacuated to a secure area of refuge? |
|-------|-------|-------|--|

Means of Egress (see NFPA 101, Life Safety Code)

- | | | | |
|-------|-------|-------|---|
| <hr/> | <hr/> | <hr/> | 1. Are there at least two remote paths of exit travel from each cellblock or area? |
| <hr/> | <hr/> | <hr/> | 2. Is travel distance to exits within the limits defined by the <i>Life Safety Code</i> ? |
| <hr/> | <hr/> | <hr/> | 3. Are proper exits provided? |
| <hr/> | <hr/> | <hr/> | 4. Is the capacity of exits adequate? |
| <hr/> | <hr/> | <hr/> | 5. Are the exitways continuously illuminated? |
| <hr/> | <hr/> | <hr/> | 6. Is emergency lighting provided? |
| <hr/> | <hr/> | <hr/> | 7. Are the exits and paths to them marked clearly? |
| <hr/> | <hr/> | <hr/> | 8. Are exit accesses kept clear and maintained in usable condition? |

Smoke Control

- | | | | |
|-------|-------|-------|---|
| <hr/> | <hr/> | <hr/> | 1. Are emergency vents, if provided, in working order? |
| <hr/> | <hr/> | <hr/> | 2. Is the HVAC system capable of exhausting some of the smoke or confining smoke to area of origin during a fire emergency? |

Locking Systems — Swinging Doors

- | | | | |
|-------|-------|-------|--|
| <hr/> | <hr/> | <hr/> | 1. Do all swinging doors on cells and multiple occupancy rooms swing away from occupant? |
| <hr/> | <hr/> | <hr/> | 2. Are reliable means provided to permit the release of inmates from locked areas? |
| <hr/> | <hr/> | <hr/> | 3. Is prompt release of inmates assured by adequate correctional personnel on duty continuously with keys available in case of loss or breakage during a fire emergency? |
| <hr/> | <hr/> | <hr/> | 4. Is more than one set of keys available in case of loss or breakage during a fire emergency? |
| <hr/> | <hr/> | <hr/> | 5. Can all inmates be removed from an area of refuge in less than three minutes? (See Appendix B examples.) |
| <hr/> | <hr/> | <hr/> | 6. Are only two keys required to release inmates and move them to an area of refuge? |

- _____ 7. Are electric powered locks equipped with manual mechanical release from remote point?
- _____ 8. Are solenoid operated bolts powerful enough (110 volts or greater) to retract bolt with pressure exerted on door due to intentional blockading or binding of door?
- _____ 9. Do cell door locks remain locked when power is interrupted?

Locking Systems — Sliding Doors

- _____ 1. Regardless of normal operating power (manual, electric, pneumatic, etc.), are all keyless sliding doors equipped to be *unlocked* by a manual mechanical means operated from a remote point?
- _____ 2. Regardless of normal operating power (manual, electric, pneumatic, etc.), are all keyless sliding doors equipped to be *moved to the open position* by a manual mechanical means operated from a remote point?
- _____ 3. In a power failure, is there any indication at the control console that doors are locked or unlocked?
- _____ 4. In a power failure, is there any indication at control console that doors are open or stopped in transit?
- _____ 5. Is the manual mechanical means for opening doors located in or near the normally used control point?
- _____ 6. Can an operator select or control sequence of doors being released?

16. Follow the instructions specified for the Chapter Review in Chapter One.

CHAPTER REVIEW 16

- 1. Define occupant protection.
 - _____
 - _____
 - _____
- 2. What are the two options for providing fire safety while maintaining security in correctional facilities?
 - a. _____
 - b. _____
- 3. Occupant protection impacts upon which of the following fire safety objectives?
 - _____ a. life safety
 - _____ b. security
 - _____ c. occupant protection
 - _____ d. limited downtime
- 4. Which of the following are methods of control for occupant protection?
 - _____ a. automatic extinguishment
 - _____ b. manual extinguishment
 - _____ c. evacuation to a secure area
 - _____ d. control type of fuel
 - _____ e. defend-in-place occupancy
- 5. What Code provides requirements for designing exit systems?
 - _____
- 6. In the following diagram, label the three separate and distinct parts of a means of egress.

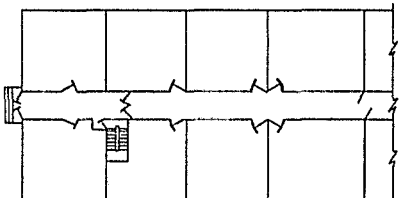

7. What effect upon travel distance can the addition of sprinklers make?

8. Why should exits be remote from each other?

9. Briefly, list the four criteria for an effective means of egress.

- a. _____
- b. _____
- c. _____
- d. _____

10. What is the chief requirement for the source of power of emergency lighting?

11. What are the principal building elements involved in compartmentation?

12. Differentiate between a fire wall and a fire partition.

13. Which statement is true?

- _____ a. NFPA 80, *Installation of Fire Doors and Windows*, classifies fire doors as A, B, C, D, or E.
- _____ b. NFPA 80, *Installation of Fire Doors and Windows*, classifies openings as A, B, C, D, or E.

14. What is the most widely used and accepted means for protecting both horizontal and vertical openings?

15. Match the reference to smoke control in Column A with its description in Column B.

A

- _____ a. dilution
- _____ b. exhaust
- _____ c. confinement

B

- 1. Controlling smoke through the use of vents and, in some buildings, the HVAC system.
- 2. Providing a barrier to the passage of smoke into certain areas; protect temporary refuge areas.
- 3. Reducing the concentration of smoke by infusing massive quantities of uncontaminated air into a building.

16. Name the four functions of sliding doors which apply to an emergency life safety situation in a corrections facility.

- a. _____
- b. _____
- c. _____
- d. _____

17. Name the five general classifications of locking systems and locking and operating systems.

- a. _____
- b. _____
- c. _____
- d. _____
- e. _____

**DETECTION
AND
SUPPRESSION
ACTIVITIES**

1. Provide early warning detection
2. Provide reliable alarm system
3. Provide reliable suppression
4. Provide manual suppression

Chapter Six

THE FOURTH GOAL: DETECTION AND SUPPRESSION ACTIVITIES

To this point, only issues which will prevent ignition or lessen the hazardous conditions produced by a fire have been discussed. Detection and suppression activities, however, deal directly with the fire itself — that is, sensing the fire's presence, alerting occupants, and then inhibiting its growth and ensuring its extinction — in short, keeping losses to a minimum.

Chapter Six is basically an in-depth discussion of the available technology — the substance of detection and suppression. Following the format for the Simplified Fire Safety System, reliability, case histories of failure, and methods for achieving control will also be presented.

After reading this chapter and completing the exercises as directed by the text, you will be able to do the following:

- Define detection and suppression activities.
- List three methods for achieving detection and suppression activities.
- Identify any special security problems involved in the implementation of these methods for control.
- Compare the reliability of manual and automatic systems.
- Name three correctional facility fires in which detection and suppression activities failed.
- Identify the fire protection technology involved in detection and suppression activities and explain how its application contributes to fire safety.
- Explain any impact the inmates' rights issue may have on methods for achieving detection and suppression activities.

1 OVERVIEW

1. Your presentation of this chapter should be altered somewhat, especially for Level II personnel. Specifically, the lecture format should be accompanied by a formal hands-on training program. Your local fire officials can provide you with a great deal of assistance with such a program. Level II personnel, at the very least, must have hands-on training in the proper use of portable fire extinguishers, standpipe and hose systems (if Class II or III), and self-contained breathing apparatus.

In addition, there are excellent informational and training films and slide-tape packages that can (and should) be used in your presentation. Some, e.g., the 16-mm film, *Automatic Sprinklers: The Myth and the Magic*, are more appropriate for supervisory personnel. Others can be presented to both Level I and II personnel, e.g., *The A, B, C's, and D's of Portable Fire Extinguishers*, a 16-mm film. Information for obtaining these and other programs will be discussed when they are referenced in this chapter.

Visuals, such as slides, are an asset to any educational and training program. For this chapter they take on added significance, since we are talking about the operation and use of equipment and devices which officials may actually have to use and/or install. Equipment used in detection and suppression lends itself easily to slides. Overheads may come in handy where proper installation is a consideration. Also, many

visuals are already available, either from private sources or a number of educational publishing companies. At the very least, your presentation should include slides — and better yet, exhibits — of the following: different types of detectors, alarm systems, portable extinguishers, self-contained breathing apparatus, and various types of sprinklers heads

Before beginning this chapter, you may want to review any of the following terms with which you are not familiar.

- ambient temperature
- energized equipment
- eutectic metal
- Halon
- ionize
- margin of safety
- photoelectric
- protective signaling system
- self-contained breathing apparatus
- standpipe
- trade-off
- untenable

DEFINITION

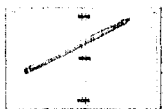

2.

DETECTION AND SUPPRESSION ACTIVITIES
 Definition
 Case Histories of Failure
 Methods
 Margin of Safety
 Figure 6.1

Detection and suppression activities involve the concept of automatically or manually detecting the presence of a hostile fire, sounding an alarm, and then extinguishing the fire. This definition emphasizes the division of detection and suppression activities into three distinct and separate stages, each of which can be performed automatically or manually (see Table 6.1).

RELIABILITY

The reliability of detection and suppression is tied very closely to whether systems are manual, automatic, or both. A fire protection system can involve a combination of systems, such as

Table 6.1		
<i>STAGES OF DETECTION AND SUPPRESSION</i>		
STAGE	MANUAL	AUTOMATIC
Detection	Inmate or guard detects fire	Sprinklers detect fire
Alarm	Guard verbally transmits information to other guards	Activates alarm water flow switch
Suppression	Guards use extinguishers to suppress fire	Sprinklers begin extinguishment immediately

automatic detection (smoke detectors) with manual suppression (fire brigade personnel using a standpipe hose). Although this type of protection was available at the time of the St. John City Detention Center fire and the system functioned as designed, twenty-one inmates died.

Which goal of the Simplified Fire Safety System was not implemented at the St. John City Detention Center, thus helping to contribute to these deaths?

Although the major reason for this gruesome tragedy was the lack of fuel control, the effects of fuel control problems were exaggerated by the inclusion of manual suppression. The response time for manual suppression is not as immediate as for an automatic sprinkler system. Furthermore, the action of sprinklers allows for increased safety during evacuation by reducing the amount of heat and making it easier to contain the fire.

Automatic systems provide the greatest degree of reliability because the effectiveness of detection and suppression depends on the rate of fire growth and development, and the time from ignition to suppression. For example, if a fuel characteristically produces a fast fire, the extinguishing agent must be applied rapidly in order to effect control and subsequent suppression.

With what type of system is extinguishment likely to begin immediately upon detection?

With an automatic sprinkler system, the extinguishment phase begins almost simultaneously with detection and alarm. This kind of response is difficult to achieve with manual suppression, even when automatic detection is part of the system.

Let's take a closer look at fire development to see how manual and automatic systems compare in five phases of detection and suppression: detection, alarm, response, application of agent, and control.

MARGIN OF SAFETY IN FIRE

3



3 MARGIN OF SAFETY
Figure 6.1

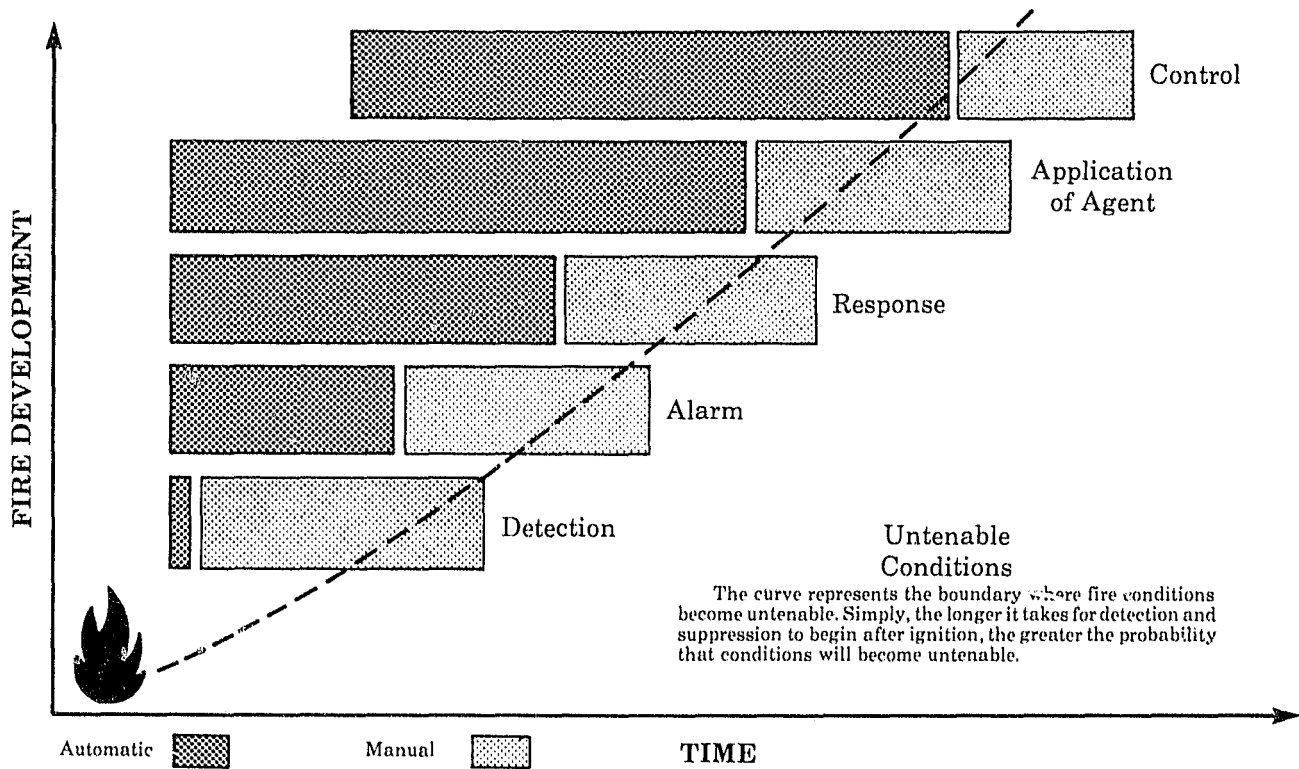

Figure 6.1 Margin of Safety in Manual vs. Automatic Systems

Manual Systems

As Figure 6.1 shows, for manual systems there is a definite lapse from the time the fire is detected until the alarm is sounded, and again until there is a response to the alarm, and so on. The goal of manual detection and suppression is to keep the time lapse between phases as short as possible, never allowing conditions to become untenable. This requires rapid response and adequate training of personnel and proper equipment.

In a fire situation, the first moments of fire development are critical. Unfortunately, this is the point at which human response is usually unreliable, unless training is continuous and intensive. In fact, under stress conditions, the actions of a fire brigade are often questionable.

Automatic Systems

In terms of time, even the most efficient manual system is no match for a correctly operating automatic system. Standard sprinkler systems, for example, have devices which automatically give an audible alarm in case of sprinkler operation.

What is the significance of early detection and warning to building occupants?

Early detection and warning are vital for providing adequate time for evacuation of building occupants. As Figure 6.1 shows, an automatic sprinkler alarm sounds virtually at the same time the fire is detected. Also, in that instant, a sprinkler responds and applies water to the seat of the fire, permitting fire conditions to be checked immediately. Because there is little or no time lapse from detection through application of agent with an automatic system, the chance of a fire becoming untenable is reduced significantly.

Only in rare instances have sprinkler systems failed to control fires. The failures are rarely caused by the sprinklers themselves, but rather by the lack of water to support the system. Some 117,700 fires in sprinklered buildings have been reported to the National Fire Protection Association since 1897. Of these, 96 percent of the sprinklers showed satisfactory performance.

The superiority of automatic systems becomes even more significant when the relationship of detection and suppression activities to the objectives of the Simplified Fire Safety System is examined. Because automatic sprinklers control the fire, they may allow more time for occupants to evacuate a fire area or remain in the building. Thus, the life safety objective is more easily achieved.

**RELATIONSHIP TO
FIRE SAFETY
OBJECTIVES**

Why is it important that an area remain tenable as long as possible?

There are at least two advantages to this aspect of sprinkler protection. First, occupants are less likely to panic in their attempt to evacuate the area. Less panic means more efficient egress. Second, there is a better chance for fire service personnel to begin rescue and extinguishment operations and, thus, to save occupants.

Automatic sprinklers also provide a better chance of reducing property loss and limiting downtime. Effective application of water by sprinklers to the seat of the fire permits more rapid control of fire conditions and minimizes water damage. Both aspects protect against destruction of property and limit downtime.

Although it is not a fire safety objective, economics is an important consideration that impacts on the total system. Insurance companies often offer significant reductions in premiums for premises where sprinklers are installed. This savings may more than offset the initial cost of installation. Of equal economic importance are the many building code trade-offs allowed when sprinklers are installed.

What trade-off is permitted for means of egress when sprinklers are installed?

As discussed previously, the *Life Safety Code* permits travel distances to be 50 percent longer in some instances if sprinkler protection is provided.

When automatic sprinklers are used in correctional facilities, achieving the objective of security may present a potential problem. First, because sprinkler piping can be used as a support for suicide by hanging, all piping must be concealed or in other ways be made inaccessible to inmates. A second argument against sprinklers in correctional facilities is the problem of vandalism. However, the installation of sprinkler systems in many correctional facilities has proved that vandalism is not a significant problem. Three reasons automatic sprinklers present few vandal problems are: (1) peer pressure (other inmates do not want their personal property wet); (2) ease of vandal identification (the person setting off the sprinkler would be wet); and (3) personal discomfort (arising from a wet mattress and other wet personal belongings).

The fact is that automatic sprinklers provide one of the safest methods of fire suppression and actually help to fulfill the security objective. In riot situations, for example, water can be discharged on fires without involving correctional personnel or fire fighters. Sprinklers have been and are being used very successfully in correctional facilities throughout the United States and Canada, including: Orlando, Florida; Baltimore, Maryland; Nashville, Tennessee; Los Angeles, California; and Saint John, New Brunswick. In its one and a half years of existence at the Saint John City Detention Center, the sprinkler system has not once been vandalized or subject to any other breach of security.

METHODS OF CONTROL

As previously discussed, detection and suppression activities involve three distinct stages: detection, alarm, and suppression. Each stage can be manual or automatic. Methods of control related to this goal reflect these stages: provide reliable early warning detection; provide reliable alarm systems; provide reliable suppression.

AVAILABLE TECHNOLOGY

Imagine fighting a fire in a modern high rise with buckets of water. Although there may be some discussion about the current state-of-the-art in fire protection technology, there is no doubt

that modern building design would not be possible without automatic detection and suppression systems. They also make the job of the fire fighter easier and far more efficient.

Of all the goals of the Simplified Fire Safety System, detection and suppression activities offer the most technological alternatives. Included are various types of detection and alarm equipment, automatic sprinklers, standpipes, water distribution systems, portable extinguishers, and self-contained breathing apparatus (SCBA).

In any fire situation, early detection is necessary to ensure that occupants will be safely evacuated, the fire department rapidly notified, and suppression initiated. It has been stated that automatic sprinklers automatically provide detection, alarm, and suppression at the same time. There is, however, detection equipment that can be used in conjunction with either an automatic sprinkler system or manual suppression. Among this detection equipment, the most common devices are three basic types of fire detectors: heat, smoke, and flame.

Heat detecting devices fall into two general categories: (1) those that respond when the detection element reaches a predetermined temperature (fixed-temperature types), and (2) those that respond to an increase in heat at a rate greater than some predetermined value (rate-of-rise types). Some devices combine both the fixed-temperature and rate-of-rise principles.

Fixed-Temperature Heat Detectors: The most widely used fixed-temperature heat detector signaling systems are thermostats of the bimetallic type. Bimetallic materials are made of two metals bonded together. Because each metal expands at a different rate, the bimetallic strip or disk will bend when heated, causing a movement which results in closing an electrical contact. This completes the circuit which activates an alarm for the detection system. Generally, fixed-temperature detectors alarm when the bimetallic strip or disk reaches a temperature of 125 °F (57.6 °C).

Rate-of-Rise Heat Detectors: The second category of heat detecting devices is rate-of-rise detectors. These detectors alarm when the rate of temperature increase at the operating element exceeds a stated rate (usually 15 °F per minute [8.3 °C per minute]). Heat detectors that operate on the rate-of-rise principle offer several advantages. These are summarized in Table 6.2.

Combined Rate-of-Rise and Fixed-Temperature Detectors: A type of heat detector that is finding increased application is the combined rate-of-rise and fixed-temperature detector.

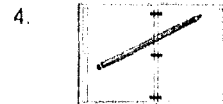

4. DETECTION AND SUPPRESSION ACTIVITIES
Available Technology — Detection Systems

Types	Examples
1.	
2.	
3.	
4.	

Location and Spacing

DETECTION SYSTEMS

Your discussion of detection systems should be augmented with slides showing photographs and schematics of the operation of each type of detector. Transparencies lend themselves well to schematics that diagram the operation of the detector, e.g., bimetallic strip. Manufacturers of detection and suppression equipment are a good source of schematics. Other

Heat Detectors

diagrams can be located in the 14th edition of the *Fire Protection Handbook*, published by NFPA.

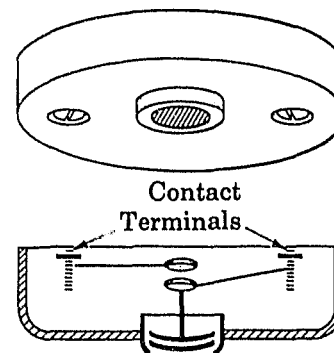

Fig. 6.2 A bimetallic, snap-action disc, fixed-temperature device. Heat causes the snap disc to bend until contacts close.

Which important feature of each type of detector makes the combined rate-of-rise and fixed-temperature detector particularly effective?

This type of detector takes advantage of the capability of the rate-of-rise feature to sense and respond rapidly to a fast fire, and the fixed-temperature feature to respond when the growth of fire is slow — so slow that the rate-of-rise capability might never come

Table 6.2	
RATE OF RISE DETECTORS vs. FIXED-TEMPERATURE DETECTORS	
ADVANTAGES	
<i>Rate of Rise</i>	<i>Fixed Temperature</i>
<ul style="list-style-type: none"> • Can be set to operate more rapidly. • Effective across a wide range of ambient temperatures. • Recycle rapidly and are more speedily available for continued service. • Tolerate slow increase in ambient temperature without giving alarm. 	<ul style="list-style-type: none"> • Operate at a prerated temperature even if rate of rise is extremely slow. • Revert to original condition with decrease in temperature. • Not destroyed or permanently damaged by operation.
DISADVANTAGES	
<ul style="list-style-type: none"> • Susceptibility to false alarms where there is rapidly increasing ambient temperature that is not the result of hostile combustion. • May fail to respond to fire which propagates very slowly. 	<ul style="list-style-type: none"> • Nonadjustable from prerated temperature. • Susceptibility to false alarms (bimetallic strip).

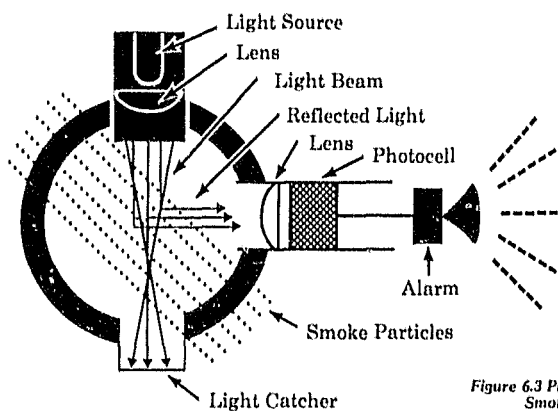

Figure 6.3 Photoelectric Smoke Detector

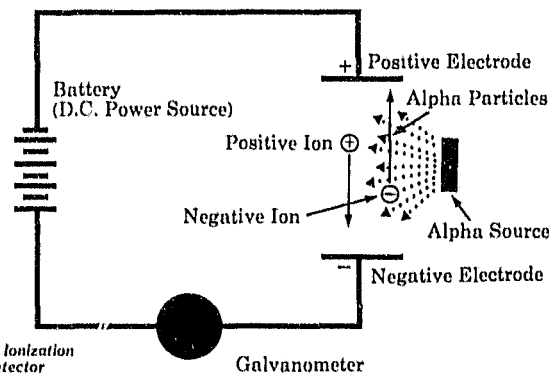

Figure 6.4 Ionization Smoke Detector

into play. Heat detectors are not recommended for life safety because they do not detect the presence of smoke and toxic gases, the principal cause of death in fires.

The second basic type of fire detector is a smoke detector. Smoke detectors respond to both visible and invisible products of combustion. Common types of smoke detectors include photoelectric and ionization detectors (see Figs. 6.3 and 6.4). Photoelectric detectors operate on the principle that smoke entering a light beam either obscures the beam's path or reflects light into a photocell.

In the ionization detector, air in the ionization chamber is made electrically conductive (ionized) by alpha particles emitted by a minute source of radioactive material. A voltage applied across the ionization chamber causes a very small electrical current to flow as the ions travel to the electrode of opposite polarity. When invisible or visible combustion particles enter the ionization detection (or sampling) chamber, they interrupt the small current between the two electrodes. The reduced current flow increases the voltage on the electrodes, which at a predetermined level results in an alarm.

Flame detectors are a third basic type of fire detector. A flame detector responds to the appearance of radiant energy, whether visible or invisible to the human eye. These detectors are sensitive to glowing ambers, coals, or actual flames that radiate energy of sufficient intensity and spectral quality to initiate response of the detector. Two common types of flame detectors are infrared and ultraviolet.

The type of fire detector for an area or location should be chosen based on the anticipated fire hazard. For example, a photoelectric or ionization-type smoke detector might be the best choice where the anticipated hazard is smoldering ignition. On the other hand, where rapid development of open flame conditions might occur (for example, flammable liquid fires), flame detectors will detect the presence of fire in milliseconds, before smoke detectors would.

Smoke Detectors

Flame Detectors

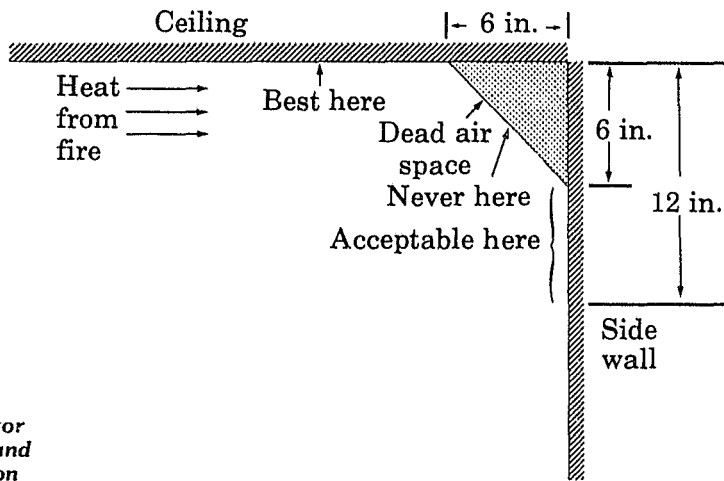

Figure 6.5 Detector location at wall and ceiling intersection

Detector Location and Spacing

5.



DETECTOR LOCATION and SPACING

Include diagrams of the following:

- Wall and ceiling intersection
- Peaked ceilings
- Sloped ceilings
- Bays

6. Use a transparency to explain these points.

As important as the choice of the appropriate fire detector is its location and spacing. NFPA 72E, *Automatic Fire Detectors*, gives detailed requirements on both locating and spacing of detectors. It may be helpful to review several general guidelines from the Standard that relate to locating and spacing fire detectors.

In locations such as living areas, cafeterias, and places of assembly, place smoke detectors on ceiling areas near the center of rooms, on upper wall surfaces within six to twelve inches of ceilings, or at tops of stairwells away from obstructions such as beams or large lighting fixtures (see Fig. 6.5). Wall locations are preferred where radiant panel ceiling heating systems will create thermal barriers at ceiling level.

When placing detectors, consider the room airflow patterns from mechanical air distribution systems (see Fig. 6.6). Stagnant areas can occur which will prevent smoke from reaching detectors (for example, in corners of a room). Moreover, avoid locating detectors in or near the supply air stream from air registers or diffusers, or where smoke can be diluted by return airflow from other parts of a building where there is no fire (for example, near return air grilles located at the top of stairways). Placement in these locations may purge detectors of smoke, thus preventing detection of fire.

ALARM SYSTEMS

The advantages of early detection can be reduced unless there is a subsequent alarm warning. Alarm systems, or, as they are sometimes called, protective signaling systems, are another aspect of technology related to detection and suppression activities.

Functions

An alarm system can be designed to serve many functions. These include: notifying occupants so they can evacuate the area when there is a fire; summoning organized assistance to under-

take, or assist in, fighting the fire; activating fire control equipment; and supervising extinguishing systems to assure their operability when needed. The number of functions performed by an alarm system depends on the type of system.

One important purpose of an alarm system is to notify occupants to evacuate. Evacuation alarms range from simple electrically operated bells to intricate devices intended to warn the occupants in large hotels, institutions, or multi-occupancy office buildings. Since occupants of correctional facilities cannot initiate any self-preservation actions, it is important that emergency operating procedures be in effect. In this way, staff and inmates recognize that life saving procedures will be initiated with the alarm. Another method of maintaining control in an emergency situation is the inclusion of a voice annunciation with the alarm.

There are two basic principles to follow in setting up an alarm system so that it will notify organized assistance. First, the system should be designed to transmit the alarm signal to the fire department or assistance agency as soon as possible. Alarm systems that use a local signal to alert an employee whose duty it is to summon the fire department often fail because the employee misjudges the extent of the fire or overestimates his or her ability to deal with the situation. The second principle to follow in setting up an alarm system that notifies assistance is to make certain that the signal received at the fire department or assistance agency specifically locates the site of the fire, or, as a minimum, localizes the source of the signal to a building or area so that the fire can be quickly located.

Sophisticated automatic protective signaling systems are commonly used to monitor fire extinguishing systems, such as automatic sprinkler systems. Supervision implies that something can and will be done about an abnormality which the system signals. It assures that the system is continuously operable in all essential respects and that it can perform its intended function.

7. 
- AVAILABLE TECHNOLOGY —
 Alarm Systems
 Functions
 Important Considerations
 Equipment/Examples
 Manual
 Automatic

Figure 6.6 Detector location in rooms with mechanical air distribution systems



Alarm or signaling systems that activate fire control equipment are included in automatic sprinkler systems. When a heat-resistive component of the sprinkler reacts to the fire, the nozzle is opened allowing water to flow, an alarm is sounded, and suppression begun all at the same time. The alarm system is activated by an electric water-flow alarm switch. Operation of the alarm signal may automatically summon assistance (either the fire department or the assistance agency) for fighting the fire and may activate evacuation alarms.

Manual Alarm Systems

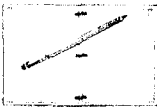
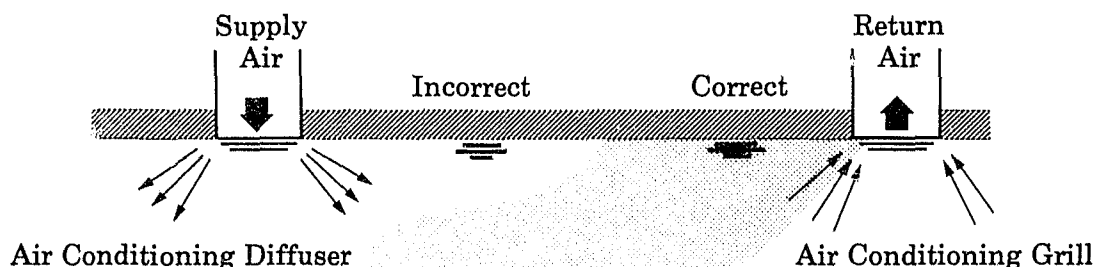
8. As with detectors, you should augment your discussion of manual and automatic alarm systems with appropriate slides. Audiovisual materials about detectors are often available from detector manufacturers.

Automatic Alarm Systems

8. Manual alarm systems employ the familiar fire alarm boxes or manual pull stations. Operation of the switch activates an audible alarm and may send a signal to either the fire department or an assistance agency. Manual alarm stations may be connected to systems with automatic detection.

Automatic alarm systems involve some type of automatic fire detection for providing an alarm signal within the protected premises (for example, heat, smoke, or flame detectors, or water-flow alarms in automatic sprinklers). This alarm signal can also be connected to an assistance agency such as a central station. The central station has trained and experienced personnel continually on duty to receive signals, retransmit fire alarms to the fire department, and take whatever action supervisory signals indicate is necessary. Central stations customarily serve a number of properties of different ownership. An alternative to an assistance agency is a station that is managed locally by a full-time staff. The staff would function in much the same way as those in the central station.

Alarms and Margin of Safety

9.



ALARM AND MARGIN OF SAFETY
(For Level I)
Figure 6.6

9. Earlier in this chapter, manual systems were compared to automatic systems (see the section "Reliability"). It was established that early detection of fire and subsequent alarm are vital for allowing occupants adequate time for evacuation. If the time needed to detect the presence of fire and warn building occupants can be reduced, a corresponding margin of safety can be provided. Using Figure 6.1, Margin of Safety, the detection and alarm phases can be combined in order to graphically represent this margin of safety (see Fig. 6.7).

According to Figure 6.7, which type of detection and alarm system, manual or automatic, offers a greater margin of safety for occupants?

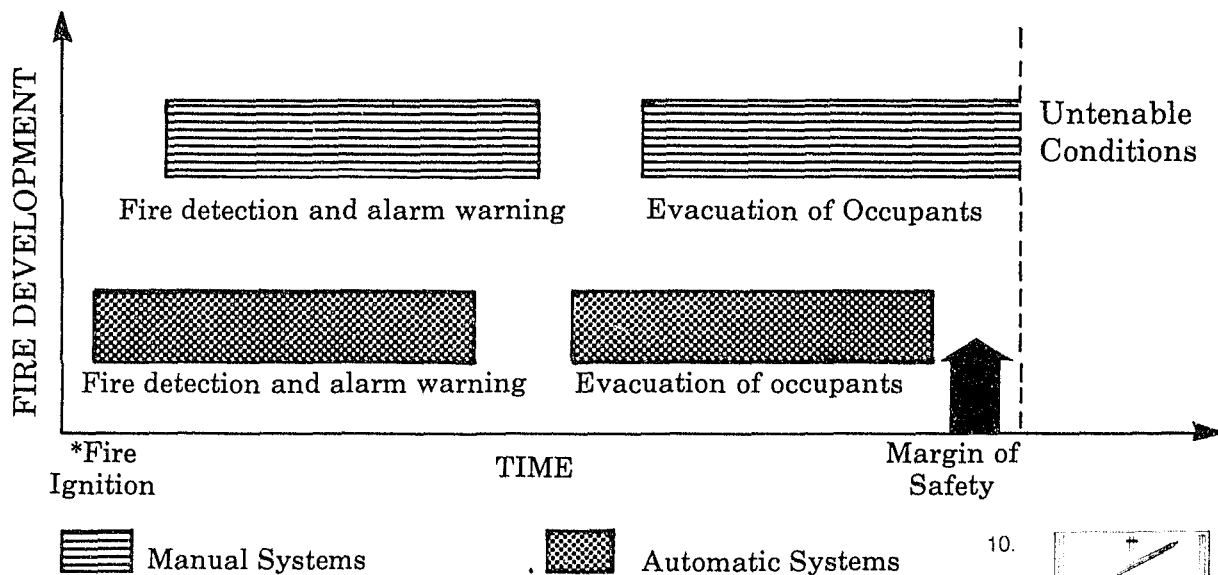

Figure 6.7 Revised Margin of Safety

Figure 6.7 indicates that an automatic detection and alarm system is the most reliable option for providing occupants with a margin of safety for evacuation. Automatic suppression systems also exhibit a higher degree of reliability than manual suppression systems.

The technology related to fire suppression is extremely broad and complex. Therefore, only those areas most relevant to correctional facilities will be discussed: technology relating to manual suppression (portable extinguishers, self-contained breathing apparatus, standpipes, and hydrants), and automatic suppression (automatic sprinkler systems).

Portable fire extinguishers are the first line of defense against fires. In fire emergencies, seconds count and the first two minutes are most critical. This is the time to use first-aid fire extinguishment. The effectiveness of first-aid measures depends upon two factors: the availability of the appropriate portable extinguishers and the availability of people who know how to use the equipment.

The first factor involves considerations such as selection, placement, and distribution of portable extinguishers, criteria which are discussed in this section. The second factor relates to training. Although operational characteristics of various portable extinguishers will be discussed in this section, the proper use of extinguishers depends on hands-on training, which is clearly beyond the scope of this manual. However, it is important that you, as a corrections official, implement and maintain some type of organized hands-on training, including instruction on the proper use of portable extinguishers for all personnel in your correctional facility.

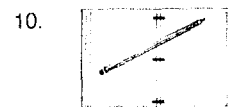

10. AVAILABLE TECHNOLOGY —
Portable Fire Extinguishers
Selection Criteria

- 1.
 - 2.
 - 3.
 - 4.
 - 5.
 - 6.
- Placement
Distribution

SUPPRESSION SYSTEMS

10. Portable Extinguishers

11. Your primary reference in discussing the selection, placement, and distribution of portable extinguishers should be NFPA 10, *Portable Fire Extinguishers*. You should also be aware that the Occupational Safety and Health Administration (OSHA) adopts the requirements of NFPA 10. As mentioned earlier, there are several audiovisual programs that deal with portable fire extinguishers. A slide/tape program, *Portable Fire Extinguishers: Selection, Placement and Use*, provides an excellent way to supplement your presentation of the selection, placement, and use of portable fire extinguishers. Although the information is more appropriate for supervisory personnel, all levels of corrections officials should benefit from the information. This program is available from the National Fire Protection Association, catalogue No. SL-47.

Selection of Extinguishers: Selecting the appropriate portable extinguishers for a fire emergency depends on six criteria: the kind of materials or the class of fire they would extinguish; the potential severity of fire; the capability of people using the extinguishers; the extinguishers' relative "fire-killing" power; the particular extinguishing agent they contain; and their propellant system.

It is important to be alert that certain kinds of extinguishers are obsolete and should be removed from service. These include the old inverting extinguishers made of copper or brass which may explode when suddenly pressurized upon inversion, and extinguishers containing the toxic substances chlorobromomethane or carbon tetrachloride.

Selection Criteria: Classes of Fire

To facilitate the proper use of extinguishers on different types of fires, NFPA 10, *Portable Fire Extinguishers*, classifies fire into four types.

12

12.

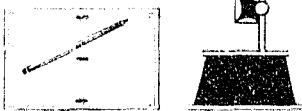

SUMMARY OF THE A, B, C, AND D's
OF PORTABLE FIRE EX-
TINGUISHERS
Table 6.3





- Class A: Fires involving common combustible materials such as wood, cloth, paper, rubber, and many plastics.
- Class B: Fires involving flammable or combustible liquids such as oils, greases, tars, oil-base paints, lacquers, and flammable gases.
- Class C: Fires involving energized electrical equipment where there is a shock hazard. (Where electrical equipment is deenergized, extinguishers for Class A or Class B fires may be used safely.)
- Class D: Fires involving combustible metals such as magnesium, titanium, zirconium, sodium, lithium, and potassium.

Some portable extinguishers are of primary value on only one class of fire; some are suitable on two or three classes; none is suitable for all four classes.

Extinguishers are selected according to the class of fire for which the extinguisher is intended, that is, Class A, Class B, Class C, and Class D fires. A Class A fire involves ordinary combustibles — wood, paper, and cloth. Class B fires involve flammable liquids, such as paints, thinners, gasoline, and oil. Class C fires involve energized electrical equipment; and Class D fires involve combustible metals.

Extinguishers manufactured today are labeled with a classification system so that the user may quickly identify the class of fire for which a particular extinguisher may be used. Table 6.3 summarizes the classification system contained in NFPA 10, *Portable Fire Extinguishers*. In addition

to the classification symbol and color, the type of fire, and description of materials, Table 6.3 lists types of extinguishers that are effective for each particular class of fire.

Table 6.3			
SUMMARY OF THE A, B, C, AND D 'S OF FIRE EXTINGUISHERS			
CLASSIFICATION SYMBOL (Label Color in Parentheses)	TYPE OF FIRE	DESCRIPTION OF MATERIALS	TYPE OF EXTINGUISHER
<p>ORDINARY</p>  <p>COMBUSTIBLES (Green)</p>	Ordinary Combustibles	Materials such as wood, paper, cloth, fiber, and many plastics.	Water, foam, aqueous film forming foam (AFFF), soda acid, multipurpose dry chemical, Halon 1211.
<p>FLAMMABLE</p>  <p>LIQUIDS (Red)</p>	Flammable Liquids	Liquids such as paint, paint thinner, gasoline, oil, tar, solvents, fat, greases, and similar materials.	Dry chemical, multipurpose dry chemical, carbon dioxide, Halon 1211.
<p>ELECTRICAL</p>  <p>EQUIPMENT (Blue)</p>	Electrical Equipment	Energized electrical equipment such as overheated fuse boxes and other electrical sources and wiring. Classification refers to source of ignition rather than to fuel as fires are classes A and B in terms of fuel.	Dry chemical, multipurpose dry chemical, foam, AFFF, carbon dioxide, Halon 1211.
<p>COMBUSTIBLE</p>  <p>METALS (Yellow)</p>	Combustible Metals	Metals such as magnesium titanium, zirconium, sodium-potassium alloys, and so on.	Dry powder with sodium chloride or graphite base, agents specific to particular metal hazards.

For what class of fire would a dry chemical portable extinguisher be effective?

A dry chemical portable extinguisher, as well as a carbon dioxide extinguisher, is effective on both Class B and Class C fires.

Selection Criteria: Hazards of the Area

The initial selection of the type and capacity of a portable extinguisher is based on the hazards of the area to be protected, that is, the potential severity of the fire. In order to provide a simplified method for determining the probable size of a fire, NFPA 10 has established three hazard levels. These hazard levels are different from those levels delineated in NFPA 13, *Installation of Sprinkler Systems*.

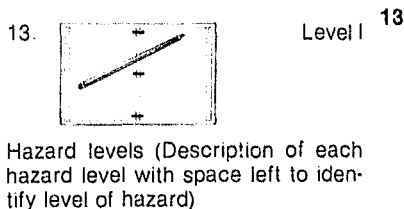

1. Light hazards (low): the amount and density of combustible materials is such that a fire might be expected to be of small size. This may include offices, schoolrooms, churches, assembly halls, telephone exchanges.

2. Ordinary hazards (moderate): the amount of combustible materials or flammable liquids is such that any fire might be expected to be of moderate size. Examples here would be mercantile storage and display areas, automobile showrooms, parking garages, light manufacturing areas, warehouses not classified as an extra hazard, shop areas of schools.

3. Extra hazards (high): the amount of combustible materials or flammable liquids is such that any fire might be expected to be of severe magnitude. This would include wood-working operations, auto repair and aircraft service areas, warehouses with materials piled over fifteen feet high, or operations using paint, dipping, or other process involving flammable liquids.

What level of hazard would you expect in cellblock areas in your correctional facility?

Cellblock sleeping and living areas would probably represent only light hazard conditions. It is likely that storage areas containing cleaning and maintenance supplies, paints, and other solvents might be ordinary hazards.

Selection Criteria: Capabilities of Users

The third criterion which demands consideration in selecting the appropriate portable extinguisher is the capabilities of people who will use the extinguisher. If, for example, the extinguisher cannot be lifted off the wall, its use for fire protection is nonexistent.

To increase user capability of portable extinguishers, a program to inform all relevant personnel of the location and operation of extinguishers should be mandatory. Only training and self-confidence in the use of portable extinguishers will assure their proper usage in a fire emergency situation.

14

Selection Criteria: "Fire-Killing" Power

In addition to the letter code of A, B, C, and D, extinguishers carry a numerical rating based on tests conducted by Underwriters Laboratories Inc. Thus, the letter indicates the class of fire on which the extinguisher is used, and the numeral (preceding the letter) signifies the relative "fire-killing" power, or extinguishing effectiveness. For example, the rating "10-A" signifies an extinguisher for ordinary combustibles with a potential five times greater than an extinguisher labeled "2-A." Extinguishers for use on Class C or Class D fires are not required to have a numeral rating.

14. Hands-on training is the only way to assure proper use of extinguishers in an emergency. Local fire officials and portable extinguisher manufacturers can lend assistance training personnel in the proper use of extinguishers. A training program for this purpose should be officially instituted.

As a means of familiarizing students with the operation and use of different types of extinguishers, you may wish to use the 16-mm film *The A, B, C's and D's of Portable Fire Extinguishers*, available from the Factory Mutual Engineering System.

For what materials would you use an extinguisher labeled "5-B"? How would a 5-B extinguisher compare to one labeled "40-B"?

A 5-B extinguisher is intended for use on fires involving flammable liquids. A 40-B extinguisher would have eight times the "fire-killing" power on flammable liquids fires as a 5-B rated extinguisher.

Some extinguishers are rated for more than one class of fire. For example, dry chemical and carbon-dioxide are effective on both Class B and Class C fires.

On what types of fires would an extinguisher labeled 10-B:C be used?

A 10-B:C extinguisher is effective on fires involving flammable liquids as well as energized electrical equipment. The "10" refers to the extinguisher's effectiveness on Class B fires only; there is no rating system for rating Class C effectiveness.

Selection Criteria: Extinguishing Agent

Table 6.3 lists many of the extinguishing agents used for the different classes of fire. The following exercise will help you to associate the different extinguishing agents with the class of fire for which they are effective. As an additional aid, beside each class is a pictorial label. This label represents a marking system that combines the selection of an extinguisher according to the class of fire and hazard. Using Table 6.3, list the appropriate agents for the class or classes of fire specified.



For Class A Types



For Class B:C Types



For Class A:B:C Types

Selection Criteria: Propellant System

Because usage is the primary consideration, portable extinguishers can be selected according to their operational characteristics or propellant system. Basically, two types of water-base extinguishers are manufactured: stored-pressure (pressurized) tanks and pump tanks. Stored-pressure tanks are always ready, have a pressure-check gauge, and have a longer range. Pump tanks, on the other hand, are easily filled and maintained. The disadvantage of the pump tank extinguisher (hand-carry type) is that it cannot be operated while being carried. The disadvantage of all water-base extinguishers is freezing; antifreeze should be used if there is danger of freezing (salt should not be used in extinguishers because of its corrosive effect).

There are two types of dry chemical extinguishers: cartridge and stored-pressure. Both are rechargeable. The stored-pressure type is available with either a rechargeable shell or a disposable shell. For carbon dioxide and Halon extinguishers, no propelling agent is required. In both of these extinguishers the agent is stored under pressure in its liquefied state. Actuation of the extinguishers causes the stored agent to be released as a gas.

Placement of Extinguishers: Extinguishers should be located strategically throughout all areas. Locations should be selected that will:

- provide uniform distribution,
- provide easy accessibility,
- be relatively free from blocking by storage and equipment,
- be near the normal path of travel,
- be near entrance and exit doors,
- be free from the potential of physical damage,
- be readily visible.

For certain operations, such as welding, extinguishers should be immediately available to personnel working on equipment.

The majority of portable extinguishers are mounted to walls or columns, at positions where they can be easily reached and removed. According to Occupational Safety and Health Act (OSHA) regulations, portable extinguishers having a gross weight of forty pounds or less should be mounted so that the top of the unit is not more than five feet above the floor. Extinguishers having a gross weight of more than forty pounds should be installed not more than three and a half feet above the floor. All extinguishers should be mounted at least six inches above the floor.

15. Because selecting the correct extinguisher is so important, you should provide a summary of the selection criteria. For Level I personnel this summary should include the advantages and disadvantages of the different types of extinguishers.

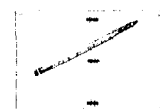

LEVEL I

SELECTING THE CORRECT
EXTINGUISHER
Type of Extinguisher
Class of Hazard
Advantage
Disadvantage

You may want to complete "Type of Extinguisher" and have students fill in other information during your discussion or summary.

15

16

16. Stress to supervisory personnel that placement and distribution of portable extinguishers should be determined by a qualified fire protection engineer.

Distribution of Extinguishers: Distribution of extinguishers is calculated by square footage, hazard level, and travel distance to any extinguisher. For example, one 2-A extinguisher should be allotted for every 2,000 square feet in an extra hazard area, but is sufficient for every 6,000 square feet in a light hazard area. In no case, however, should a Class A extinguisher be located more than seventy-five feet from any point in a room. NFPA 10 provides detailed guidance on placement and distribution of portable extinguishers.

Extinguisher Inspection and Maintenance: Both periodic inspection and maintenance of portable extinguishers are crucial to their operation. This responsibility should be clearly assigned and carried out. A checklist of some items that should be inspected monthly is included here. Use it as a guideline in forming a checklist tailored to the needs of your facility.

It is imperative that, after any use, an extinguisher be recharged immediately. This will assure proper operation of a portable extinguisher when it is needed.

17. Appendix A of NFPA 10 provides detailed guidance for inspection and corrective actions for different types of extinguishers. In addition, all extinguisher manufacturers include lists of items that are specific to their particular brand of extinguisher. As in all areas dealing with fire protection equipment, a fire protection engineer is your best source of advice.

INSPECTION CHECKLIST

	O.K.	Needs Corrective Action
Extinguisher in designated location.	_____	_____
Access or visibility to extinguisher not obstructed.	_____	_____
Operating instructions legible and facing outward.	_____	_____
Seals or tamper indicators intact.	_____	_____
Extinguisher fully charged and operable.	_____	_____
No obvious physical damage, corrosion, leakage, or clogged nozzles.	_____	_____

18.

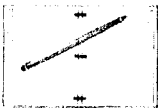

AVAILABLE TECHNOLOGY --
Self-Contained Breathing Apparatus
Purpose
Types
Inspection Procedures

Self-Contained Breathing Apparatus

18 One type of equipment used in fire fighting operations deserves special mention: self-contained breathing apparatus, or SCBA. Most correctional facilities own several SCBA's but, because personnel and occupants, even fire brigade members, are not familiar with their use, they become virtually worthless. In fire fighting and rescue operations, especially in an atmosphere laden with smoke and toxic gases, SCBA's are necessary for survival and may be the difference between rescuing inmates trapped by a fire or certain death.

19. Your discussion of SCBA's will be more meaningful if you have a sample of the type of SCBA used in your facility. In addition, all Level II personnel should be trained in the use of SCBA. Local fire officials can provide the expertise for training.

Breathing apparatus carried on fire department vehicles requires self-contained equipment having one-half hour minimum

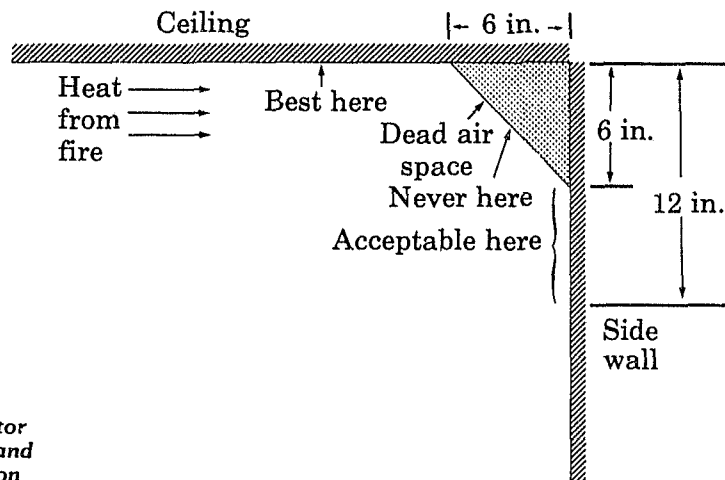

Figure 6.5 Detector location at wall and ceiling intersection

Detector Location and Spacing

5.



DETECTOR LOCATION and SPACING

- Include diagrams of the following:
- Wall and ceiling intersection
 - Peaked ceilings
 - Sloped ceilings
 - Bays

6. Use a transparency to explain these points.

As important as the choice of the appropriate fire detector is its location and spacing. NFPA 72E, *Automatic Fire Detectors*, gives detailed requirements on both locating and spacing of detectors. It may be helpful to review several general guidelines from the Standard that relate to locating and spacing fire detectors.

In locations such as living areas, cafeterias, and places of assembly, place smoke detectors on ceiling areas near the center of rooms, on upper wall surfaces within six to twelve inches of ceilings, or at tops of stairwells away from obstructions such as beams or large lighting fixtures (see Fig. 6.5). Wall locations are preferred where radiant panel ceiling heating systems will create thermal barriers at ceiling level.

When placing detectors, consider the room airflow patterns from mechanical air distribution systems (see Fig. 6.6). Stagnant areas can occur which will prevent smoke from reaching detectors (for example, in corners of a room). Moreover, avoid locating detectors in or near the supply air stream from air registers or diffusers, or where smoke can be diluted by return airflow from other parts of a building where there is no fire (for example, near return air grilles located at the top of stairways). Placement in these locations may purge detectors of smoke, thus preventing detection of fire.

ALARM SYSTEMS

The advantages of early detection can be reduced unless there is a subsequent alarm warning. Alarm systems, or, as they are sometimes called, protective signaling systems, are another aspect of technology related to detection and suppression activities.

Functions

7 An alarm system can be designed to serve many functions. These include: notifying occupants so they can evacuate the area when there is a fire; summoning organized assistance to under-

service life. Available standards also require that fire department officials have respiratory protective equipment inspected at regular intervals, preferably weekly, but not less than monthly. These requirements should also extend to those SCBA's provided in all correctional facilities.

There are three approved types of self-contained breathing apparatus available for fire fighting applications: the open-circuit "demand" or "pressure-demand" type, the closed-circuit system equipped with a cannister and a breathing bag, and the closed-circuit, oxygen rebreathing system. Your facility most likely has the open-circuit "demand" or "pressure-demand" type, and it is this type we will discuss.

The open-circuit "demand" or "pressure-demand" SCBA uses a tank of compressed air, a pressure regulator, and a face mask. With the demand type, when the wearer inhales, the regulator valve opens, allowing air to enter the mask. As the wearer exhales, the supply valve closes; the exhaled breath operates an exhaust valve and is vented to the atmosphere. The pressure-demand type of SCBA operates in a similar manner except that the mask is continually under slight pressure. This reduces the chances of toxic gases entering the mask, an added margin of safety for the user. With both types of SCBA, after each use, the tank should be refilled or replaced with a full tank before the apparatus is returned to storage.

Self-contained breathing apparatus should be used only after thorough training on the specific type of equipment.



What is one major requirement before anyone uses SCBA?

Protective breathing equipment should be used only after thorough training with the specific type of equipment used in the facility. This training must include practice in working under restricted breathing and visibility conditions.

A water distribution system is the basic element for both manual and automatic suppression. It provides water transfer from some supply source to a point of use for fire suppression purposes. Such a system may be publicly or privately owned.

Principal Components: As Figure 6.8 shows, the principal components of a water distribution system for fire suppression purposes include:

20 Water Distribution Systems



WATER DISTRIBUTION SYSTEMS
Figure 6.8

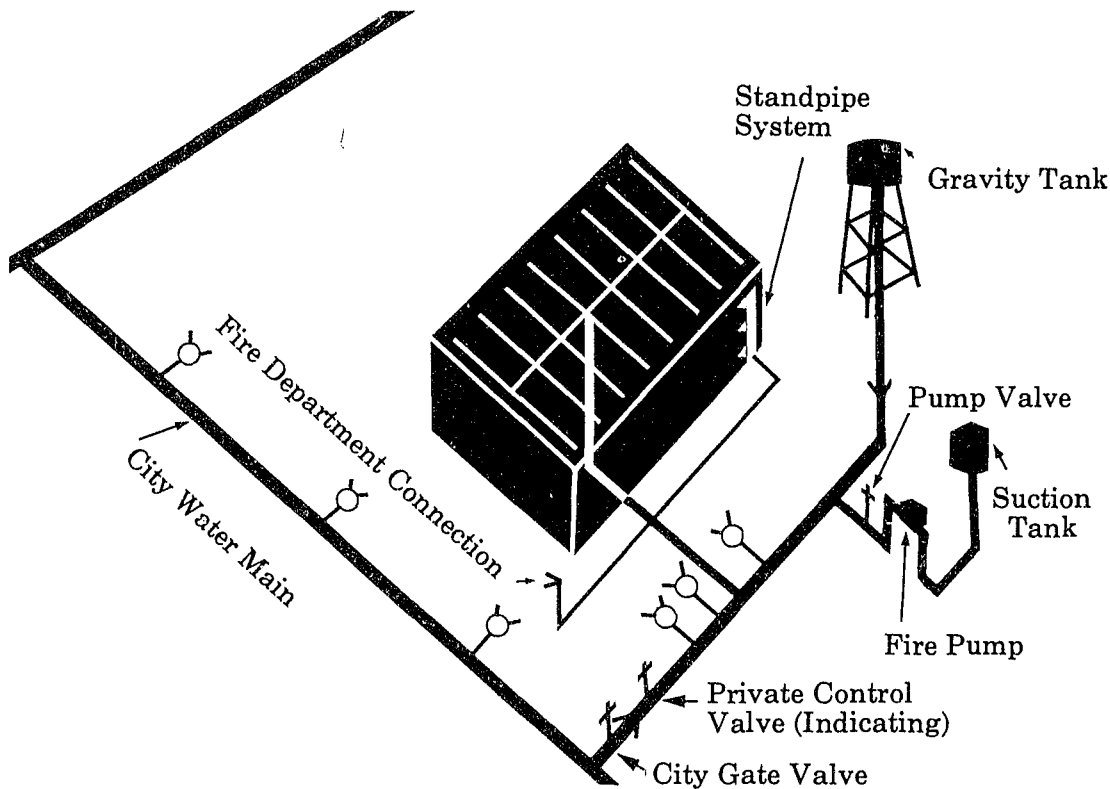
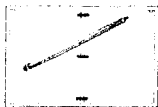

Figure 6.8 Water Distribution System

21.



AVAILABLE TECHNOLOGY —
Water Distribution Systems
Figure 6.8
Hydrants
Types
Inspection & Maintenance

Tailor your discussion of water distribution systems to the system used by your facility. This is especially important to Level II personnel who may be involved with some of the maintenance and inspection procedures of the components of a water distribution system. Include a tour to familiarize officials with all the components and any maintenance requirements they may have to perform on the system. In addition, you should point out any potential problems, deficiencies, or peculiarities of your system.

21

- A supply source. This source can be a public main, with or without a holding tank; gravity tank; suction tank with a fire pump; or pressure tanks.
- City gate valve. This valve controls the supply of water from the public main to the property.
- Private control valves. In most jurisdictions, these valves must be of the indicating type.
- Hydrants. These may be located on both the public main and on the property. On some buildings, the hydrants may be located on the building walls.
- Fire department connections. These enable fire department pumpers to feed water to standpipe and/or sprinkler systems. In this way they supplement the primary water source feeding sprinklers and standpipes.

Other components such as fire pumps, standpipes, and sprinklers are not a necessary part of a basic water distribution system because they comprise an internal, rather than an external, means of water distribution.

- Fire pumps. Fire pumps are used to supplement the water pressure available from public mains. They may be connected to a private water supply source, such as a gravity tank, suction tank, private reservoir, or the city main.

- Standpipes. Standpipes and hose systems provide a means for manual application of water to fires in buildings. They are a step up from the "first-aid" portable fire extinguishers.
- Sprinklers.

Regardless of the extent of fire protection that is provided by a facility, it is vital that a water distribution system, including the supply source, be capable of supplying water of adequate pressure and capacity.

Hydrants: One component of the water distribution system is a hydrant. Hydrants are the means by which fire department pumpers can tap onto the water supply and provide pressure for dry standpipes and hose streams. For these purposes, most hydrants have two 2½-inch outlets and one larger pumper outlet.

Hydrant Types

There are two types of fire hydrants in general use today. The most common is the base valve, or dry barrel, type where the valve controlling the water is located below the frost line. A dry barrel hydrant is used wherever there is a chance weather conditions will go below freezing. The other type of hydrant is the wet barrel (California). This hydrant is sometimes used when weather conditions are such that there is no danger of freezing.

Hydrant Location

In a private water system, hydrants should be located where they can be used quickly and with short hose lines that are not over 250 feet. At a minimum, enough hydrants should be available so that two hose streams can be provided at every part of the interior of each building not covered by standpipe protection.

Well-designed and installed hydrants present minimal maintenance difficulties. Maintenance routines for hydrants include an operating test, repair of leaks, lubrication, and painting. Dry barrel hydrants have a small drain near the base of the barrel that allows water to drain from the barrel when the main valve is shut. If this drain is working properly and the main valve is tight, water will drain from the barrel and will not freeze. After each use the hydrant should be checked to assure that it drains. If it does not drain, the water should be pumped out and the hydrant repaired.

Standpipes: Standpipes provide a means for manual application of water to fires in buildings. They are not intended to take the

22.

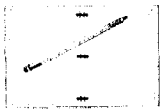

AVAILABLE TECHNOLOGY —
Standpipes

Class Description Use

I

II

III

Class, Type, and Location in my
facility

Inspection & Maintenance

22 place of automatic extinguishing systems. However, they are needed where automatic protection is not provided and in areas of a building not readily accessible to hose lines from outside hydrants.

Classification

- Class I systems are provided for use by fire departments and those trained in handling heavy fire streams. These systems have 2½-inch hose connections.
- Class II systems are provided for use by the building occupants until the fire department arrives. One-and-a-half-inch hose lines are connected to ¾- or ½-inch open nozzles or combination spray/straight stream nozzles with shutoff valves.
- Class III systems are provided for use by either fire departments and those trained in handling heavy hose streams, or by building occupants. Because of the multiple use, a Class III system is provided with both 2½-inch and 1½-inch hose connections.

Which class or classes of standpipes are intended for use by building occupants?

Standpipe and hose systems that are provided for use by occupants are either Class II or Class III. Persons must be thoroughly trained in the use of standpipe hose lines, including hands-on use. Hose reactions can be strong and may result in injury to an untrained person.

Wet and Dry Standpipe Systems

In addition to the three use classifications, standpipe systems are classified as either wet or dry. In a wet standpipe system, the supply valve is open and the water pressure is maintained at all times. Fire hose is immediately ready for use in wet systems. Also, the piping is supervised for leaks or a break. In other words, a leak will be detected by water flowing from the leak.

Unlike a wet system, a dry standpipe system has no permanent water supply. Water for this type of system is obtained by fire fighters connecting from ground-level hydrants to the fire department connection. Dry standpipes require extra inspection and hydrostatic testing to assure they have not rusted or been damaged.

Standpipes should be spaced to allow hoses to reach any fire. NFPA 14, *Standpipe and Hose Systems*, requires that all areas of the building be within 30 feet of a nozzle attached to not more than 100 feet of hose.

Inspection and Maintenance

In order to assure that standpipes are in working order, all standpipe and hose systems should be inspected periodically. Such an inspection will usually indicate maintenance requirements. The following checklist notes some of the parts of standpipe systems that should be inspected weekly. Since the checklist is general, it should be used as a guideline only. A thorough and specific list should be designed for the standpipe system in your facility.

STANDPIPE INSPECTION AND MAINTENANCE CHECKLIST

	Yes	No	Needs Maintenance (Location)
CLASS I STANDPIPES			
Are water supply control valves in open position?	-----	-----	-----
Is discharge valve, including control wheel, operable?	-----	-----	-----
Are threads on discharge outlets nonstandard or damaged?	-----	-----	-----
CLASS II and CLASS III STANDPIPE AND HOSE STATIONS			
Are water supply control valves in open position?	-----	-----	-----
Is discharge valve, including control wheel, operable?	-----	-----	-----
Are threads and gaskets on couplings damaged?	-----	-----	-----
Is hose dry and properly folded or racked?	-----	-----	-----
Is hose nozzle blocked or damaged?	-----	-----	-----
Are hose racks or reels damaged?	-----	-----	-----

So far, only the equipment used in manual suppression operations has been discussed. Manual suppression is a necessary part of any fire fighting operation. Indeed, there may be no other means of fire protection available. Modern building designs, however, demand fixed automatic fire protection. In addition, the extensive use of synthetic materials in correctional facilities for bedding and other furnishings, and for interior finishes, produces high smoke and toxic gas levels, making manual fire fighting difficult. The answer? Automatic sprinkler systems. In this section,

23

**Automatic
Sprinkler Systems**

23. An excellent overview to this section on automatic sprinklers is provided by the film *Automatic Sprinklers: The Myths and the Magic*. This film, available from the Factory Mutual system gives a nontechnical explanation of what a sprinkler is, how it operates, and its role in fire control.

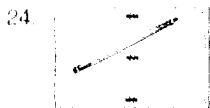

- 24
- AVAILABLE TECHNOLOGY —
Automatic Sprinklers
Effectiveness
Method of Extinguishment
Types of Systems
1. Wet pipe
2. Dry pipe
3. Pre-action
4. Deluge

24 the performance record, value, method of extinguishment, available systems, sprinkler heads, and basic maintenance procedures will be discussed.

As the record indicates, sprinklers are effective. Records compiled by the National Fire Protection Association indicate that automatic sprinkler systems are over 96 percent effective in suppressing or containing fires.

What is the principal reason for sprinkler system failure?



LEVEL I

25 This discussion may be held at any point while studying this section.
Concept: Supervisory personnel should be totally familiar with the argument supporting the installation of automatic sprinkler systems.
Activity:

(1) Although students should know the arguments for automatic sprinkler systems, they should also be familiar with some of the common arguments against installing sprinkler systems.

(2) In order to bring out both the arguments for and against sprinklers in correctional facilities, introduce a loosely-structured debate.

(3) Divide the students into two groups. One group will defend the "con" argument, the other group will defend the "pro" argument. It is the job of the "con" group to provide arguments (traditional, personal, or otherwise) against sprinklers in correctional facilities. Among these should be: security problems, false alarms, vandalism, suicide, financial limitations, and operational limitations.

It is the job of the "pro" group to anticipate "con" arguments and provide rebuttals encouraging installation. Among these should be:

- Only correctional facility officials who do not have sprinklers do not advocate their use.
- Sprinklers have been used successfully in facilities throughout the U.S. and Canada: Orlando, Florida; Baltimore, Maryland; Raleigh, North Carolina; New Orleans, Louisiana; Nashville, Tennessee; St. John, New Brunswick; Los Angeles.

25 The value of sprinklers is unquestionable. Properly installed and maintained automatic sprinklers offer the highest assurance of safety to life from fire. Their value is psychological as well as physical: they give a sense of security to occupants of buildings and minimize the possibility of panic. In correctional facilities where inmates cannot take advantage of early fire alarms and evacuate, this has added significance.

Automatic sprinklers are particularly effective for life safety because they detect the presence of fire, give warning of its existence, and apply water to the burning area, all at the same time. With sprinklers, there are seldom problems of access to the seat of the fire or of interference with visibility for fire fighting due to smoke.

Safeguarding life is reason enough for sprinkler protection. But its value extends to better protection of property, prevention of downtime, and reduction of water damage. Finally, sprinklers make good economic sense.

Why do sprinklers make good economic sense?

Although the capital investment may be sizeable, there are two facts that make sprinkler protection a sound business investment. First, insurance premiums may be reduced with the installation of sprinkler protection. Second, many building codes offer trade-offs

that help reduce building costs. Finally, from the standpoint of economics, sprinklers can often be installed at a discount in correctional facilities. Under the supervision of a qualified fire protection engineer, sprinklers can be installed in correctional facilities by inmates. Moreover, most correctional facilities have at least a small machine or repair shop with adequate fabricating capabilities for the installation.

Methods of Extinguishment: In a fire, sprinklers discharge water to extinguish the fire or prevent its spread from the area or room of origin. The water discharged from sprinklers cools burning materials by direct contact of water particles. Thus, the primary method of extinguishment of sprinklers is cooling and quenching burning materials. Sprinklers will then prevent the spread of fire by removing heat from the room and wetting unburned combustibles.

Types of Sprinkler Systems: There are four basic types of sprinkler systems: wet pipe, dry pipe, preaction, and deluge.

Wet Pipe Systems

Wet sprinkler systems represent about 75 percent of all sprinkler installations. The wet-pipe system contains water under constant pressure. When a fire occurs, the heat melts a solder link in each individual sprinkler, allowing water to flow through the open sprinkler to begin the suppression of fire immediately. A wet-pipe system is used in heated areas or where there is no danger that water will freeze in the pipes.

Dry Pipe Systems

Dry pipe sprinkler systems contain air under pressure. Compressed air in the system holds the dry valve closed, preventing water from entering the sprinkler piping. Upon actuation by heat, the sprinkler head opens, causing the air pressure to drop. The drop in air pressure in the piping allows the valve to open and water to enter the piping network and flow through the opened sprinkler heads. A dry pipe system is installed only when a wet-pipe system is impractical, for example, in rooms or buildings not heated and thus subject to freezing temperature.

Preaction Systems

The preaction sprinkler system is a dry pipe system in which air in the piping may or may not be under pressure. When a fire occurs, an independent fire detecting device in

California; Beaverton, Oregon; Lompoc, California.

- St. John has not had any incidence of vandalism, suicide, or drowning since installing sprinklers following a fatal fire there.
- Piping can be hidden.
- It is difficult to trip a sprinkler deliberately because of cell ceiling height.
- The individual responsible for tampering will be wet and dirty, as will his personal property (especially important in long-term facility).
- Peer pressure exists to avoid breaking prison routine by sprinkler discharge.
- Existing and advanced technologies in sprinkler design aid corrections (horizontal sidewall sprinklers, recessed heads, on/off heads, heads that will not support heavy weight).
- Sprinklers are necessary for true defend-in-place occupancy.
- Sprinklers are more cost-effective in long run than combination of other methods (use can sometimes be made of existing piping).

(4) Use chalkboard to record arguments.

(5) Each side will need a spokesperson.

(6) Allow each side 10 minutes to prepare arguments; 5 minutes each to present arguments; 2 minutes for summary by instructor and then a vote by entire group to "resolve" issue, hopefully "pro" sprinklers based on available evidence.

the protected area is actuated. This detection system opens the preaction valve, permitting water to flow into the piping and be discharged by any sprinklers that have been opened by the heat of the fire. Preaction systems are designed primarily to protect properties where there is danger of serious water damage as a result of damaged automatic sprinklers, broken piping, or false alarms.

Deluge Systems

The fourth type of sprinkler system is the deluge system. This system is similar to a preaction system except that all the sprinkler heads are open at all times. When heat from a fire actuates the fire detection system, the deluge valve is opened, water flows into the piping and is discharged from all sprinklers on the piping system. Deluge systems are designed to rapidly wet down an entire area in which a fire may occur. They are suitable for various extra or special hazard situations involving possible flash fires, for example, in locations where flammable liquids or rocket propellants are handled or stored.

The importance of adequate water supplies for fire protection and sprinklers was emphasized earlier in this section.

What are several points to consider in determining the adequacy of water supplies for sprinkler systems?

The degree of fire protection provided by a sprinkler system is no better than the system's water supply. Thus, it is vital that every sprinkler system have a water supply of adequate pressure, capacity, and reliability. Both the rate of flow and total volume of water available must be able to meet any expected demands of the sprinkler system.

26. This discussion requires either a live exhibit or slides of sprinkler heads.

Operation of Sprinkler Heads: Sprinkler heads are constructed so they will open at predetermined temperatures within the range of 135° to 575°F (57.2° to 301.7°C), depending on the application requirements. Each head contains a solder link which must melt to open the individual head. Heads are also rated for use at maximum ceiling temperatures within the corresponding range of 100° to 475°F (37.8° to 246.1°C). This helps to prevent premature operation from extended exposure where elevated temperatures are normal. Sprinklers are designed to operate quickly enough to control fire and prevent its spread.



Design of Sprinkler Systems: NFPA 13, *Installation of Sprinkler Systems*, specifies the requirements for sprinkler systems, including equipment, materials, spacing, pipe sizing, hanging, valves, acceptance tests, etc.

The area of sprinkler water coverage depends on the physical characteristics of the sprinkler head (standard spray sprinkler, sidewall, extended discharge) and the water flow and pressure available to the head. NFPA 13 specifies maximum areas of coverage for sprinklers by type of occupancy. Typical spacings are 225 square feet per head for a light hazard such as a cellblock, 130 square feet per head for an ordinary hazard such as storage areas, and 90 square feet per head for extra hazard such as an auto repair shop. When placing sprinklers, it is necessary to consider the effects of obstructions such as beams, lighting fixtures, and partitions.

Sprinkler Inspection and Maintenance: Although a sprinklered facility may have contracted with a sprinkler inspection and maintenance service, and fire departments and insurance companies may make periodic inspection calls, the obligation for the care and maintenance of a sprinkler system is squarely on the shoulders of correctional officers and managers. Their lives, the lives of the inmates, and the property itself depend on sprinklers that perform as designed when needed.

What is the principal reason given by the NFPA for unsatisfactory operation of sprinkler systems? How can the problem be avoided?

The principal reason given for unsuccessful performance of sprinkler systems is water control valves that have been closed before the fire occurs or before the fire is completely extinguished. The water control valve of a sprinkler system should never be closed except when actual work is being performed on the system. Weekly inspection of the system will help to avoid this problem.

There are seven basic considerations for the inspection and maintenance of automatic sprinkler systems. They are:

1. Maintain constant water supply.
2. Keep valves open until the fire is out.
3. Limit length of time system is out of service for maintenance.

Concept: Corrections officials should know their role in inspecting and maintaining fire protection equipment and systems.

Activity:

(1) It is assumed that Level II personnel will have had some training with portable extinguishers, SCBA, and standpipe and hoses. In addition, they should have a basic understanding of equipment and systems used in their facility, e.g., hydrants, fire pumps, sprinkler systems, valves, etc.

(2) Using the checklists presented in this chapter, each group should develop an inspection and maintenance checklist, including a schedule for each procedure, that is specifically tailored to the fire protection equipment and systems used in your facility. Also, each item should specify who is responsible for carrying out the procedure. You are more interested in the items that would be checked by corrections officials rather than by a fire protection engineer, fire department official, or some local authority.

(3) The checklist should include the following areas: detection devices, alarm systems, portable extinguishers, SCBA, water supply systems, (including valves, storage tanks, and fire pumps), standpipes and hoses, sprinkler system (if the facility is sprinklered).

(4) Assign several simpler areas to one group and a more involved area to another. Much of this information students should have already gathered during their training sessions.

(5) Inform students that their work should be suitable for adoption into a comprehensive inspection and maintenance program for fire protection equipment and systems for the entire facility.

(6) Allow groups to critique and comment on each checklist. Overhead transparencies made by the students may be helpful to them in making their presentation.

28.



INSPECTION AND MAINTENANCE OF SPRINKLER SYSTEMS

Basic Considerations:

- 1.
- 2.
- 3.
- 4.
- 5.
- 6.
- 7.

Personnel Responsible for Inspecting and Maintaining Sprinkler Systems

29 This checklist can be used as the basis for a Level II student activity.

(1) Have students survey a sprinkler system either in your facility or another public building.

(2) Review the checklist with the students to determine which questions are applicable.

(3) Based on the particular sprinkler system, have groups come up with a revised checklist with more specific questions.

(4) The local fire department may be of assistance in this assignment. 29

4. Assure complete protection through coverage in all areas.
5. Avoid obstructions.
6. Protect against freezing.
7. Assure dependable operating condition of all parts.

These considerations should be reflected in any checklist devised for a facility. In order to assist you, a checklist of those components of an automatic sprinkler system that should be inspected weekly follows. The checklist is general; it is meant to serve as a guideline only. A thorough and specific list should be designed for the sprinkler system in your facility.

INSPECTION OF AUTOMATIC SPRINKLER SYSTEMS CHECKLIST

	Yes	No	Needs Maintenance (Location)
AUTOMATIC SPRINKLERS			
Do sprinklers appear to be in good condition?
Are sprinklers clean (i.e., not dirty, painted or white-washed)?
Are sprinklers free from physical damage?
WET SYSTEMS			
Have alarms been tested and are they in good condition?
Have water flow tests been performed and are the results normal?
Are cold weather valves open or closed as necessary (seasonal)?
Have anti-freeze solutions been tested and found in good condition (seasonal)?
DRY SYSTEMS			
Have alarms been tested and are they in good condition?
Is the dry-pipe valve in good condition?
Have water flow tests been performed and are the results normal?
Are the priming water level, latching arrangements, and automatic drip connections normal?
Is the temperature of the dry-pipe valve room or enclosure adequate to prevent freezing (seasonal)?
Is air supply adequate (air dryer o.k., power to compressor on)?

A thorough discussion of inspection and maintenance of sprinkler systems can be found in NFPA 13A, *Care and Maintenance of Sprinkler Systems*. This recommended practice presents detailed guidelines for the inspection and maintenance of all types of sprinkler systems.

Detection and suppression equipment available today is adequate to meet the needs of correctional facilities. Although detection and suppression will not prevent the ignition of a fire, prompt detection and suppression will assure that damage is kept to a minimum and, most importantly, that lives are not lost. Automatic sprinklers offer the greatest margin of safety for inmates. Simply, sprinklers provide the most reliable detection and suppression available today. Just as necessary, however, is equipment for manual suppression: portable extinguishers, self-contained breathing apparatus, and standpipes. Finally, consider organizing a fire brigade. The advantages for fire protection are well worth the investment.

Following is the checklist for detection and suppression activities. Be certain to examine it closely and then use the format to formulate a more extensive checklist suited to the needs of your facility. Also, you may want to incorporate some or all of the items from the checklists on portable extinguishers, standpipes, and, if your facility has them, automatic sprinklers.

CHECKLIST

YES	NO	DON'T KNOW	
.....	1. Are portable fire extinguishers of the proper type and number available?
.....	2. Is your facility protected by a complete heat detection or smoke detection system?
.....	3. Is your facility protected by a complete automatic sprinkler system?
.....	4. Are detection and/or sprinkler systems tested on a regular basis?
.....	5. Is the fire detection and/or sprinkler system alarm connected directly to the local fire department?
.....	6. Are fire hose stations for use by correctional officers provided and readily accessible?
.....	7. Have all personnel been trained in the proper use of all fire protection and fire extinguishing equipment?

- 8. Has the fire brigade (either staff or inmates) been provided with the proper fire fighting equipment and training?
- 9. Can security be maintained while fire fighting operations are in progress?
- 10. Are there means to stretch fire hoses through double security gates (sallyports) so that the gates can be closed and security maintained?

Now, let's review the information on detection and suppression activities.

CHAPTER REVIEW 30

30. Follow the instructions specified for the Chapter Review of Chapter One

- 1. Define detection and suppression activities.
 - _____
 - _____
 - _____
- 2. List the three stages of detection and suppression.
 - a. _____
 - b. _____
 - c. _____
- 3. Which of the following are methods of control related to the goal of detection and suppression activities?
 - a. Provide evacuation to secure area of refuge.
 - b. Provide reliable suppression.
 - c. Provide reliable early warning detection.
 - d. Provide reliable alarm systems.
 - e. Provide fire brigade training.
- 4. Compared to automatic systems, the principal shortcoming of manual systems is:
 - a. proper equipment.
 - b. inability to completely extinguish a fire.
 - c. time.
- 5. Explain briefly why automatic detection and suppression systems are superior to manual systems. (Refer to Fig. 6.1.)
 - _____
 - _____
 - _____
 - _____
- 6. Which of the following fire safety objectives are better met by using automatic systems?
 - a. life safety
 - b. property protection
 - c. limited downtime
 - d. security

7. List three reasons why vandalism is not a significant problem in correctional facilities with automatic sprinkler systems.
- a.
- b.
- c.
8. Which type of detection and alarm system provides occupants with a greater margin of safety for evacuation?
- a. manual
- b. automatic
9. Name the three basic types of fire detecting devices.
- a.
- b.
- c.
10. Which fire detector would you chose for the following hazards?
- a. Smoldering conditions
-
- b. Rapidly developing flaming conditions (e.g., flammable liquid fires)
-
11. List two important functions served by alarm systems.
- a.
-
- b.
-
12. What basic problem do evacuation alarms in institutions such as correctional facilities present?
-
-
13. List five examples of fire protection available for suppression activities.
- a.
- b.
- c.
- d.
- e.
14. List three of six criteria used for selecting appropriate portable extinguishers.
- a.
- b.
- c.
15. Match the class of fire in column A with its appropriate description in column B.
- | | | |
|-------|---|--|
| | A | |
| | a. Class A | |
| | b. Class B | |
| | c. Class C | |
| | d. Class D | |
| | B | |
| | 1. Fires involving energized electrical equipment. | |
| | 2. Fires involving combustible metals such as magnesium, titanium, and others. | |
| | 3. Fires involving flammable and combustible liquids, e.g., oils, greases, oil-base paints, lacquers. | |
| | 4. Fires involving common combustible materials such as wood, cloth, paper. | |

16. On what type of fires would a portable extinguisher rated 4-A be used? How would this extinguisher compare to one rated 20-A?

.....

17. On what type of fires would an extinguisher rated 5-B:C be used?

.....

18. List one disadvantage of water-based portable extinguishers.

.....

19. Locations for portable extinguishers should be selected that will (you may check more than one):

- a. Provide uniform distribution.
- b. Provide easy accessibility.
- c. Be relatively free from blocking by storage and equipment.
- d. Be near normal path of travel.
- e. Be free from potential of physical damage.
- f. Be readily visible.

20. OSHA regulations require that (check appropriate statements):

- a. Portable extinguishers with a gross weight exceeding 40 lbs be mounted so that the top of the unit is not more than three and one-half feet above the floor.
- b. Portable extinguishers with a gross weight of 40 lbs or less be mounted so that the top of the unit is not more

than five feet above the floor.

- c. The bottom of all portable extinguishers be mounted a minimum of four inches off the floor.

21. Check the type of self-contained breathing apparatus (SCBA) most often found in correctional facilities.

..... closed-circuit type with canister and breathing bag

..... open-circuit "demand" or "pressure demand"

..... closed-circuit oxygen rebreathing system

22. Identify the principal components of a water distribution system on the diagram below.

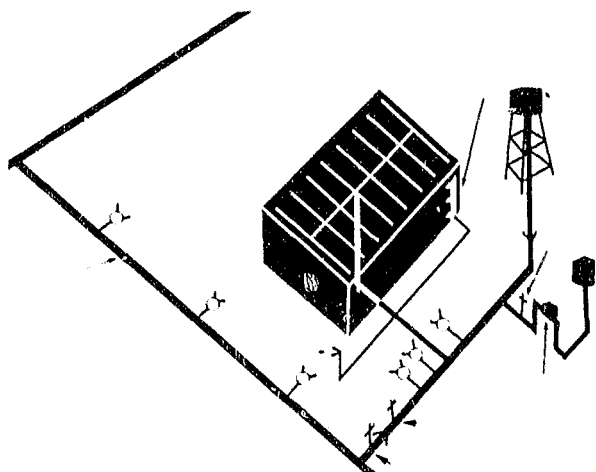

23. Match the class of standpipe listed in column A with its principal users listed in column B.

A

- a. Class I
- b. Class II
- c. Class III

B

- 1. Provided for use by fire department and those trained in handling heavy hose streams.

2. Provided for use by building occupants.
3. Provided for use by either fire department and those trained in heavy hose streams, or by building occupants.
24. A dry standpipe system:
- _____ a. has a permanent water supply.
- _____ b. has no permanent water supply.
25. Match the following:
- _____ a. Dry barrel hydrant
- _____ b. Wet barrel hydrant
1. Used when weather conditions are such that there is no danger of freezing. (Also called California type.)
2. Used whenever there is a chance of freezing.
26. The principal reason for unsatisfactory performance of sprinklers is:
- _____ a. inadequate partial protection.
- _____ b. faulty design.
- _____ c. water control valves shut off.
27. Briefly discuss the value of sprinkler protection.
- _____
- _____
- _____
- _____
28. The primary method of extinguishment by sprinklers is:
- _____ a. cooling and quenching burning material.
- _____ b. smothering the burning material.
- _____ c. removing the fuel.
29. List the four basic types of sprinkler systems.
- a. _____
- b. _____
- c. _____
- d. _____
30. A wet-pipe system is used primarily:
- _____ a. in unheated rooms or buildings where there is danger of freezing.
- _____ b. in heated areas where there is no danger of freezing.
- _____ c. for special hazard situations involving possible flash fires.
31. An automatic sprinkler system detects the presence of fire, triggers an alarm, begins suppression:
- _____ a. simultaneously
- _____ b. sequentially
32. Sprinkler heads are rated according to:
- _____ a. application requirements
- _____ b. maximum ceiling temperatures
- _____ c. each of the above
33. List five of the seven basic considerations of inspection and maintenance of automatic sprinkler systems.
- a. _____
- b. _____
- c. _____
- d. _____
- e. _____

**PLANNING
AND
TRAINING
OPERATIONS**

1. Provide staff education and training
2. Provide inmate education
3. Plan emergency procedures

Chapter Seven

THE FIFTH GOAL: PLANNING AND TRAINING OPERATIONS

OVERVIEW

1. This chapter offers the greatest opportunity for both Level I and Level II students to work on projects (without any expenditures) that will directly affect fire safety at their facility. Before beginning this chapter, obtain copies of any emergency plans for your facility. You are more likely to have a riot procedure in existence than a fire safety evacuation plan or procedure.

As the last goal of the Simplified Fire Safety System for Correctional Facilities, planning and training operations is no less important than any other goal. Planning and training operations involve thought, analysis, imagination, and judgment. They are the responsibilities of management who must systematically organize all efforts in carrying out any decisions related to planning and training. These operations require an allocation of resources, especially human resources.

In discussing planning and training operations, this chapter presents reliability factors, case histories of failure, methods for control, and available technology.

After reading this chapter and completing the exercises as directed, you will be able to do the following:

- Define planning and training operations.
- List three methods for achieving planning and training operations.
- Name two correctional facility fires in which planning and training operations failed.
- Identify those members of the corrections community who should be involved in educational programs appropriate for their respective training.
- Identify five characteristics of an effective emergency operating plan.
- List five steps involved in preparing an emergency operating plan.
- Explain any impact the inmates' rights issue may have on methods for achieving planning and training operations.

Before beginning this chapter, you may want to use the glossary to review any of the following terms with which you are not familiar.

emergency operating procedures
fire brigade
software

Planning and training operations constitute the concept of planning emergency operating procedures and conducting training activities. Planning and training promotes more efficient implementation of the other goals of the Simplified Fire Safety System, thereby giving them a much greater chance for success.

Planning and training will not, however, work alone. Two case histories illustrate this point. Although lack of planning and training operations contributed to the five deaths at the Federal Correctional Institution at Danbury, Connecticut, at the St. John, New Brunswick facility, planning and training took place, yet twenty-one inmates still died.

What other goal of the Simplified Fire Safety System at St. John and Danbury failed so significantly that planning and training operations had little effect?

In both of these fires, the type and quantity of fuel was so deadly that manual suppression could not offset the fuel overload. To assume that planning and training operations will provide a fire safe environment and eliminate the potential risk of fire is to court disaster. Efficient planning and effective training programs, however, can help make a marginal fire safety system effective. When fire defenses are basically weak, these two factors can help reduce the impact of a potentially disastrous fire.

How can planning and training help reduce fire's impact when fire defenses are weak?

2.



PLANNING AND TRAINING OPERATIONS

Definition
Case Histories of Failure
Methods

- 1.
 - 2.
 - 3.
- Reasons for Cost Effectiveness

2

DEFINITION

RELIABILITY

Planning and training can offer some assurance that personnel, especially those involved in fighting the fire and evacuating inmates, will perform their duties effectively and will not panic under emergency conditions. Also, by maintaining control of the situation, the occupants are less likely to panic. In this way the effect of the unreliable human factor is minimized.

Planning and training operations do not usually require a substantial capital investment. But a commitment to a systematic effort toward certain decisions that meet the needs dictated by the fire safety objectives is required. In fact, planning and training operations can be an extremely cost-beneficial method of assuring that the other system goals will reach stated objectives — life safety in particular, but also property protection, security, and limited downtime. This cost-effective factor is illustrated by the following examples.

First, automatic detection and alarm systems provide a greater margin of safety for evacuation of building occupants. If evacuation procedures were included in planning operations and fire drills were conducted as part of training operations, the margin of safety would be extended, thus increasing the reliability of detection and suppression activities.

Second, planning and training are particularly important for maintaining a high level of security during a fire. For example, both gates of a sallyport (security vestibule) cannot be shut at the same time if a fire hose is stretched through them to a fire area. Proper planning ahead of time can provide either a cut-out in the gate to accommodate a fire hose or permanent piping through the sallyport, allowing both gates to be closed and security to be maintained.

METHODS OF CONTROL

The methods for achieving planning and training operations are: provide staff education and training; provide inmate education; and plan emergency procedures. These methods emphasize that planning and training operations can help to make a marginal fire safety system effective, usually without a major fiscal commitment.

AVAILABLE SOFTWARE

Previous chapters discussed the technology that is available to help achieve each goal. Most of this technology involves equipment or hardware, for example, locking systems and sprinklers. For planning and training operations, however, it is more appropriate to talk about software. For a correctional facility, fire protection software refers to educational or training programs and emergency operating procedures.

One feature of most software is its relatively low cost of implementation. Most educational and training programs require lit-

tle capital investment, especially since much of the expertise for training both staff and inmates may already exist in-house. Moreover, audiovisual presentations on fire-related subjects, such as how to use portable extinguishers, are readily obtainable and relatively inexpensive. Time and an organized approach are the costs of developing successful educational and training programs and emergency operating procedures.

In your facility, who should have education and training in fire safe behavior and practices?

There are three groups of personnel who require education and training related to fire safety: staff, including management, inmates, and the facility fire brigade.

All staff and inmates should be involved in a fire safety program. Fire safe behavior is everyone's concern. Not only does fire safe behavior help to minimize the number of fire incidents, but it also helps to reduce the potential for large-scale property and life losses should a fire occur. The usual victims of fire, the inmates, may be highly motivated to learn basic facts related to fire hazards and their ability to protect themselves during a fire emergency. Staff members will increase their ability to maintain security, safeguard lives, and protect property during a fire if they are given proper information and drilled in its use.

To maximize effectiveness, fire safety programs must be tailored to the individual facility. The size and age of the buildings, the security classification of the facility and its proximity to municipal fire departments are only some of the variables that must be carefully considered in developing programs. There are also two problems in implementing fire safety programs that all facilities should recognize initially: (1) the operational limitations created by participants who require restriction and routine, and (2) the financial limitations of facilities which normally operate on public funds. To offset these limitations, it is important to keep in mind the motivation provided by the instinct of self-preservation and the motivation initiated by the legal implications of inmates' rights.

Although fire safety programs for staff personnel will vary from facility to facility, certain aspects should be common to all comprehensive educational and training programs.

EDUCATIONAL AND TRAINING PROGRAMS

3

Program Participants

3.

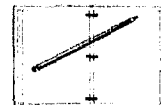

EDUCATIONAL AND TRAINING PROGRAMS
 Problems
 Variables in Developing Programs
 Staff Programs
 Inmate Programs

The content of this discussion is aimed primarily at the Level I student who will be responsible for establishing and implementing training programs. However, the Level II student may have valuable suggestions about what both staff and inmates regard as potential areas for training.

Staff Programs

- History of the problem. Any type of program is designed to solve a particular problem or fill a specific need. A short description of the background and evolution of the problem serves to put the educational and training process in perspective. It also helps to motivate staff personnel and gets them involved in the education and training process. These were the objectives of the first chapter in this manual.
- Hazards of fire. Understanding what contributes to a fire hazard, for example, improper storage of flammable and combustible liquids and overloaded electrical circuits, provides an overview of the fire problem in a correctional facility. Included in this aspect of a fire safety program would be the prevention and reduction of fire hazards.
- Available fire protection technology. A fire safety program has to provide a basic familiarity with the fire protection technology available for application in correctional facilities. Then education and training becomes specific to the available technology at the particular facility. This includes: hands-on training where necessary (portable fire extinguishers), location, operation, and maintenance of various systems (sprinkler systems, standpipe and hose systems), and equipment (hydrants, fire pumps).
- Emergency operating procedures. This includes evacuation plans and responsibilities of staff and fire brigade (for example, operation of standpipes and hoses, and notification of the fire department). Emergency operating procedures will be discussed in more detail later in this section.
- Potential problems related to a particular facility. Each facility has its own unique problems that impact on fire safety, for example, type of building construction, interior finish, type of fuel, and number of inmates in cells or cellblock areas. These potential problems must be identified so that there will be no surprises during a fire emergency.

There are any number of prepackaged programs available from audiovisual producers and distributors such as the Matthew M. Brady Co., Bowie, Maryland; the National Fire Protection Association, Boston, Massachusetts; and the Factory Mutual System, Norwood, Massachusetts. These programs cover a wide range of information on fire safe behavior and procedures, including sprinkler systems, the chemistry of fire, and how to organize fire brigades. However, their use in a comprehensive educational and training program must be supplemented with information that is specific to each facility.

Inmates should be included in educational programs for fire safety on a select basis. If any training is included, it should not disturb a routine too dramatically. Many of the topics that would be presented in programs addressed to staff personnel are also relevant to inmates. These include selected case studies discussing the history of the problem, hazards of fire, and emergency operating procedures, especially fire drills. It is possible to carry out fire drills in a correctional facility if they are slowly and carefully introduced into the routine. Although a security breach may seem possible, it will be at least, if not more, likely during an actual emergency. It is always possible to provide extra security during a preplanned fire drill. Although they require time and effort, drills may prevent a panic situation during an emergency.

Also relevant to the educational and training needs of inmates are personal actions or safeguards during an emergency. Inmates should know how to protect themselves while waiting for evacuation orders. Specifically, inmates should know how to: call for help at the first signs of fire or smoke; seal off doorways having solid doors by blocking them with bed linen; vent smoke from a room with windows to the outside by opening them slightly at the top and bottom; and stay low to the floor where the air is least contaminated with smoke and toxic gases.

Most fires begin in or near inmate living quarters (cells and cellblocks) which contain the greatest amount of synthetic combustibles, for example, mattresses and other furnishings, and interior finish. Since these combustibles produce heavy concentrations of smoke and toxic gases, self-contained breathing apparatus may provide staff with a necessary margin of safety to evacuate inmates.

Another group that requires training is the facility fire brigade. For many correctional facilities, as well as other institutions, fire protection is relinquished to the public fire department. However, correctional facilities present a unique complication — they are designed for security, which means that accessibility to the fire area could be difficult. In addition, because the local fire department is usually prepared and equipped to provide protection for the common hazards in the surrounding community, the needs of a large facility may overwhelm it. Finally, if the facility is located some distance from the nearest fire department, the considerable response time required may jeopardize rescue.

Responsibilities of the Brigade: Reasons such as those just discussed should cause you and others in your facility who make decisions concerning fire-related matters to consider organizing a fire brigade. The responsibilities and functions of a fire brigade or facility emergency team will vary with the size of the facility and the size and location of the nearest fire department. The respon-

4 **Fire Brigades**

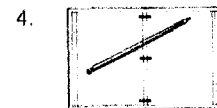

EDUCATIONAL AND TRAINING PROGRAMS
Fire Brigades
Rationale for having a brigade
Responsibilities of Brigade
Training of Brigade

sibilities may include calling the fire department, safeguarding lives, providing manual suppression to control the fire until the fire department arrives, and protecting equipment. These responsibilities, however, can be carried out only if the brigade is properly organized, trained, and equipped.

In its simplest form the fire brigade organization consists of the manager of the facility assisted by selected personnel. Fire brigade members are often trustees and/or staff members with an interest in fire protection. It is usually best to select volunteers
5 who will take an interest in fire brigade activities. In large facilities, personnel should be organized into separate fire fighting teams assigned to predetermined areas. The availability of fire fighting assistance from a public or private fire department may affect the nature of the fire brigade organization.

5. This section on fire brigades can be considered motivational as well as educational. It is from these students — primarily Level II personnel — that your facility will make up its fire brigade. If personnel realize that there is a genuine need for a fire brigade and that it is to their advantage to support and join one, then your facility should have little trouble obtaining volunteers for it.

Brigade Training: A schedule of training should be established for members of the brigade. Members should be required to complete a specified program of instruction as a condition of membership in the brigade. Training sessions should be held at least monthly. Members of the brigade should be instructed in the handling of any and all fire and rescue apparatus provided. Training should include fire fighting with portable extinguishers, using hose lines, venting of buildings, and performing related rescue operations.

Assistance in setting up and training the fire brigade can be obtained from outside agencies. Among these are municipal fire departments, state fire schools, state fire marshals' offices, and any other agency where fire service training is given. Further guidance on organizing and training can be obtained from NFPA 27, *Private Fire Brigades*, and the NFPA *Industrial Fire Brigade Training Manual*.

Brigade Equipment: The brigade should be provided with a variety of equipment and enough tools to enable it to perform the service for which it was organized. It is the responsibility of management to see that this equipment is provided. The following is a list of some of the principal categories of equipment that should be considered.

- Portable fire extinguishers.
- Hose and hose accessories, including hydrant wrenches, hydrant valves, rope tools or hose straps, rope, combination shutoff nozzles, gated wyes, double female hose couplings, and hose spanners.
- Portable lighting equipment, including portable electric generators, hand lanterns, and a supply of extra batteries.
- Forcible entry tools, including axes, saws, plaster hooks and pike poles, claw tools, door openers, and crowbars.

- Ladders, consisting of a selection of sufficient length for the work required.
- Salvage equipment, including salvage covers, brooms, and squeegees.
- Rescue and first-aid equipment. The exact equipment provided should be governed by the extent to which members of the brigade have been trained in its use. It may include first-aid kits and resuscitation equipment — inhalator, resuscitator, or modification of these devices with spare cylinders of air or oxygen where needed.
- Spare and replacement equipment. This category includes those items which may require periodic replacement, and may include fusible links for fire doors, automatic sprinkler heads, and extinguisher seals.
- Personal protective equipment, including helmets, coats, gloves, and rubber boots. Rope tools and self-contained breathing apparatus (SCBA) may be included, depending on the extent to which members are trained in their safe and effective use.
- Vehicles. Depending on the size and responsibility of the fire brigade, the need for emergency vehicles will vary. It may range from a simple push cart containing emergency equipment to a full-size fire truck. (see NFPA 19, *Automotive Fire Apparatus*).

The organization, training, and equipping of a fire brigade, unlike programs for staff and inmates, require a certain capital investment (depending on the size and extent of the brigade). A properly trained and equipped brigade, however, may mean the difference between a minor fire emergency and life and death. Moreover, it is the obligation of every facility to be able to defend itself; a fire brigade helps fulfill that need.

One of the most effective means your correctional facility has for preventing a fire disaster is an emergency operating plan or procedure. Instruction in such a procedure should be incorporated into any educational and training fire safety program since it involves staff personnel, inmates, and the fire brigade, all working together on planning for an emergency. The ability of any facility to minimize the risks to life and property during a fire emergency depends on the extent of preparation beforehand.

The purpose of an emergency operating plan is to provide a guide for evaluating the particular problems at hand and for coordinating the response of the fire brigade and fire department as well as the action of staff and inmates.

An effective emergency operating plan has certain characteristics.

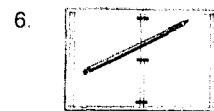

EMERGENCY OPERATING PROCEDURES

Purpose
Characteristics
Steps in preparing an emergency operating procedure.

6 **EMERGENCY OPERATING PROCEDURES**

Purpose

Characteristics

- *Simple.* Although all roles, responsibilities, and contingencies should be clearly defined in a plan, too much detail can hinder flexibility.
- *Comprehensive.* An emergency operating plan should include provisions for all circumstances that can be reasonably anticipated. The plan should define the roles of all personnel and equipment who might be involved both within and outside the facility.
- *Specific.* A plan should be uniquely tailored to the needs, resources, and capabilities of the individual facility. Also, a plan should address the different amounts of personnel and equipment that are demanded by the various stages of response.
- *Flexible.* A plan should be flexible enough so that procedures can be adapted to any unusual circumstances as well as probable emergencies.
- *Workable.* A plan should relate to everyday operations of the facility. To maintain this workability, a plan should be updated or revised periodically.

The development of an emergency operating plan is not an easy task. But any plan should be carefully evaluated according to the characteristics discussed above. Your facility may already have contingency plans for other emergencies which can be modified to include fire emergencies.

Planning Team

The responsibility for preparing an emergency operating plan should be delegated to a task force or team. Ideally, such a team will consist of representatives from management (for example, the warden or assistant warden), staff, inmates, and fire brigade members. The task force or team should also receive advice or assistance from representatives of the local fire department and law enforcement agency. Ambulance and rescue services as well as the state police might also be included in this group.

7. Although it is important for both Level I and Level II personnel to understand the need for, and to be aware of, the basic principles involved in planning, most of the responsibility for designing and implementing plans will be in the hands of supervisory personnel. Thus, tailor your discussion accordingly.

Success in preparing the plan is dependent upon coordinating the efforts of all involved. A useful approach is to appoint project coordinators whose responsibility it is to decide what needs to be done, who will do it, where and how it will be done, and when the various assignments will be completed. As in any major undertaking, a planning schedule will help to facilitate the process by providing checkpoints for completion of subtasks.

Preparation of the Plan

8. Preparing an effective emergency operating plan can be accomplished in five steps.

1. Define the potential fire protection problems in the particular correctional facility.

Name several potential fire protection problems in your correctional facility.

Potential problems will, of course, vary from facility to facility. Specific problems, many of which have been mentioned previously, include the location and type of hazards (for example, flammable liquids storage rooms and padded cells), type and arrangement of combustible materials in cells and cellblock areas (for example, mattresses and other furnishings or interior finishes), and other variables such as age of buildings and type of construction. It is also necessary to weigh the effect of the security issue on any potential problem.

2. Set objectives for the plan — that is, what you can expect the plan and portions of it to do for the facility in an emergency. A specific objective for an emergency plan may be to evacuate a number of cellblock areas within two minutes of the alarm with no breach of security. Another objective may be to notify the fire department within twenty seconds of discovering ignition. Notification of the fire department should be confirmed even if the alarm system notifies it automatically.

3. Determine the facility's capability for controlling an emergency situation. Identifying and assessing potential problems help to define the specific resources needed to control a fire emergency in a facility. In order to determine which control actions are possible for a specific situation, it is necessary to inventory the fire protection resources available to the facility in terms of amount and condition of suppression equipment, fire department response, personnel, size and capabilities of a fire brigade, sprinkler systems, self-contained breathing apparatus, and any other available emergency assistance.

4. Define the roles of the responding agencies, especially the fire department and the fire brigade. Included in this fourth step is assigning the responsibility for notifying the fire department. It is also necessary to establish the role of a liaison between the fire department and fire brigade and to assign who has the overall responsibility for the operations at the facility. The responsibility for clean-up, salvage, and restoration of fire protection systems should be clearly specified, but will probably be the job of the fire brigade.

5. Put the information into written form. When the preparation and information-gathering tasks of the plan have been com-

8.



LEVELS I AND II

Preparing an emergency operating procedure.

Concept: The staff of a correctional facility represents the most qualified group for preparing an emergency operating procedure.

Activity:

(1) Divide class into groups.

(2) Assign each group the task of preparing an emergency procedure for a different location of the facility, e.g., sleeping areas (cellblocks), dining hall, recreational room. The areas should be chosen because of their high hazard probability — either from accidental or deliberate ignition.

(3) Have each group complete preliminary steps 1-4 in preparing plan according to those outlined on the previous pages of text.

(4) After completing steps 1-4, have each group write an emergency procedure for its assigned location. The procedure should be set up according to a priority of actions to be taken.

Considerations would include:

a. Notification of fire department emergency medical personnel, and outside law enforcement agencies.

b. Evacuation procedures.

c. Personnel call list.

d. Use of available fire protection equipment.

e. Role of fire brigade.

f. Establishment of alternative command center.

g. Chain of command.

h. Responsibilities of involved personnel.

i. Means of updating and revising plan.

j. Format for fire drills to test plan.

k. Role of fire department and provisions for its security.

l. Communications, both internal and external.

(5) When plans have been completed, arrange for members of fire department to review plans and determine feasibility for fire fighting operations.

9. Make some of these existing plans available for students to examine in order to make formulation of their plans easier.

10.



LEVEL I

Concept: Supervisory personnel should be able to suggest practical, cost-effective ideas and suggestions for implementing educational and training programs and emergency operating procedures.

Existing Emergency Plans

Activity:

(1) Assign one method or software "technology" to each group. Each group will prepare to defend a position related to their assigned method. The defense will be based on any workable ideas they have formulated for implementing the position.

(2) Sample Position:

- Staff training: Staff training is the most critical element of an effective fire safety system.
- Inmate education: A thorough inmate education program can be incorporated into the fire safety system without compromising security or operational procedures.
- Fire drills: Fire drills can and must occur on a frequent basis.
- Fire brigade: An inmate or staff fire brigade is a viable resource for any institution.
- Emergency operating procedures: A pre-fire plan should be developed with the active participation of all available outside resources.

(3) Each group will have a specific time period, e.g., ten minutes, to prepare defense of position related to assigned method.

(4) In addition, each group will be responsible for questioning other positions using a number of key questions.

Key Questions:

- Who should be involved?
- In what function?
- Can the element be inserted into existing programs or operational procedures?
- What resources can be tapped?
- What innovative policies can be generated?
- What questions will be asked?

pleted, the information will have to be organized, tested, written into a formal document, reviewed, and distributed. How the information for the plan is organized depends upon what is most beneficial to the facility. Although the plan may be arranged in a number of ways, it is important to consider: the particular problems and hazards involved; the possible locations for an incident; and the roles and responsibilities of responding personnel. Proper organization and evaluation of the written plan will assure that the response is neither too great nor too small for the emergency at hand.

It is helpful to look at general emergency plans that have already been developed by individual correctional facilities.

- 9 Although such plans address problems that are specific to the particular facilities, they can still be useful as guides in developing plans for your facility.

The most effective emergency operating plans are contained within a comprehensive educational and training fire safety program. The Ohio State Reformatory in Mansfield, Ohio, for example, has a five-part fire safety program that includes preplanning fireground operations and establishing a working relationship with local fire departments, as well as preventing and reducing fire hazards, developing and upgrading fire fighting systems and protective equipment, and staff training.

Two other successful training programs are those developed by the Dallas jails (local and county) and by the Los Angeles County Jail. There are, of course, others. However, the first step in any fire safety program is making the commitment to planning and training: that is, an allocation of resources in terms of both financial and time commitments from management, and the involvement of all staff. Inmates must be made to realize that fire safety programs may benefit them the most and require some participation by them.

Remember, planning and training by themselves will not provide a fire safe environment. However, planning and training can be an extremely cost-beneficial method for increasing the reliability of the other system goals in reaching the fire safety objectives.

- 10 Further, if fire defenses are basically weak, planning and training can help reduce the impact of a potentially disastrous fire.

These questions will also help in preparing defense of position.

(5) Each group will have five minutes to report their defense and five minutes to answer questions from the other groups. Remaining groups listen to and record ideas and suggestions made by the presenting group.

Following is the last part of the fire safety checklist for correctional facilities that we began in Chapter Three. The completed checklist provides a guideline for evaluating the goals of the Simplified Fire Safety System.

CHECKLIST

YES	NO	DON'T KNOW	
_____	_____	_____	1. Does each building have a written fire emergency plan detailing staff action during a fire emergency?
_____	_____	_____	2. Does each shift practice the fire emergency plan at least quarterly?
_____	_____	_____	3. Are new employees briefed on the fire emergency plan?
_____	_____	_____	4. After each practiced fire emergency drill, is a critique performed in order to evaluate and update the fire emergency plan?
_____	_____	_____	5. Does your emergency plan provide for reliable release of inmates to a secure yard or other area in case of fire?
_____	_____	_____	6. Is there a reliable method of notifying corrections officers that a fire emergency is in progress?
_____	_____	_____	7. Have inmates been instructed in emergency procedures in case of fire?
_____	_____	_____	8. Have inmates been given fire safety briefings?
_____	_____	_____	9. Has the local fire department been involved in the formulation of your fire emergency plan?
_____	_____	_____	10. Has the local fire department been briefed on building conditions, contents, and fire fighting facilities within the complex?
_____	_____	_____	11. Have you provided the opportunity for and assisted the local fire department in the prefire planning of the facility?
_____	_____	_____	12. Is the fire department the first to be notified in the event of a fire emergency?

Now, let's review.



11.

LEVEL II

Concept: Corrections officials should be able to make a judgment on the most critical fire hazards and problems in their facility and suggest means of correcting them. This activity should synthesize the information learned from completing the checklist.

Activity:

(1) Explain to students that they are to look upon this activity as if they are members of a task force or planning team.

(2) Using the list or lists of problem areas students have developed in previous group discussions (e.g. those that were used in completing the checklist), each student should list the ten hazards or problem areas in their facility which they consider to be most critical and in need of immediate correction.

(3) From this list of ten problem areas, each group is to arrive at a consensus of the five most critical problem areas.

(4) Using this list of five areas each group should identify one or two specific methods for correcting each problem area.

(5) As each group spokesperson reads the group's report, copy the information on the chalkboard.

(6) When all groups have reported, ask for a class consensus of the five most critical problem areas (chosen from all group lists) and the best method for achieving a solution to each problem.

CHAPTER REVIEW

12 Follow the instructions specified for the Chapter Review in Chapter One.

1. Define the concept of planning and training operations.

2. Which case history best illustrates the disastrous results of the lack of planning and training operations?
 - _____ a. Oregon State Penitentiary
 - _____ b. Federal Correctional Institution at Danbury
 - _____ c. Saint John City Detention Center
3. Which of the following is/are true of planning and training operations?
 - _____ a. Help make a marginal fire safety system more effective.
 - _____ b. Minimize effect of unreliable human factors.
 - _____ c. Can provide a fire safe environment.
 - _____ d. Extremely cost-beneficial method of increasing reliability of other system goals.
4. Which of the objectives of the Simplified Fire Safety System do planning and training operations help reach?

5. Methods for achieving planning and training operations are:
 - _____ a. Provide staff education and training.
 - _____ b. Provide for communication with local fire department.
 - _____ c. Provide inmate education.
 - _____ d. Practice fire drills.
 - _____ e. Train fire brigade.
 - _____ f. Provide for means of egress.
 - _____ g. Plan emergency procedures.
6. Which groups of people in correctional facilities require education and training in fire safety programs? (check one)
 - _____ a. staff
 - _____ b. inmates
 - _____ c. both staff and inmates
7. How is the effectiveness of a fire safety program for a facility maximized?

8. Critical problems for all facilities in developing fire safety programs are:
 - _____ a. Maintaining security during a fire emergency.
 - _____ b. Lack of sprinkler protection.
 - _____ c. Poor communication between fire departments and brigades.
 - _____ d. Financial limitations.
9. List five aspects common to all comprehensive educational and training programs.
 - a. _____
 - b. _____
 - c. _____

- d. _____
- e. _____
10. Which of the following are necessary parts of a fire safety program for inmates?
- _____ a. Sprinkler maintenance.
- _____ b. Fire drills.
- _____ c. Use of portable extinguishers.
- _____ d. Use of standpipes and hoses.
- _____ e. Use of self-contained breathing apparatus.
- _____ f. Rescue operations.
- _____ g. Personal actions during an emergency.
11. List four responsibilities of a fire brigade.
- a. _____
- b. _____
- c. _____
- d. _____
12. List four aspects that should be included as part of the training of a fire brigade.
- a. _____
- b. _____
- c. _____
- d. _____
13. State briefly the purpose of an emergency operating plan.
- _____
- _____
14. What are the five characteristics of an effective emergency operating plan?
- a. _____
- b. _____
- c. _____
- d. _____
- e. _____
15. List the individuals you would want to have on a task force whose responsibility it is to develop an emergency operating plan for your correctional facility.
- _____
- _____
- _____
16. Name the five steps in preparing an emergency plan.
- Step 1: _____
- Step 2: _____
- Step 3: _____
- Step 4: _____
- Step 5: _____

Chapter Eight

DEVELOPING A PLAN USING THE SIMPLIFIED SYSTEM

OVERVIEW

1. This chapter is directed towards Level I personnel. Although selected Level II personnel should be involved in a planning team or task force, the basic function of planning is a management tool. Inform students that they will be working on developing a comprehensive fire safety plan for their facility.

The first seven chapters of this book have provided readers with the knowledge and information needed to improve fire safety in their respective facilities. In this chapter, readers are asked to apply the knowledge gained in preparing a comprehensive fire safety plan. The chapter presents guidelines to accomplish this assignment. It pulls together all of the information related to the Simplified Fire Safety System, considers cost alternatives, and asks the reader to make a commitment to translate the information into a viable plan. The chapter also addresses types and sources of financial and technical assistance.

After reading this chapter and completing the exercises as directed by the text, you will be able to do the following:

- Outline a comprehensive plan to improve the level of fire safety at your facility using the Simplified Fire Safety System.
- Compare the costs and fire safety impact of the various alternatives of your plans.
- List five areas and two sources of technical assistance.
- Describe three types of financial assistance.

PLANNING AS A TOOL OF MANAGEMENT

Planning is a basic function of management. Within the broad area of planning are the specific tasks of formulating objectives, devising a strategy for achieving the objectives, setting up the operations, and allocating the resources to achieve the objectives.

Planning determines what demands will be made upon the resources and orders the priorities of the various operations needed to achieve the objectives. Planning helps management chart a course today to meet tomorrow's goals, thereby giving management some assurance that the future it anticipates will become reality.

Effective planning includes short- and long-range goals. Short-range goals and decisions must be built into long-range planning. Without the guideposts of the short-range goals, the long-range goals will be difficult to accomplish.

Although both short- and long-range planning require strategic decisions, the effects of short-range planning are felt more immediately and usually require little or no financial support. Long-range planning generally requires major allocations of resources: manpower, money, materials, machinery, and time. Fire safe building construction, installation of automatic sprinklers, and the purchase of major apparatus may be some of the items considered in long-range fire protection planning. On the other hand, short-range planning might include development of an emergency operating plan, inspection procedures, the purchase of portable extinguishers or SCBA's, and staff and inmate education and training programs.

Planning begins with the objectives, for it is the objectives that quantify the purpose or mission of a plan. In order to do this effectively, objectives must:

- provide standards against which performance is to be measured;
- be capable of converting operations into specific targets and assignments;
- allow the concentration of key resources into a selective effort.

If the purpose of planning is to help management anticipate the future, then objectives are the means by which the future is defined. Objectives provide motivation for work and achievement. On the negative side, they emphasize deficiencies when one has fallen short. Objectives are meant to improve organization and efficiency and assist in the operation of planning. Properly written they:

- provide a specific course for the plan to follow;
- force the setting of priorities;
- force one to make commitments;
- define reality and separate it from wishful thinking;
- serve as criteria to sharpen decision making.

- 2 2. Ask students what decisions, items, or allocations they would include in long-range planning and which they would include in short-range planning. Note suggestions on a chalkboard or overhead. Students should have an understanding of what is usually included in long- and short-range planning.

THE ROLE OF OBJECTIVES

3

3.

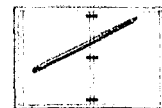

FIRE SAFETY OBJECTIVES
Importance of Objectives
Factors Affecting Reliability
Guidelines for Establishing
Objectives

This last point is especially important since decisions should be made in regard to some criteria or standards. If standards have not been defined, decisions will still be made, but they will be made in terms of immediate pressures: for example, acting in a manner that is not cost-effective in response to some disaster, court order, or emotional requirement.

Specific objectives must be set for each area. For example, the requirements to attain the overall objective "produce a fire safe environment" may be understood but, as written, it is not specific enough to allow for detailed implementation or evaluation. An objective must state precisely what outcome is desired and what criteria are necessary to attain satisfactory performance. When they are so stated, objectives will themselves provide the standards for evaluation.

FIRE SAFETY OBJECTIVES

Up to this point the discussion has centered around planning as a function of management and the role objectives play in the planning process. Now, the discussion will focus on fire safety objectives for correctional facilities. This discussion will be general since it is assumed that a fire protection engineer will be involved in the early phases of planning, especially in setting the objectives. As you will recall, fire safety objectives for correctional facilities are established in four areas.

What are these four areas?

The four areas are life safety, property protection, downtime, and security. Life safety relates to the protection of individuals from death or injury. Property protection includes protecting both the facilities themselves and their contents. Downtime indicates an interruption in the continuity of operations and is comparable to the insurance term "business interruption." Limited downtime means keeping the loss of use of a facility or any portion of it to a minimum. Security refers to the maintenance of fire safety without jeopardizing the loss of inmates through escape, suicide, murder, or related security problems. The objectives you develop in each of these areas will provide the direction for your fire safety plans.

Restrictions on Reaching Objectives

It is important to realize that there can be many restrictions and technical limitations on establishing realistic fire safety objectives. For this reason fire safety objectives are usually quantified by a fire protection engineer and a building owner who together determine the design and extent of the fire protection system. Until the fire protection engineer actually becomes involved in quantifying fire safety objectives, it is better to assume zero life loss, zero property loss, zero downtime, and zero security losses as the only acceptable levels of loss. Given today's technology, zero losses are not actually obtainable but they do provide a place to start.

Reliability of Reaching Objectives

Since you are involved in planning and setting fire safety objectives, you should understand that the reliability of reaching objectives can be affected by at least three factors:

1. *Financial constraints*, such as budgetary limitations. Priorities have to be established for the allocation of limited funds. If a decision is made not to fund a certain part of a fire safety plan, the impact of that decision on the life safety, property protection, downtime, or security of the facility should be stated. This does not mean that the decision not to provide funding will change; it does mean, however, that the decision makers will be aware of the consequences.

2. *Operational constraints*. Reduced staffing, security limitations, riot conditions, and poor planning or training impact on the fire safety objectives. For example, in order to reach a certain life safety objective, it may be determined that the most economic method of occupant protection would be evacuation. However, since there is no secure area of refuge at this facility, the necessity for maintaining security eliminates evacuation to a secure area as a viable method of occupant protection.

What alternative method of occupant protection is there in such circumstances?

In this instance, the facility may have to defend the inmates in place.

3. *Technical constraints*. Because current technology does not allow for absolutes, an important consideration in the reliability of reaching fire safety objectives is to be aware of technical constraints.

Relationship to Type of Facility

An additional consideration in setting fire safety objectives is that objectives may change over time in relation to the type of facility involved. For example, objectives may be established for a medium security facility and one year later the facility is converted to a work release center. No doubt this will require a change in certain objectives due to the differing security requirements. You should also be aware that objectives for existing buildings will most likely be different from those for new buildings. This is due primarily to economic factors, especially the additional costs of renovating existing buildings.

Guidelines for Establishing Objectives

The following guidelines should be used when establishing objectives.

- Objectives should be written. Unwritten objectives may change in your mind as time passes and will often be forgotten or drastically altered due to external pressures.
- Objectives should be stated positively. It is much better to state that the fire safety system will limit fire development to one cell rather than stating that if a fire occurs it will burn out one cell.
- Objectives should be realistic and obtainable. Reaching objectives will require some effort but they must be within grasp.
- Objectives should be specific and quantifiable. It is much easier to determine the resources necessary to achieve objectives when they are specific. Also, progress can be readily evaluated.
- Objectives should have a specific time limit attached. A time must be established so that a plan with dates and schedules can be developed to reach the objectives.
- Objectives should be revised periodically. It is important to set time periods for review so that conditions can be evaluated and their impact assessed.

A COMPREHENSIVE FIRE SAFETY PLAN

The development of a comprehensive fire safety plan represents the transfer from learning about the Simplified Fire Safety System to putting that system to work. The comprehensive plan is the result of many hours of consulting, setting fire safety objectives, querying, and manipulating key resources. Its purpose is to establish in written form the who, what, when, where, and how of the plan that will allow the fire safety objectives to be achieved. Its comprehensive character ensures the cohesiveness of the entire Simplified Fire Safety System.

What goals of the Simplified Fire Safety System are included in a comprehensive fire safety plan?

A comprehensive fire safety plan involves ignition control, fuel control, occupant protection, detection and suppression activities, and planning and training — the goals of the Simplified Fire Safety System.

The plan needs to include both short-range and long-range objectives for each goal (or short-range and intermediate mileposts if this is how your objectives are written). The mileposts (or intermediate steps) are a convenient method to help keep funds properly allocated and provide direction toward reaching the long-range objectives.

Any short-term changes will probably be made within existing policy. However, changes that address long-range objectives may require a reassessment of old policies and the establishment of new ones, for example, the implementation of alternate grievance procedures and fire drills. Changes in policy such as these point out the need to involve the chief policymaker or manager in the development of all phases of the comprehensive fire safety plan. Moreover, it is the function of management to determine time, money, and resources and to select which options will be chosen in implementing the plan. Policy changes may also involve legal considerations, since most facilities are governed by policies or controlled by budgets which require approval by a lawmaking body.

Finally, in developing a comprehensive fire safety plan it is necessary to consider practical alternatives that can contribute to attainment of your goals and objectives. When planning how to reach your objectives, consider your options, including financial and operational alternatives. The approach when considering alternatives is to look first at where you want to go (the long-range objective, intermediate steps, and short-range mileposts), and then to assess your resources (hardware, personnel, funds). For example, at this time your facility may not have the funds (resources) available for installing a sprinkler system. However,

***Relationship of
Objectives to
Plan***

4

This point cannot be overstated. The ability of management to suggest practical alternatives depends on their successful implementation of a comprehensive fire safety plan. No facility has unlimited resources, either staff, machines, or money. Thus, alternatives are necessary if a plan is to get off the ground. Valuable and needed objectives should not have to be abandoned simply because alternative methods are not apparent.

there may be sufficient monies for installing a standpipe and hose system, a short-range milestone. Or perhaps you have not considered your welding or machine shop as a resource. A resource such as this may allow your facility to install a sprinkler system sooner than expected.

A PROTOTYPE FIRE SAFETY PLAN

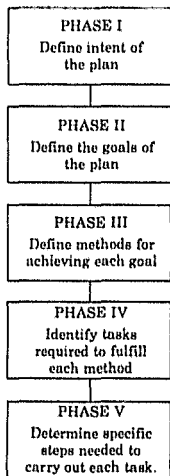

To assist you in developing your comprehensive fire safety plan, we will begin work on a fire safety plan. The plan is a prototype only; it is meant to serve as a model for the plan you and others in management must develop for your facility.

The basic method for developing a comprehensive fire safety plan is best shown by a flow chart. In a series of five phases, the flow chart indicates the overall sequence of events in developing a comprehensive fire safety plan. Although completing one phase before beginning the next is not always necessary, it does help to preserve the logical flow of developing the plan from beginning to end.

It should not be surprising to notice a similarity between the flow of developing the comprehensive fire safety plan and the Simplified Fire Safety System since the Simplified Fire Safety System was designed for the express purpose of planning fire safety in correctional facilities.

Development of the Plan

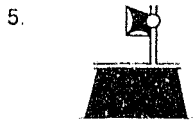

DEVELOPING A COMPREHENSIVE FIRE SAFETY PLAN (Flow Chart)

Development of the plan (Phase I) begins once management has made the commitment to fire safety. In our prototype plan we will be using the terminology (goals, methods, and tasks) that has been used in discussing the Simplified Fire Safety System, although we could just as easily have used the terms long-range objectives, intermediate steps, or short-range mileposts. Whatever terminology you use, it should be consistent and clear to all who may see the plan. Let's begin.

PHASE I: Define the intent of the plan.

The intent of the plan for this facility is to improve the overall level of fire safety by increasing life safety, property protection, and security, and by decreasing downtime.

This prototype plan will be developed for a medium security correctional facility. In any facility, some buildings may be newer, perhaps of more modern fire-resistive construction, and may even contain a sprinkler system and automatic detection devices. Your plan will have to focus on different locations within the facility, just as the prototype in this chapter does. In other words, the long-range objectives may be the same for several locations in a facility, but some locations may be further along the road toward achieving those objectives. Also, budgetary limitations and priorities enter into the plan. Your short-range mileposts will need to reflect this.

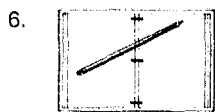

DEVELOPING A COMPREHENSIVE FIRE SAFETY PLAN (Use flow chart format, but expand boxes to facilitate notetaking.)

7. Since students will be called on to work in groups to develop a comprehensive fire safety plan, be certain your discussion of each phase is clear and covers all important points.

When you come to Phases III, IV, and V, the information (especially worksheets) should be put on transparencies or photocopied (preferably both) for inclusion in the student workbook.

PHASE II: Define the goals of the plan.

The goals of the plan are the five goals of the Simplified Fire Safety System: ignition control, fuel control, occupant protection, detection and suppression activities, and planning and training operations.

PHASE III: Define methods for achieving each goal.

As discussed, there are several methods for achieving each goal in the Simplified Fire Safety System. At this point, the plan needs to become specific to a location. Why is this so?

Why does the plan need to become specific at this point?

The plan becomes specific here because available fire protection in even one facility may differ from building to building. If one building has smoke detectors, the method "provide early warning detection" has already been accomplished and needs little mention in a plan except to note that it already exists.

In Phase III, the prototype plan addresses only cellblock C on the second floor of our imaginary facility. We will select only one method for achieving each goal, although a comprehensive plan might include additional methods.

Goal: Ignition Control
Method: Control smoking materials

Goal: Fuel control
Method: Control quantity of fuel

Goal: Occupant protection
Method: Provide reliable evacuation to a secure area

Goal: Detection and suppression activities
Method: Provide early warning detection

Goal: Planning and training operations
Method: Plan emergency procedures

PHASE IV: Identify tasks to fulfill each method.

For the prototype plan, we list two tasks needed to achieve each method. Depending on the facility and location, however, there can be many tasks. When developing your comprehensive fire safety plan, you will also need to keep in mind budgetary



8. Concept: Management and those developing a comprehensive fire safety plan need to consider practical alternative methods for achieving goals and fire safety objectives. Activity:

- (1) Conduct a brainstorming session (group discussion) centered around other possible alternatives for achieving fire safety objectives at their facility through each goal of the system.
- (2) Assign one goal to each group. In the group, suggest as many alternatives as possible within a given time limit (e.g., five minutes).
- (3) Use blackboard to report suggestions. Each group will report on their suggestions. Other groups not reporting should take notes because they will need information later for planning process.
- (4) Following are some suggestions. If enough suggestions are not forthcoming, you may want to add some from this list.

Ignition Control
Designated smoking areas
Ground-fault circuit-interrupters
Standards for electric appliances
Prohibition of stingers
Limited extension cords
Butane or electric cigarette lighters

Fuel Control
Fire retardant linens, mattresses, pillows, clothing
Limited personal property
Limited clothing, reading materials
No aerosol cans
Prohibit wall posters
Limited plastics
Metal painted with fire-retardant materials
Limited use of wood, plastic
Eliminate padded cells

Occupant Protection
Protect exits
Separate corridors
Smoke vents
Pressurized systems
Fire dampers/ducts
Secure evacuation
Self-contained breathing apparatus
Emergency lights
Posted evacuation plans

Detection and Suppression Activities
Two-way radios with fire department
Sensitize staff to behavior
Inmate fire watch
Remote fire stations
Fire equipment cart
Check water supply
Maintain fire extinguishers
Staff and inmate fire brigade
Bring in fire department
Fire blankets
Adequate staff

WORKSHEET 1: PLANNING PROTOTYPE

LOCATION: Second Floor Cellblock

The intent of the plan for this location is to improve the overall level of fire safety by increasing life safety, property protection, and security, and by decreasing downtime. Consideration must be given to the fact that each goal is interrelated to all others.

GOAL	METHOD	TASKS
Ignition Control	Control smoking materials	<ul style="list-style-type: none">• Provide quick extinguishing matches• Restrict smoking to designated areas
Fuel Control	Control quantity of fuel	<ul style="list-style-type: none">• Eliminate mattress storage• Provide metal lockers for storage of combustible inmate property
Occupant Protection	Provide reliable evacuation to a secure area	<ul style="list-style-type: none">• Change locking hardware so that no more than two keys are necessary to provide egress to a secure area• Install smoke vents in way of exit access
Detection and Suppression Activities	Provide early warning detection	<ul style="list-style-type: none">• Install temporary single-station smoke detectors in common areas of cellblock• Replace single-station detectors with cross-zoned, permanently wired smoke detector system
Planning and Training Operations	Plan emergency procedures	<ul style="list-style-type: none">• Produce a fire evacuation plan• Coordinate with fire department

limitations when the feasibility of a task is determined. At this point in the development, we will organize our work onto a sample worksheet (see Worksheet 1).

PHASE V: Determine specific steps needed to carry out each task.

Our prototype plan focuses on cellblock C on the second floor. In determining the specific steps needed to carry out each task, consideration must be given to each of the following:

- What you want to accomplish.
- When you intend to accomplish it.
- What costs will be involved.
- What internal or external resources will be necessary.

For our prototype plan we will list on Worksheet 2 the steps for the second task, "replace single-station detectors with cross-zoned, permanently-wired smoke detector system," related to the goal of detection and suppression activities. It should be clear that completing Phase V of our prototype plan requires itemizing the steps for all tasks. The worksheets provide a convenient method for keeping all points organized and readily available for comment and criticism by all involved in developing the plan.

As previously mentioned, an important part of developing a comprehensive fire safety plan, especially in Phases III through V, is choosing alternatives (methods, tasks, steps) for accomplishing the objectives of the plan. Usually it will be limited funds that will cause the search for either no-cost or more cost-effective alternatives. In order to effectively evaluate available alternatives, it is important to be aware of the potential costs involved in the purchase and/or installation of hardware related to fire protection. It is possible to obtain up-to-date costs on fire protection hardware, in terms of materials and labor costs, from *Building Construction Cost Data 1980*, published by R. S. Means, Co., Inc., Kingston, Massachusetts. This publication is revised on an annual basis.

Once your comprehensive fire safety plan has been completely developed, documented, and approved, the next logical step is implementation. It is assumed that, by the time you have finished developing the plan, management will have made the necessary decisions for implementing the plan, especially in terms of allocating financial resources. However, problems in carrying out stated tasks do arise. Two major problems that sometimes prevent corrections administrators from improving the levels of fire safety in their facilities are (1) lack of technical expertise in the area of fire protection, and (2) lack of funding. The following infor-

Planning and Training Operations
 Minimum staff training hours in CPR, SCBA, first aid
 Orientation including disaster plan
 Inmate orientation, booklet of fire safety information
 Fire safety wall posters
 Inmate fire brigade
 Minimum number of fire drills
 Emergency post assignments
 Tie-in with local law enforcement agencies
 Routine training and inspections
 Gas survey
 Establish medical procedures using local hospitals

(5) Wrap up this discussion by informing students that all alternatives must be made on an individual basis with the integrated nature of the Simplified Fire Safety System in mind. All planning requires thinking in several dimensions:

- time
- money
- limitations
- alternatives

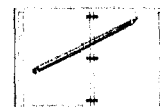

PLANNING ALTERNATIVES

Goal: Ignition Control

Methods:

- 9
- Control smoking material
 - Control electrical ignition sources
 - Use alternative grievance procedures

Alternatives from Group Discussion
 Note: Use a similar format for the remaining four goals.

9.



Concept: Management should be able to specify the steps required to complete each task of their comprehensive fire safety plan.

Activity:

- (1) Have students begin work on the outline of their plan by completing the following steps.
- a. Choose a location in their facility which needs attention to improve fire safety.

TECHNICAL AND FINANCIAL ASSISTANCE

b. For each goal, choose one method from those listed for the Simplified Fire Safety System for Correctional Facilities.

c. For each method, select two tasks from available technology notes or notes on alternatives from group discussions. This is Phase IV of developing a plan (see Worksheet 1).

d. Choose one task and outline the logistical steps needed to complete the task, or if time permits, for two tasks. This is Phase II of developing a plan (see Worksheet 2).

(2) After step C above, ask some students to present their tasks. Ask them why they chose particular options. Repeat this procedure after students complete step D also. Other students may be able to suggest steps which were overlooked.

TYPES OF TECHNICAL ASSISTANCE

mation will help make you aware of the types of technical and financial assistance currently available to assist you in implementing your overall fire prevention and protection plan.

After reading about the types of technical assistance and some of the more readily accessible sources for obtaining it, you will complete a chart to help you organize the sources according to the specific type of technical assistance provided (see Table 8.1).

WORKSHEET 2: PLANNING PROTOTYPE		
LOCATION: Second Floor Cellblock		
GOAL	METHOD	TASKS
Detection and Suppression Activities	Provide early detection	<ul style="list-style-type: none"> • Install temporary single-station smoke detectors in common areas of cellblock • Replace single-station detectors with cross-zoned, permanently wired, smoke detector system.
<p>TASK: Replace single-station detectors with cross-zoned, permanently wired smoke detector system.</p> <p>STEPS:</p> <ul style="list-style-type: none"> A. Evaluate internal/external resources. B. Establish design parameters. C. Determine cost estimates based on available resources and design parameters. D. Submit estimate to budget cycle by June 30, 1981. E. Hire engineer by October 15, 1981. F. Review preliminary plans by December 15, 1981. G. Finalize plans by February 15, 1982. H. Advertise for bid by March 15, 1982. I. Select contractor by April 15, 1982. J. Complete construction by September 30, 1983 including removal of single-station detectors. K. Implement maintenance and testing. 		

The chart will provide a quick reference guide to technical sources when you begin developing your own comprehensive fire safety plan.

There are at least six types of technical assistance useful for improving fire protection in correctional facilities: (1) engineering, (2) design and construction, (3) education and training, (4) planning, (5) fire protection hardware, and (6) consumer products or materials. Some of these areas of technical assistance overlap in one way or another. It may not be necessary for a corrections administrator or his staff to seek outside expertise in all these areas, especially if he or members of his staff have in-house capabilities.

1. *Engineering.* Technical expertise in the field of fire protection engineering is essential if the overall fire safety plan calls for installation of fire detection, alarm, and suppression systems. Several national organizations and many private companies offer this type of assistance, which can be especially valuable when plans call for a renovation of the correctional facility. Occasionally, local fire departments will have a fire protection engineer on the staff of their fire prevention bureau and some state fire marshals will have a fire protection engineer on their staffs.

2. *Design and Construction.* Expertise in the field of design and construction with respect to fire protection is necessary when plans call for new construction of a correctional facility. Since fire protection features can be designed before construction has started, this is the most efficient way of ensuring that the construction of the facility will meet fire safety requirements. Too often the construction planning process overlooks designing fire safety into a structure or relegates it to a minor consideration. Technical expertise for this type of assistance can be found in many fire protection engineering firms, architectural firms, universities, and state fire marshals' offices.

3. *Education and Training.* Included in the area of educational technical assistance are developing training programs for inmates and officers regarding an overall fire prevention program, emergency operating procedures, and use of fire suppression equipment. Once educational programs have been developed, expertise in implementing or conducting training sessions may be needed. This area of assistance involves advice on who to train, how to train, and how to evaluate the effectiveness of the training.

4. *Planning.* Expertise may be needed in the area of planning: that is, organizing schedules and developing cost controls and budgets to implement short- and long-range fire protection plans. In addition, expertise is necessary to develop pre-fire plans for every part of the facility.

5. *Fire Protection Hardware.* Fire protection equipment manufacturers quite often provide assistance to their customers regarding location and installation of their products such as heat

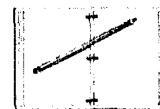

10 DEVELOPING A PLAN (for step C)

Location:
Goal: Ignition Control
Method
Tasks
1.
2.

DEVELOPING A PLAN (for step D)

Location
Goal
Method
Tasks
Steps

10. Rather than simply present the information on technical assistance, especially the sources of assistance, duplicate and distribute the information among the students. You may wish to prepare a transparency of the complete Table 8.1 to assist students in organizing the sources of technical assistance. After students have read the information, ask if anyone has had experience with sources other than those presented in their duplicated pages. If so, write the source and its expertise on a chalkboard for reference.

Table 8.1

SOURCES OF TECHNICAL ASSISTANCE

The following chart is arranged according to type of technical assistance and general categories of the sources of technical assistance. For each type of technical assistance, list the sources of technical assistance alongside the appropriate category. For example, in the Engineering category and under Private Assistance, you would probably include the Society of Fire Protection Engineers in your list. There is also adequate space to include other sources you may be aware of and to make notes regarding the various sources. Remember, this chart is intended to serve as a reference to help you in developing a comprehensive fire safety plan for your facility.

	PRIVATE ASSISTANCE	PUBLIC ASSISTANCE		
	National Agencies	Local and County	Regional or State	Federal
ENGINEERING				
DESIGN AND CONSTRUCTION				
EDUCATION AND TRAINING				
PLANNING				
FIRE PROTECTION HARDWARE				
CONSUMER PRODUCTS AND MATERIALS				

and smoke detectors, fire alarm systems, and sprinkler systems. Also, technical information can be acquired from manufacturers of automatic locking devices, fire doors, and smoke ejection systems.

6. *Consumer Products or Materials.* In order to avoid increasing the fire load in the confines of cells and cellblocks, information is needed regarding furniture and interior finish materials which are relatively fire safe. Experts in this area are found in organizations such as the Consumer Product Safety Commission, the state fire marshal's office, and consulting engineers.

In order to help you obtain technical assistance, names and addresses of major organizations have been included at the end of this section.

SOURCES OF TECHNICAL ASSISTANCE

At the local level, fire departments are a resource in some areas of fire protection technical assistance. They usually can provide assistance in developing emergency operating procedures, educational and training programs for inmates, officers, and fire brigades, and drawing up pre-fire plans (especially if they are the ones who respond to a fire alarm). Fire department personnel are also knowledgeable, especially in the larger municipal departments, in engineering and in design and construction with respect to fire protection. The municipal building department or planning department can offer assistance in the areas of engineering, design and construction, especially with respect to local and state building and fire safety codes. Local educational institutions may be able to offer educational and training assistance, and they may have fire protection engineering programs useful to the corrections administrator.

Public Assistance

In rural areas or in a community with a volunteer or call fire department, the corrections administrator can look for technical assistance from county, regional, and state organizations, such as the county fire department, county fire chiefs' associations, regional planning commissions and vocational technical schools, in addition to the local fire department.

At the state level, the state fire marshal's office should be able to offer assistance in most areas of fire-related expertise, especially if the fire marshal's office has responsibility for inspecting state correctional facilities. The state building department can offer engineering, design and construction assistance. Training and educational assistance can be obtained from the state department of education, which generally has a program for training fire fighters.

On the national level, there are several federal agencies and departments that offer technical assistance in areas of fire protection. The United States Fire Administration (Federal Emergency Management Agency) provides technical assistance related to the

prevention, occurrence, control, and results of fires. It encourages and assists in developing new and improved programs in fire technology and provides related information.

The National Bureau of Standards (NBS — Department of Commerce) through its Institute for Applied Technology provides technical services to promote the use of available technology and to facilitate technological innovation in industry and government. NBS cooperates with public and private organizations in the development of technological standards. Fire technology efforts are oriented toward research in improved building safety through better materials, fire suppression systems, detectors, improved fire fighting techniques and equipment, and decreased fire hazards in clothing, house furnishings, and consumer products.

The Consumer Product Safety Commission (independent federal agency) can offer technical advice on the safety of products with respect to flammability and fuel content. The purpose of the commission is to protect the public against unreasonable risks of injury from consumer products and to promote research and investigation into the causes and prevention of product-related deaths, illnesses, and injuries.

Two divisions of the Bureau of Prisons (Department of Justice) can offer assistance in the areas of engineering, design and construction, education, training, and planning. The Planning and Development Division has responsibility for long-range construction and program planning, development and construction of new facilities, and maintenance services for existing institutions. Although this division is primarily involved with federal institutions, local and state corrections administrators can gain knowledge from the Division's construction and maintenance experience with respect to fire protection. The Correctional Programs Division has responsibility for programs directly affecting offenders and staff, including education, vocational training, and personnel management and training.

The National Institute of Corrections (Department of Justice) was established to provide guidance at the federal level for upgrading the state and local corrections network. The Institute conducts training programs to develop staff at the local and state levels. It conducts, encourages, and coordinates research and evaluation of correctional operations and programs. NIC also serves as a clearinghouse and information center for the collection, preparation, and dissemination of correctional information and provides technical assistance to state and local corrections. The National Jail Center, as part of the National Institute of Corrections, is responsible for training and assisting the nation's approximately 4,000 jails. It also aids in developing various rehabilitation programs for jails.

Through the Department of Agriculture's Agricultural Research Service, reports on research into the development of

flame- and smolder-resistant cotton products suitable for use in mattresses can be obtained.

Private Assistance

The National Fire Protection Association (NFPA) is a technical and educational membership organization concerned with the causes, prevention, and control of destructive fire. The Association's activities may be summarized as follows: (1) information exchange; (2) fire safety technical standards development; (3) technical advisory services; (4) public education; (5) fire safety research; and (6) services to public protection agencies.

Since its organization in 1950, the Society of Fire Protection Engineers has been involved in the multifaceted field of fire protection engineering. The purposes of the Society are to advance the art and science of fire protection engineering and its allied fields, to maintain a high ethical standard among its members, and to foster fire protection engineering education. Its worldwide members include engineers in private practice, in industry, in local, regional, and national government, as well as technical members of the insurance industry. Chapters of the Society are currently located in major cities of the United States, Canada, Europe, and Australia.

Although it is not possible to list all the private fire protection engineering firms which are available to offer technical services, firm names and addresses may be obtained through the Society of Fire Protection Engineers. These firms are in business to provide assistance in establishing fire safety objectives, to perform fire protection audits of existing structures, and to design and develop a fire protection program that includes, among other things, installation, review, and acceptance testing of fire protection equipment.

Several organizations are involved in developing codes, standards and guidelines for correctional facilities with respect to life safety, construction and planning, and treatment of inmates. A few of the standards specifically address fire protection. The Commission on Accreditation for Corrections publishes the *Manual of Standards for Adult Correctional Institutions*. The commission is sponsored by the American Correctional Association. The National Clearinghouse for Criminal Justice Planning and Architecture publishes *Guidelines for the Planning and Design of Regional and Community Correctional Centers for Adults*. The National Fire Protection Association publishes the *Life Safety Code*, which contains requirements for building design and construction. Proposed chapters for the *Code* relating to new and existing correctional facilities have been included in Appendix B of this manual. More generally, national codemaking groups publish model building and fire safety codes. These include: Building Officials and Code Administration International (BOCA), Homewood, IL;

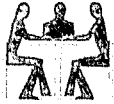

Concept Management should be aware of the various sources of technical assistance and be able to select appropriate sources(s) to assist them in developing the comprehensive fire safety plan.

Activity.

(1) Suggest the following: after evaluating their correctional facility, they have decided to upgrade each goal of the Simplified Fire Safety System in order to meet minimum objectives for fire safety.

11

SOURCES OF TECHNICAL ASSISTANCE

(2) For each goal, students should choose one method to focus on and write that method in the appropriate space (see workbook symbol below).

(3) Students should then consult their duplicated pages listing the sources of technical assistance and specify one or more possible sources of technical assistance related to that method.

(4) Students can either work individually on this exercise and then come together to reach a group answer or work in groups immediately.

(5) As each group reports, write their suggestions for technical assistance on the board or on an overhead transparency.

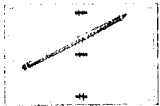

FINDING SOURCES OF TECHNICAL ASSISTANCE

Goal: Ignition Control

Method

Sources

International Conference of Building Officials (ICBO), Whittier, CA; Southern Building Code Congress International (SBCC), Birmingham, AL.

Private educational consulting firms are available to provide services in materials development for training purposes. They can also be hired to develop staff training programs dealing with emergency operating procedures. Manufacturers of fire protection equipment are available to supply the equipment and install it according to the specifications of fire protection engineers.

Building Officials and Code Administration International
17926 S. Halstead Street
Homewood, Illinois 60430

Bureau of Prisons
320 First Street S.W.
Washington, D.C. 20534

Commission on Accreditation for Corrections
377 Park Avenue S.
New York, N.Y. 10016

Consumer Products Safety Commission
1111 Eighteenth Street N.W.
Washington, D.C. 20534

Department of Agriculture
Agricultural Research Service
Fourteenth Street & Independence Avenue
Washington, D.C. 20250

International Conference of Building Officials
5360 S. Workman Mill Road
Whittier, California 90601

National Bureau of Standards
Route 1-270 & Quince Orchard Road
Gaithersburg, Maryland
Mailing address - Washington, D.C.

National Clearinghouse for Criminal Justice
Planning and Architecture
505 E. Green Street Suite 200
Champaign, Illinois 61820

National Fire Protection Association
Batterymarch Park
Quincy, Massachusetts 02269

National Institute of Corrections
U.S. Department of Justice
320 First Street N.W.
Washington, D.C. 20534

Society of Fire Protection Engineers
60 Batterymarch Street
Boston, Massachusetts 02110

Southern Building Code Congress International
900 Montclair Road
Birmingham, Alabama 35231

United States Fire Administration
1725 I Street N.W.
Washington, D.C. 20472

In this section, some available sources of financial assistance are described. Such financial assistance may be all that is required to get your comprehensive fire safety plan or any part of the plan off the ground and into action. Depending on the source and type of financial assistance program, funds can be used for a variety of improvements:

- To expand the field of fire protection technology in correctional institutions by means of research and development funds. These funds can be used to finance pilot or experimental programs in an institution which, if effective, may be transferred to other institutions.
- To install, acquire, or improve fire protection equipment and apparatus.
- To develop or improve general fire prevention and suppression programs, such as the development of emergency operating procedures or evacuation plans.
- For a specific fire safety program which may feature a priority focus of the funding organization. An example would be funds allocated to purchase or install smoke detectors or a program to replace high hazard materials such as highly combustible mattresses.
- For the purchasing of fire insurance.
- For personnel procurement and training. For example, an institution may be awarded funds to train, organize, and equip a fire brigade.

In many cases, but not always, an organization which is a source of technical assistance in a certain area is also a source of financial assistance for programs and projects in that area. Many organizations, even though they do not have the capability to offer technical assistance in a certain area, may offer funding for area-related improvements. Conversely, an organization with the capability and willingness to offer technical assistance may not have the capability to offer financial assistance. This may be the case because the organization is a private, profit-making company whose business it is to provide technical assistance for a fee. Also,

FINANCIAL ASSISTANCE

12.

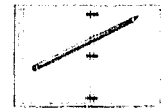

12

FINANCIAL ASSISTANCE
Improvements for which monies are
available:

an organization with the power to grant financial assistance may have already allocated all available funds for the current funding cycle.

There are many ways in which financial assistance can be made available by an organization to the user. The following methods are most common when the funding source is a private, nonprofit organization or a governmental agency:*

13.

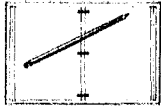

FORMS OF FINANCIAL ASSISTANCE

Description of each (written)
Types

Ask students to investigate sources of assistance. They can determine how much money is available, from whom, for what types of improvement.

13

- *Formula Grants:* Allocations of money to states or their subdivisions in accordance with distribution formulas prescribed by law or administrative regulation, for activities of a continuing nature not confined to a specific project. Revenue sharing, a type of formula grant, provides federal financial aid to states, counties, cities, and townships without specifying how the money is to be spent. The priorities are determined locally.

- *Project Grants:* The funding, for fixed periods, of specific projects or the delivery of specific services or products without the liability for damages or failure to perform. Project grants include fellowships, scholarships, research grants, training grants, traineeships, experimental and demonstration grants, evaluation survey grants, construction grants and unsolicited contractual agreements.

- *Discretionary Grants:* Allocation of funds at the discretion of the funding agency for broad purposes to fulfill a long-range goal or priority of the agency.

- *Direct Loans:* Financial assistance provided through the lending of federal monies for a specific period of time, with a reasonable expectation of repayment. Such loans may or may not require the payment of interest.

- *Guaranteed/Insured Loans:* Programs in which the federal government makes an arrangement to indemnify a lender against part or all of any defaults by those responsible for repayment of loans.

- *Research Contracts:* Federal assistance designed to support research in situations where the transmission of funds would be better handled through contracts rather than through grants. The research contract is for personal or professional services, or for any service to be rendered by a university, college, hospital, public agency, or nonprofit institution. The principal purpose of such contracts is to create, develop, or improve products, processes or methods for public use, or to operate programs benefiting the public.

- *Matching Funds:* Many of the financial assistance programs just listed may require the grantee to match the award amount. Some limitations are usually placed on how the grantee

*Sources of Federal Funds for Fire Programs, United States Fire Administration, Washington, DC, 1978, p. 84.

may acquire the other funds. For example, the grantee cannot use the potential of another grant to match funds.

It should be clear that technical and financial assistance is available to you. If your facility encounters a problem in either of these areas when setting up your plan, the time to act in obtaining assistance is early in the development of the plan. Thus, once development of a comprehensive fire safety plan is complete, implementation of the plan can and should begin immediately.

Although developing a comprehensive fire safety plan may appear to be a wasted effort or a low priority, especially in comparison to the many other more urgent day-to-day tasks, fire safety cannot be achieved without it. Without a comprehensive plan, fire safety will be haphazard at best, and at the very least, your facility will spend more funds in the process. As a corrections administrator, you have many available alternatives to achieve a high level of fire safety in your facility. A comprehensive fire safety plan is the one alternative you cannot do without.

Now, let's review.

CHAPTER REVIEW

14 14. Follow the instructions specified for the Chapter Review in Chapter One.

1. Planning includes: (check any that apply)
 - a. Formulating objectives.
 - b. Devising a strategy for achieving the objectives.
 - c. Setting up the operations.
 - d. Performing the operations.
 - e. Allocating resources.
 2. Specify the allocation of resources most likely to be involved in long-range planning by writing LR, and those most likely to be involved in short-range planning by writing SR.
 - Manpower.
 - Development of an emergency operating plan.
 3. List the four areas in which fire safety objectives for correctional facilities are established.
 - a. _____
 - b. _____
 - c. _____
 - d. _____
- Inspection procedures.
 - Purchase of major apparatus.
 - Purchase of SCBA's.
 - Fire safe building construction.
 - Installation of automatic sprinklers.
 - Staff and inmate education and training.

4. List the three factors that affect the reliability of reaching objectives.

- a. _____
- b. _____
- c. _____

5. What means are available for helping you to keep focused on achieving your long-range objectives?

6. What does the term "comprehensive" represent in relation to developing a comprehensive fire safety plan for a correctional facility?

7. Briefly explain the function of management in developing and implementing the comprehensive fire safety plan.

8. Identify the five basic phases of developing a comprehensive fire safety plan.

- a. _____
- b. _____
- c. _____
- d. _____
- e. _____

9. List the five goals of the Simplified Fire Safety System.

- a. _____
- b. _____
- c. _____
- d. _____
- e. _____

10. What are the two major problems which may prevent corrections administrators from improving levels of fire safety in their facilities?

- a. _____
- b. _____

**RELATED
CODES
AND
STANDARDS**

A code or standard is a document which contains mandatory provisions and minimum requirements. A number of standards-making groups publish codes and standards that impact on the fire protection needs of correctional facilities. Among these are the National Fire Protection Association (NFPA), Underwriters Laboratories Inc. (UL), and the American Society for Testing and Materials (ASTM). Some of their codes and standards have been mentioned in the text of this manual. Those codes or standards which relate most closely to methods of control cited in the Simplified Fire Safety System are listed in this Appendix. Complete catalogs of published codes and standards as well as the publications themselves may be obtained from the following:

National Fire Protection Association
Batterymarch Park
Quincy, MA 02269

Underwriters Laboratories Inc.
333 Pfingsten Road
Northbrook, IL 60062

American Society for Testing and Materials
1916 Race Street
Philadelphia, PA 19103

Number	Title
10	<i>Portable Fire Extinguishers</i>
13	<i>Installation of Sprinkler Systems</i>
13A	<i>Care and Maintenance of Sprinkler Systems</i>
14	<i>Installation of Standpipe and Hose Systems</i>
19B	<i>Respiratory Protective Equipment for Fire Fighters</i>
24	<i>Outside Protection</i>
27	<i>Private Fire Brigades</i>
30	<i>Flammable and Combustible Liquids Code</i>
70-78	<i>National Electrical Code</i>
70B	<i>Electrical Equipment Maintenance</i>
70E	<i>Electrical Safety Requirements for Employee Work Places</i>
72C	<i>Remote Station Protective Signaling Systems</i>
72E	<i>Automatic Fire Detectors</i>
80	<i>Fire Doors and Windows</i>
82	<i>Incinerators, Waste and Linen Handling Systems and Equipment</i>
90A	<i>Air Conditioning and Ventilating Systems</i>
101	<i>Life Safety Code</i>
220	<i>Standard Types of Building Construction</i>
251	<i>Standard Methods of Fire Tests of Building Construction and Materials</i>
255	<i>Method of Test of Surface Burning Characteristics of Building Materials</i>
1001	<i>Fire Fighter Professional Qualifications</i>
1901	<i>Automotive Fire Apparatus</i>
1961	<i>Fire Hose</i>
1962	<i>Care, Maintenance, and Use of Fire Hose</i>

**CODES AND
STANDARDS
FROM NFPA**

**CODES AND
STANDARDS
FROM UL**

Number	Title
9	<i>Fire Tests of Window Assemblies</i>
10B	<i>Fire Tests of Door Assemblies</i>
14B	<i>Sliding Hardware for Standard Horizontally Mounted Tin-Clad Fire Doors</i>
14C	<i>Swinging Hardware for Standard Tin-Clad Fire Doors</i>
18	<i>Unlined Fire Hose</i>
19	<i>Woven-Jacketed Rubber-Lined Fire Hose</i>
57	<i>Electric Lighting Fixtures</i>
63	<i>Fire Door Frames</i>
92	<i>Fire Extinguisher and Booster Hose</i>
154	<i>Carbon Dioxide Fire Extinguishers</i>
199	<i>Automatic Sprinklers for Fire Protection Service</i>
228	<i>Door Closers, Holders, and Integral Smoke Detectors</i>
246	<i>Hydrants for Fire Protection Service</i>
263	<i>Fire Tests of Building Construction</i>
268	<i>Smoke Detectors for Fire Protective Signaling Systems</i>
299	<i>Dry Chemical Fire Extinguishers</i>
401	<i>Portable Spray Hose Nozzles for Fire Protection Service</i>
405	<i>Fire Department Connections</i>
437	<i>Key Locks</i>
448	<i>Pumps for Fire Protection Service</i>
464	<i>Audible Signal Appliances</i>
521	<i>Heat Detectors for Fire Protective Signaling Systems</i>
531	<i>Single and Multiple Station Heat Detectors</i>
924	<i>Emergency Lighting Equipment</i>
983	<i>Surveillance Cameras</i>

**CODES AND
STANDARDS
FROM ASTM**

Number	Title
E69	<i>Fire Test for Combustible Properties of Treated Wood by Fire Tube Apparatus</i>
E84	<i>Fire Test for Surface Flammability of Building Materials</i>
E108	<i>Fire Test on Roof Coverings</i>
E119	<i>Fire Tests of Building Construction and Materials</i>
E136	<i>Fire Test for Combustibility (Behavior) of Materials in a Vertical Tube Furnace</i>
E152	<i>Fire Tests of Doors/Door Assemblies</i>
E160	<i>Fire Test for Combustible Properties of Treated Wood by Crib Test</i>
E162	<i>Fire Tests of Materials Using a Radiant Heat Energy Source</i>
E163	<i>Fire Tests of Windows/Window Assemblies</i>
E286	<i>Fire Tests of Building Materials, Using an 8-ft. Tunnel Furnace</i>
E684	<i>Fire Tests of Floor Coverings</i>
E136	<i>Fire Test for Fire Retardancy of Paints (Cabinet Method)</i>
D2859	<i>Fire Test for Flammability of Finished Textile Floor Covering Materials</i>

**SUMMARY OF
PROPOSED
LIFE SAFETY
CODE
CHAPTERS**

When the NFPA Committee on Safety to Life recognized that the problem of fires in detention and correctional facilities was not adequately addressed in Chapter 10 of the *Life Safety Code*, they appointed a new sub-committee to draft a standard specifically addressing fire safety in these facilities. "Detention and Correctional Facilities" will be contained in Chapters 14 and 15 of the 1981 edition of the *Life Safety Code*.

Chapter 14 will address new detention and correctional facilities while Chapter 15 will address existing facilities. Retroactive application of standards is considered reasonable and necessary where a threat to life is apparent. The standard recognizes that equivalent but different systems are possible and may be permitted, provided that such alternative systems will provide an equivalent safety to life. The following is a discussion of the *Life Safety Code* requirements in the draft of Chapters 14 and 15 which will be voted on at the NFPA fall meeting in 1980. The 1981 version of NFPA 101, *Life Safety Code* will be available for purchase in January, 1981. A handbook for using the *Life Safety Code* will be available in June, 1981.

Five types or classes of restraint are generally used in detention and correctional facilities. These uses directly affect the fire protection requirements because they describe the ease of movement of the occupants and therefore the built-in fire protection required. The use conditions are defined as follows.

Use Condition I - Free Egress: Free movement is allowed from sleeping area and other spaces where access or occupancy is permitted, to the exterior via means of egress meeting the requirements of this code. For example, work-release centers where the doors are not locked would be considered Use Condition I and are not considered detention and correctional facilities by this chapter of the *Life Safety Code*.

Use Condition II - Zoned Egress: Free movement is allowed from sleeping areas and any other occupied smoke compartment to other smoke compartments.

Use Condition III - Zoned Impeded Egress: Free movement is allowed within individual smoke compartments (such as within a residential unit comprised of individual sleeping rooms, and within group activity space) with egress from that smoke compartment to another smoke compartment provided by remote-control unlocking of doors.

Use Condition IV - Impeded Egress: Free movement is restricted from an occupied space. Remote control release is provided to permit movement from all sleeping rooms, activity spaces, and other occupied areas within the smoke compartment to other smoke compartment(s).

Use Condition V - Contained: Free movement is restricted from an occupied space. Staff controlled manual release at each door is provided to permit movement from all sleeping rooms, activity spaces, and other occupied areas within the smoke compartment to other smoke compartment(s).

All detention and correctional facilities or those portions of facilities housing inmates must be provided with twenty-four hour staffing on any floor level having residency and located within 100 feet of the access way to any housing area. Under Use Conditions III, IV and V, audio monitoring should be provided for every sleeping space.

BUILDING CONSTRUCTION

Building construction has generally not been a problem in detention and correctional facilities which are usually designed of heavy masonry construction in order to provide security. This heavy masonry construction also provides fire resistance. Some exceptions to this noncombustible masonry construction have been the application of wood roofs over large cell areas. This was the case in Columbus, Ohio where 320 persons were killed in 1930 as a result of a fire involving a wood roof.

Buildings three or more stories high should be of fire-resistive construction. Although less desirable, buildings designed with combustible materials may be used for one and two story buildings. Since these combustible buildings contribute to their own destruction by providing fuel for fire, special consideration and precautions are necessary.

Evaluation of the effect of building materials during fire must include the production of smoke and toxic materials. Many cellulosic materials, even those provided with fire retardants, may produce large quantities of smoke. The use of plastic building materials should be carefully evaluated. This may include such common materials as mattresses and pillows.

SUB-DIVISION OF BUILDING SPACES

Any area with greater hazards than those usually encountered in detention and correctional facilities and located in the same building should be separated with construction having not less than one hour fire resistance. Such areas include general storage, boiler and furnace rooms, fuel storage areas, janitors' closets, maintenance shops, laundries, and kitchens. An alternative to one hour fire separation is automatic sprinkler protection. Where the hazard is severe, both the fire resistant separation and automatic sprinklers should be provided. For example, padded cells are considered severe hazard areas.

Sections of detention and correctional facilities may be classified as "other occupancies" if they are not intended to serve inmates for purposes of housing, customary access, or means of egress and if they are adequately separated from areas of detention and correctional occupancies by two-hour fire-resistive construction. Also, detention and correctional occupancies located in buildings housing other occupancies should be separated from the other occupancies by construction having a minimum of two-hour fire resistance.

Smoke Barriers

Smoke barriers should be provided regardless of building construction:

- a. To divide every floor used by inmates for sleeping or any other floor having an occupant load of 50 or more persons into at least two compartments.
- b. To limit the housing to a maximum of 200 inmates in any smoke compartment.
- c. To limit the travel distance to a door in a smoke barrier from any room door required as exit access to 100 feet (200 feet for existing facilities), or from any point in a room to 150 feet (250 feet for existing facilities). A horizontal exit, when constructed to satisfy the additional criteria imposed upon construction of smoke stop barriers, may be used as a desirable alternate to a smoke stop partition. Other alternatives to smoke partitions are: spaces having direct access to a public way; a building separated from the inmate housing area by two-hour fire resistance or 50 feet of open space; an enclosed area having a holding space 50 feet from the housing area that provides 15 square feet or more of refuge area per person.

Smoke partitions shall be continuous from outside wall to outside wall and from floor slab to the underside of the floor slab or roof slab above, including continuity through all concealed spaces such as those found above suspended ceilings. Smoke partitions should be of substantial construction and should have structural fire resistance of at least 30 minutes. Fixed wired glass vision panels may be used in such barriers, provided they do not exceed 1,296 square inches each in area and are mounted in approved steel frames. There is no restriction on the total number of such vision panels in any barrier. In other words, the smoke barrier may consist of a series of 1,296 square inch wired glass panels in steel frames, slab to slab. At least six net square feet per occupant should be provided on each side of the smoke barrier for the total number of occupants in adjoining compartments. This six net square feet may consist of areas in corridors and rooms.

Door openings in smoke barriers shall swing in the direction of egress. In existing facilities, doors in smoke partitions are not required to swing in the direction of exit travel. In those applications where egress may be in either direction, a pair of swinging doors should be provided with each door swinging in opposite directions. Doors in smoke barriers should be self-closing or automatic closing and should be self-latching. Smoke barrier doors in Use Condition II should be unlocked; in Use Conditions III and IV, doors may be locked but should be provided with remote release capabilities; in Use Condition V the doors in smoke partitions may be locked with a key. Doors in smoke barriers should be provided with transparent wired-glass vision panels (not to exceed 720 square inches) mounted in steel frames. The minimum width for doors in smoke barriers should be 32 inches.

Ducts penetrating smoke barriers should be equipped with fire dampers arranged to close by operation of smoke detectors located within the area in which the duct takes suction. However, such dampers are not required in buildings designed with an engineered smoke control system in accordance with NFPA 90A, *Installation of Air Conditioning and Ventilating Systems*.

The current technology on smoke control is limited to systems that limit or prevent the migration of smoke from one compartment to another. Adaptation of conventional air handling systems may permit the creation of pressure differentials across physical barriers, such as floors or partitions, to prevent smoke transfer. The effectiveness of smoke partitions may be significantly improved by the use of smoke control systems. Exhaust fans, smoke vents, and other equipment for relieving smoke from the fire area can assist in smoke control, but cannot be expected to make the fire area safe and cannot be substituted for compartmentation, detection, evacuation, extinguishment, and other fire protection features.

The tendency of fire and fire-produced contaminants to spread vertically within a building is a recognized phenomenon. Special effort is required to minimize the vertical travel of smoke and fire.

All vertical openings between stories, such as stairways, elevators, light or ventilation shafts should be enclosed, and their construction should have a two-hour fire-resistive rating. One-hour rated enclosures are acceptable in buildings of one-hour fire-resistive construction or less. Stairs that do not connect to a corridor, do not connect more than two levels, and that do not serve as a means of egress, do not have to be enclosed; however, the effects of vertical fire and smoke movement for each opening must be assessed. In facilities completely equipped with ap-

PROTECTION OF VERTICAL OPENINGS

proved automatic sprinkler systems, the resistance of shaft enclosures may be reduced to one hour in buildings up to and including three stories in height.

Enclosure protection may be omitted for two communicating floor levels, providing each of the following conditions are met:

- a. The entire area, including all communicating floor levels, is sufficiently open and unobstructed so that it may be assumed that a fire or other dangerous condition in any part of the facility will be immediately obvious to the occupants or supervisory personnel in the area.
- b. Exit capacity is sufficient to provide egress simultaneously for all occupants of all communicating levels and areas. All communicating levels in the same fire area are considered as a single floor area for purposes of determination of required exit capacity. In other words, since there is no separation, both floors are considered within the same fire area. Therefore, the exits must be sufficient for both floor areas. At least one half of the required exit capacity for each floor level is accessible from that floor level.

EXIT DESIGN

Special consideration must be given to exit facilities in a detention and correctional facility. The major difference between this type of facility and other occupancies is that the doors are normally locked to maintain security. Since security is a primary consideration, the *Life Safety Code* has addressed this issue and allowed for special exceptions to normally accepted exit requirements.

At least two exits located remotely from each other should be accessible to each floor, fire compartment, or smoke compartment of the building. Horizontal exits may be substituted for other exits, provided the maximum exit travel distance is not exceeded. Also, horizontal exits may comprise 100 percent of the exits required. In other words, each smoke compartment is not required to have a separate door or stairs leading directly outside, but may have two horizontal exits leading from that area to other smoke compartments, provided that the adjoining smoke compartments do have stairs or doors leading directly outside.

Every sleeping room should have a door leading directly outside or to an exit access corridor. However, one adjacent room such as a day room or group activity space may intervene. Where individual sleeping rooms adjoin a day room or group activity space which serves as access to an exit way, the sleeping rooms may open directly onto the day space and may be separated by one-half or a full story in height, provided exit travel distance is not exceeded.

Exit discharge may terminate directly at the building's exterior or at a horizontal exit and may discharge into a fenced or walled courtyard, provided that not more than two walls of the courtyard are the building walls from which exit is being made. These enclosed yards or courts shall be of sufficient size to accommodate all occupants a minimum of 50 feet from the building with a net area of fifteen square feet per person. This provision allows inmates to be evacuated to enclosed courtyards, such as ballfields, and therefore helps to maintain security in case of a fire.

Doors in means of egress in other occupancies are required to be of the side-hinged swinging type. However, in detention and correctional facilities, horizontal sliding type doors may be permitted, provided the force to slide a door to its fully opened position does not exceed fifty

pounds with a perpendicular force against the door of fifty pounds. Also, sallyports (security vestibules) may be permitted in means of egress when there are provisions for continuous and unobstructed passage through the sallyport during emergency conditions. In other words, both doors of the sallyport must be capable of being opened at the same time.

Doors from areas of refuge to the exterior may be locked with a key. Locks to such doors shall be operable from the outside. Keys to unlock these doors shall be maintained and available at the facility at all times and should be readily identified by sight, such as color coding, and by touch, such as by notching or rivets, so that they may be identified in the dark. Where locking of required means of egress is necessary, an adequate number of staff should be available for the supervised release of occupants during all times of use.

Remote release devices used in the means of egress should be provided with reliable means of operation remote from the inmate living areas to release all locks on all doors. Provisions for remote unlocking may be waived, provided not more than ten doors are necessary to be unlocked in order to remove all occupants from one smoke compartment to an area of refuge as promptly as they could be removed with remote unlocking. Individual door unlocking requires both manpower and time and should be evaluated for each circumstance. In no case should more than two separate keys be required to move the occupants to a separate smoke compartment.

Prompt evacuation is intended to be accomplished between the time of fire detection, whether automatic or manual, and the time the fire produces intolerable conditions. Fire tests have indicated that the time available depends on the volume and height of the space and the rate of fire development. In traditional single story corridor arrangements, the time between detection by smoke detectors and the advent of lethal conditions down to head height can be as short as three minutes. Also, it can be expected that approximately one minute will be required to evacuate all the occupants of a threatened smoke compartment once the locks are released.

All power-operated sliding doors or power-operated locks for swinging doors should be constructed so that in the event of power failure a manual mechanical means, operable from a remote location or key lock at the individual door, can be used to release the door. Power-operated sliding doors or power-operated locks for swinging doors shall be arranged so that under emergency conditions, the door will not automatically relock when closed unless specific action is taken at the remote location to enable such doors to relock. Emergency power should be provided for all electrical power-operated sliding doors and power-operated locks. Power should be arranged to automatically operate upon failure of normal power within ten seconds and to maintain emergency power sources for at least one and one-half hours.

The occupant load for which means of egress should be provided for any floor should be the maximum number of persons intended to occupy that floor, but in no case less than one person for each 120 square feet of gross floor area.

The maximum travel distance for detention and correctional facilities is divided into three categories:

1. Where the maximum travel distance between any room door required as exit access and an exit does not exceed 100 feet.
2. Where the maximum travel distance between any point in a room and an exit access does not exceed 150 feet.

3. Where the exit travel distance between any point in a sleeping room or suite and an exit access door of that room or suite does not exceed 50 feet.

The exit travel distances specified in items 1 and 2 above may be increased by fifty feet in buildings completely equipped with approved automatic sprinkler systems. No exit or exit access should contain a corridor, hallway, or aisle having a pocket or dead-end exceeding 50 feet for Use Conditions III and IV, and 20 feet for Use Condition V.

Aisles, corridors, and ramps required for access or exits shall be at least four feet in width (three feet wide for existing facilities). All means of egress from detention and correctional occupancies that traverse other use areas, such as courthouses, should as a minimum conform to the requirements for detention and correctional facilities.

EXIT MARKING AND EXIT ILLUMINATION

All exits should be identified by readily visible signs. Where access to exits is not easily visible to occupants, access routes should also be marked with suitable signs. However, exit signs may be omitted in sleeping room areas at horizontal exits and smoke partitions if desired. Exit marking should be provided in all areas accessible to the public.

Illumination of the means of egress should be continuous whenever the building is occupied. Illumination should include all access routes required to reach exits, the entire path within exits, and the point of exit discharge.

Emergency power is required for illumination of the means of egress and exit marking. Emergency lighting facilities should be arranged to maintain illumination for a period of one and one-half hours should normal lighting fail. The emergency lighting system should be arranged to provide the required illumination automatically in the event of interruption of normal lighting. The emergency lighting system should be continuously in operation or should be capable of repeated automatic operation without manual intervention.

INTERIOR FINISH MATERIALS

The initial growth of a fire may be significantly affected by materials used as interior finishes within a building. Combustible interior finish materials, such as foam plastic used for padding of cells, have been significant factors in multiple death fires. The relative hazard of any interior finish is usually judged on the basis of tests conducted in accordance with NFPA 255, *Method of Test of Surface Burning Characteristics of Building Materials*, commonly referred to as the Steiner Tunnel Test.

Interior finish of walls and ceilings in means of egress and any room or cell not separated from the means of egress by at least a one-hour separation should be Class A (Class B for existing facilities). All other areas should be at least Class C. Floor finish material in the means of egress in any room or cell not separated from the means of egress by at least a one-hour separation should be Class A (Class B in existing facilities).

In many occupancies it is considered reasonable to use a higher class material wall or floor finish in buildings equipped with an approved automatic sprinkler system. This practice is not considered prudent for detention and correctional facilities. Class C interior finish is permitted in existing facilities when sprinklers are installed.

Every building should be equipped with an electrically supervised, manually operated fire alarm system. When activated, the manual fire alarm system should be designed to sound an alarm throughout the facility which can be heard above ambient noise levels. The fire alarm system should be arranged to transmit an alarm automatically to the fire department. However, where the fire department is not equipped to receive such alarms, a different arrangement for notification of the fire department should be provided. Due to the nature of detention and correctional occupancies, the standard does permit the locking of manual fire alarm boxes or the location of manual fire alarm boxes at staff locations, provided there is twenty-four hour staffing and keys are readily available to unlock the boxes.

Automatic smoke detection systems should be provided in the following areas:

- a. All sleeping areas and areas not separated from sleeping areas by fire-resistive construction in Use Conditions IV and V.
- b. In sleeping rooms occupied by more than four persons in Use Condition III.
- c. In all corridors and common spaces in Use Conditions II and III.
- d. In corridors of all facilities protected by completely automatic sprinkler systems.

Smoke detectors may be arranged to alarm locally only and are not required to be connected to the fire department. All detection systems should be electrically supervised and should be provided with an alternate power supply from the emergency power system.

Due to the problem of tampering with detection devices, the code does permit alternate arrangements in positioning smoke detectors, provided the function of detecting a fire is fulfilled and the location of detectors is such that the speed of detection will be equivalent to that provided by standard spacing and arrangements. This may include the location of detectors in exhaust ducts from cells, behind grills, or in other locations. The equivalent performance of the design, however, should be acceptable to the authority having jurisdiction.

Automatic sprinkler systems that respond automatically to a fire condition provide detection, alarm annunciation, and suppression in one operation. The automatic sprinkler system has a proven record of life safety extending for nearly one hundred years. A person in contact with the fire origin may still be seriously threatened in a sprinkler environment; however, persons in adjoining spaces (in a number of recorded cases, persons within the room of fire origin), have been adequately protected against the effects of fire by automatic sprinklers. Sprinklers have been successfully installed in many detention and correctional facilities. For example, sprinklers are installed throughout the state prisons in Tennessee and in the New Hampshire State Prison. They were also installed in the St. John, New Brunswick detention center following the fatal fire there.

An automatic sprinkler system should be designed in accordance with NFPA 13, *Installation of Sprinkler Systems*. The automatic sprinkler system should automatically sound the building fire alarm and transmit an alarm to the fire department. The sprinkler system and components should be electrically supervised to ensure reliable operation. Electrical supervision should include gate valve tamper switches that provide a local alarm in a constantly attended location when the valve is

closed; supervision of fire pumps, if used, to include pump running; low system pressure and a loss of pump power; and supervision of water tanks, if used, to include low water alarm.

Protection of isolated areas where six or less sprinklers are required may be provided by connections to the building's domestic water supply system. The water supply should have proven hydraulic capability to provide not less than 0.15 gpm per square foot of floor area throughout the entire enclosed area. An indicating shut-off valve should be provided at an accessible location between the sprinklers and the connection to the domestic water supply. Water flow indication and alarm is recommended as is gate valve tamper supervision.

Complete, approved automatic sprinkler system protection should be provided throughout all detention and correctional facilities. However, buildings of fire-resistive construction of any height and buildings of protected noncombustible, protected ordinary, and protected wood frame construction not over two stories in height, are not required to be sprinklered.

Class III standpipe and hose systems should be provided for all buildings over seventy-five feet in height and all combustible buildings over two stories in height. Class II and III standpipe and hose systems should be provided for any building over three stories in height which does not have sprinklers. One inch diameter formed rubber hose may be used in lieu of one and one-half inch rubber lined hose required in NFPA 14, *Installation of Standpipe and Hose Systems*.

Portable fire extinguishers should be provided in all areas of the building. However, due to the problem of tampering, access to portable fire extinguishers may be locked or the portable fire extinguishers may be located in supervised staff locations only, provided there is twenty-four hour staffing and keys are readily available.

BUILDING SERVICE EQUIPMENT

Building service equipment should be installed and maintained in accordance with appropriate NFPA standards in order to minimize the probability of such equipment serving as a source of fire exposure to building occupants. Special consideration should be given to the design and installation of heating and air conditioning systems. Such systems shall be installed in accordance with NFPA 90A, *Air Conditioning and Heating Systems*. Portable heating devices are judged to be unsafe within detention and correctional facilities. Combustion and ventilation air for boilers, incinerators, or heater rooms, should be taken directly from and discharged directly to the outside. The heating system should have safety devices to immediately stop the flow of fuel and shut down the equipment in case of either excessive temperatures or ignition failure. Approved suspended unit heaters may be used in locations other than means of egress and sleeping areas, provided heaters are located high enough to be out of reach of persons using the area and are equipped with the safety devices.

Rubbish or linen chutes, including pneumatic rubbish and linen systems, should be provided with automatic sprinkler systems installed in accordance with NFPA 13. All trash chutes should discharge into a trash collecting room used for no other purpose and separated by one hour fire-resistive construction or protected by automatic sprinklers. Incinerators should not be directly fuel fed nor should any floor chute directly connect with the combustion chamber.

Each detention and correctional facility should have a fire safety and evacuation plan. This plan should be developed in cooperation with the staff and management of the detention and correctional facility as well as with the local fire department. All facility personnel should become familiar with this plan and should be continually drilled in its use. Training of personnel should include the use of fire extinguishers, the proper method of sounding an alarm, how to move inmates to an area of refuge, and how to operate all fire detection and alarm equipment.

Each facility should have a fire and safety officer whose prime responsibility is recognizing hazards, enforcing the emergency plan, liaison with the fire department, and training of personnel. This fire and safety officer should report directly to the prison administrator and have his support in correcting fire protection deficiencies. This person should also have the freedom to actively work with the local fire department to arrange inspection tours and mutual training exercises. It is extremely important that the fire department be familiar with the construction and fire protection details of the detention and correctional facility.

Emergency drills should include transmission of fire alarm signals and simulation of emergency fire conditions to the extent possible without jeopardizing the well-being of occupants. This may require some coordination and planning in a detention and correctional facility. If drills are not conducted during times of normal operation, it cannot be expected that orderly and rapid evacuation of the facility can be accomplished during times of emergency. Drills should be conducted on all three shifts and at different times of the day. The use of the building alarm equipment during drills provides an operating test of the equipment and also familiarizes people with the operation and sound of the fire alarm devices.

The fire safety and evacuation plan should include as a minimum the following fundamentals:

- Training in the use of fire alarm and fire detection equipment.
- Transmission of the alarm to the fire department. This is an important function and should be planned ahead of time with the fire department.
- Evacuation practices for all areas.
- Use of fire extinguishers.
- Use of alternate evacuation routes in case the primary routes are not available.
- Assisting the fire department in the timely entrance into the site and clearing of equipment and personnel.
- The cooperation of local police in control of inmates if they are to be evacuated to the outside.

Appendix C

GLOSSARY

ambient temperature: The temperature of the surrounding environment. For example, the ambient temperature of the room in which you are now seated may be 68°F (20°C).

area of refuge: An area to which occupants can be evacuated that is safe from the effects of fire. An area of refuge can be the exterior of the building, another building, or another area of the same building that is separated by fire resistant construction. The minimum fire resistance rating of a wall separating an area of refuge should be 2 hours.

automatic sprinklers: Devices for automatically distributing water upon a fire in sufficient quantity either to extinguish it entirely or to prevent its spread in the event that the initial fire is out of range of the sprinklers or is a type that cannot be extinguished by water discharged from sprinklers through a system of piping, ordinarily overhead, with the sprinklers placed at intervals along the pipes. Sprinklers normally go off individually and only when they are in close proximity to the fire.

building materials: In general, any material used for the construction of a building. In the context of this manual, building materials refer to the structural portions of the building, and are separate from interior finish. In areas where the structural elements of the building are exposed, the building material may in fact also be the interior finish.

capacity per unit of width: The capacity in number of persons per unit of exit width for approved components of means of egress.

carboxyhemoglobin: The blood-gas mixture which results from carbon monoxide combining with the hemoglobin in the blood (hemoglobin is the oxygen-carrying part of the blood).

combustibles: Materials which can burn, for example, wood, cloth, paper, and synthetics such as polyurethane foam and styrene-butadiene foam.

compartmentation: The concept of retarding fire growth, development, and spread with fire resistant walls, ceilings, and floors. In order for the compartmentation to be effective, all openings in the fire resistant members must be protected with fire resistant doors, windows, or other enclosures.

component: In its simplest meaning, a component is one of the constituent parts or elements that make up a complex whole. Within the context of a system, a component performs a specific function and has the potential to interact with other components of the system. For example, each box of the Fire Safety Concepts Tree (whether it be termed a goal or a method) can be thought of as a component.

contents/furnishings: Those articles such as furniture, books, draperies, contained within a structure which tend to increase comfort or utility and which are generally not secured in place.

defend in place: The concept of providing a safe environment for occupants during a fire incident to an extremely high degree of reliability. In a defend-in-place occupancy, only the room of fire origin has to be evacuated. The technology does not exist, in a realistic and cost effective manner, to protect the person or persons directly involved with ignition, such as an individual that is smoking in bed. Defend in place occupancies utilize fire protection equipment such as automatic sprinklers, smoke detectors, and smoke control systems.

early warning detection: Detection equipment that will detect a fire and sound an alarm very early in the fire development. Smoke detectors are the most common type of early warning detection; however, there are other types of early warning detection equipment, such as heat and flame detectors.

emergency operating procedures: An emergency plan for fire fighting operations at designated properties or locations. Emergency operating pro-

cedures generally include evacuation plans and responsibilities of staff and fire brigade (e.g., operation of standpipe and hoses, and notification of the fire department).

energized equipment: Refers to electrical equipment, appliances, or devices that are live electrically.

eutectic metal: The mixture, or alloy, of two or more metals that gives the lowest melting point possible. For most alloys the melting point of the eutectic is a sharply defined temperature and, thus, well suited for use in fusible-link automatic sprinklers.

exit: That portion of a means of egress which is separated from all other spaces of the building or structure by construction or equipment to provide a protected way of travel to the exit discharge.

exit access: That portion of a means of egress which leads to an entrance of an exit.

exit discharge: That portion of a means of egress between the termination of an exit and public way.

failure mode: The way in which a system has failed to achieve the desired results. For example, if an automobile runs out of fuel, the engine fails to run and the desired objective (driving down the street) is not met. The failure mode would be running out of fuel.

feedback: The return to a point of origin (to the input stage of a system) of evaluative or corrective information about an action or process. For example, "pinging" or the sound of predetonation of the gasoline-air mixture in the combustion chamber of an engine can be thought of as feedback. This noise tells the driver of the car to increase the octane of the gasoline, shift to a lower gear, tune the engine, or all three.

fire brigade: The fire service organization of an industrial plant or private institution as distinguished from the public fire department. The American industrial or private fire brigade may vary in strength from a squad to several hundred members who may be fully-paid, paid on call, or unpaid volunteer fire fighters.

fire door : A door that has a specific fire protection rating, as tested by nationally recognized testing laboratories, and is suitable for protecting either vertical or horizontal openings in walls, floors, or ceilings. Openings are classified accord-

ing to NFPA 80, *Standard for the Installation of Fire Doors and Windows*, as A, B, C, D, and E in accordance with the character and location of the wall in which they are situated. The suitability of a fire door should be judged on the class of opening in which it is to be installed. There are several types of construction for fire doors including composite doors, hollow-metal, metal-clad, and sheet-metal doors.

fire hose: Hose used for fire fighting purposes. Fire hose can be made in several ways. The most common are rubber lined and coated, unlined, single jacket rubber lined, double jacket rubber lined, and hard suction rubber. One and one-half inch and 2½ inch are the most common sizes.

fire partition: An interior wall, one story or less in height, that separates two areas. It serves to restrict the spread of fire, but does not qualify as a fire wall.

fire resistance: A relative term often used with a system of rating to indicate the extent to which a material or structure resists the effects of fire, for example, two hours fire resistance as measured on the standard time-temperature curve.

fire-resistive: The property or design of a structure or assembly of materials built to provide a predetermined degree of fire resistance. Building and fire prevention codes usually call for construction capable of 1-hour, 2-hour, or 4-hour fire resistance. "Fireproof" is often used incorrectly instead of fire-resistive. In reality, nothing is "fireproof."

fire wall: A fire wall may be broadly defined as a wall erected to prevent the spread of fire. To be effective, fire walls must have sufficient fire resistance to withstand the effects of the severest fire that may be expected to occur in the building and must provide a complete barrier to the spread of fire. Any openings in a fire wall must be suitably protected.

fire window: A window assembly, including frame, wired glass, and hardware which, under NFPA 257, *Standard for Fire Tests of Window Assemblies*, meets the fire protective requirements for the location or class of opening in which it is to be used.

flame spread: The rate at which flames spread over surfaces of various materials such as interior finishes, fabrics, etc.

flashover: The sudden and dramatic simultaneous ignition of most combustible materials and gases in a room or area. Flashover occurs when room temperatures near the ceiling rapidly rise to 800° — 1,200°F. The time between the ignition of fire in a room and flashover is critical to the safe evacuation of occupants from the room and to effective rescue and suppression operations.

fuel configuration: In the sense in which it is used in this manual, fuel configuration refers to fuel as either natural (cellulosic) or synthetic.

Halon: Refers to any one of the halogenated extinguishing agents, for example Halon 1211 or Halon 1301.

hazard of occupancy: A condition of fire potential defined by arrangement, size, type of fuel, and other factors which form a special threat of ignition or difficulty of extinguishment in an occupancy.

heat detector: Heat detecting devices fall into two general categories: (1) those that respond when the detection element reaches a predetermined temperature (fixed-temperature types), and (2) those that respond to an increase in heat at a rate greater than some predetermined value (rate-of-rise types). Some devices combine both the fixed-temperature and rate-of-rise principles.

hose cabinet: A cabinet that can be flush or surface-mounted on a wall that contains hose for fire fighting purposes. Many times additional equipment, such as portable fire extinguishers, can be placed in the hose cabinet. Hose cabinets are available with plain steel doors, plain glass doors, or break-glass doors. The break-glass doors can usually be kept locked and in a fire situation the glass can be broken so that access can be gained.

HVAC system: An acronym for a heating, ventilating, and air conditioning system.

incendiary, suspicious: All fires that are known or thought to have been set, whether to defraud insurance companies, by mentally ill persons, or by malicious persons.

input: Information, resources, raw data, or material that is put into a system. For example, manpower and money can be regarded as input for many systems.

interior finish: The exposed interior surfaces of buildings including, but not limited to, fixed or movable walls and partitions, columns, and ceilings.

ionize: To convert atoms or groups of atoms into a state of having an electric charge. In the case of the ionization detector, ionizing the air makes the air electrically conductive.

listed: Equipment or materials included in a list published by a nationally recognized testing laboratory, inspection agency, or other organization concerned with product evaluation, that maintains periodic inspection of production of listed equipment or materials and whose listing states either that the equipment or material meets nationally recognized standards or has been tested and found suitable for use in a specific manner.

low density fiberboard: A ceiling and wall material made of compressed and finely divided wood fibers. This material has an extremely high flame spread and has been responsible for many fire deaths due to the rapid flame spread over its surface. Painting the surface of low density fiberboard with a fire retardant paint is not an adequate solution to the flame spread problem.

margin of safety: Represents the additional time given to occupants where automatic detection and alarm systems are employed rather than manual detection and alarm systems.

means of egress: A continuous and unobstructed way of exit travel from any point in a building or structure to a public way and consisting of three separate and distinct parts: (a) the way of exit access, (b) the exit and, (c) the way of exit discharge. A means of egress comprises the vertical and horizontal ways of travel and shall include intervening room spaces, doorways, hallways, corridors, passageways, balconies, ramps, stairs, enclosures, lobbies, escalators, horizontal exits, courts, and yards.

neoprene: A chlorinated synthetic polymer that has many properties similar to natural rubber. Neoprene also has the advantage of being resistant to sunlight, ozone, oxidation, oil, and heat. Neoprene compounds have high abrasion resistance, tensile strength, and elasticity. Neoprene is used in transmission belting, insulation, shoe soles, and extensively in foam cushioning in upholstered furnishings. Specially treated neoprene foams show great promise in resisting

flaming ignition sources. This quality makes furnishings, especially mattresses, made with neoprene foams advantageous for use in correctional facilities.

obscuration: A quantity measured by the Steiner Tunnel Test that refers to the smoke density or amount of smoke developed and is an indication of the degree of reduced visibility when specific materials are burned.

occupancy: The purpose for which a building or portion thereof is used or intended to be used.

occupant use hose: One and one-half-inch fire hose that is used by occupants for fire fighting purposes. Occupant use hose can be unlined or lined with rubber and usually has a textile outer covering. Occupant use hose is frequently stored in hose cabinets, although it can be stored on exposed racks. In some cases, occupant use hose can be stored on a reel that is played out as needed.

output: That which is actually produced by the process of the system. The output can be mechanical energy, as in the example of a car engine which is connected to the drive train, or the suppression of an incipient fire by an automatic sprinkler system. Output should not be confused with goal which represents the *expected* output of the system.

photoelectric: The principle whereby a substance, for example, smoke, enters a light beam and obscures the beam's path into a photoelectric cell. In the case of a photoelectric smoke detector, partial obscuring of the beam trips the alarm.

polyvinyl chloride (PVC): This type of plastic is made as a rigid product for a number of building components and as a flexible plasticized stock for upholstery and wearing apparel. It exists in hundreds of individual formulations. It has good abrasion resistance. The unplasticized PVC softens as it burns, and produces white smoke and acrid fumes which can be corrosive. Most of the chlorine content is released as hydrogen chloride. The fire properties of plasticized PVC are determined to a large extent by the nature of the plasticizer. Building products should be tested individually.

portable fire extinguishers: First aid fire fighting appliances that can be easily moved about and used for extinguishing small fires. The equipment generally consists of a pressure vessel of some sort that contains an extinguishing agent. The devices are

classified according to the type of fires they can extinguish. Class A type fires are those involving ordinary combustibles such as wood, paper or textiles. Class B fires are those involving flammable liquids. Class C fires are those involving charged electrical equipment, and Class D fires are fires occurring in certain combustible metals. Portable fire extinguishers can be rated to be used on more than one type of fire. Typical types of extinguishers are pressurized water (Class A), carbon dioxide (Classes B and C), regular dry chemical (Classes B and C), multipurpose dry chemical (Classes A, B, and C).

protective signaling systems: Systems, both automatic and manual, that are installed for fire protection purposes. Protective signaling systems can be as simple as the familiar fire alarm boxes which summon organized assistance for fighting a fire or as complex as a proprietary system which may supervise and actuate fire extinguishing systems in several buildings as well as notify the fire department.

self-closing door: A door equipped with an approved device which will insure closing after the door is opened.

self-contained breathing apparatus (SCBA): Respiratory equipment that has self-contained oxygen or air necessary for survival in atmospheres deficient in oxygen or laden with toxic gases. Generally, there are three types of SCBA's: the open-circuit "demand" or "pressure-demand" type, the closed-circuit system equipped with a cannister and a breathing bag, and the closed-circuit oxygen rebreathing system.

smoke control: The concept of controlling and confining the spread of smoke in building fires. This concept is particularly important in fires involving high-rise buildings and defend-in-place occupancies. Smoke control can be achieved by controlling fuel, rapid fire suppression, or involving the use of smoke barriers, ventilation, pressurization, or a combination of these.

smoke detector: A device which senses visible or invisible particles of combustion.

software: The set of programs, procedures, and related documentation associated with a system. In this manual, software refers more specifically to educational and training programs, emergency operating procedures, and plans.

standpipe and hose: According to NFPA 14, *Installation of Standpipe and Hose Systems*, "a

standpipe system is an arrangement of piping, valves, hose outlets and allied equipment installed in a building or structure with outlets located in such a manner that water can be discharged in streams or spray patterns through hose and nozzles, attached to such hose outlets, for the purpose of extinguishing a fire and so protecting a building or structure and its contents in addition to protecting the occupants." First aid standpipes for use by building occupants are provided with 1½-inch hose and small nozzles and are under domestic or private water pressure. Fire department standpipes have 2½-inch hose outlets.

styrene-butadiene rubber (SBR) foam: Is the true "foam rubber" that has been used in the past. This material is different from foam plastic, which is most often polyurethane foam. SBR is a synthetic latex-type foam that has poor fire characteristics. Among these characteristics are intense burning and massive smoke generation. SBR foam is not in widespread production in the United States; however, there is still a great deal of the material in existence. SBR foam was used as the padding material in both the St. John, New Brunswick Detention Center fire which took 21 lives and the Maury County Jail fire which took 42 lives.

subsystem: A secondary or subordinate system of the "total" system. For example, an automatic sprinkler system can be looked at as a subsystem of the Simplified Fire Safety System.

system: The organization of interacting components in such a way as to carry out a predetermined function or reach a specified goal. A system can be as complex as an educational system or as concrete as the engine of an automobile. In all instances, however, a system must be interactive, dynamic, and identifiable.

trade-off: Refers to the concept of equal protection by allowing less restrictive code requirements in some areas for providing a greater amount of fire protection. For example, NFPA 101, *Life Safety Code*, permits travel distances to be 50 percent longer in some instances if sprinkler protection is provided.

untenable: Refers to a state in which conditions of fire have made a room or area too dangerous to be occupied and defended.

urethane (polyurethane): The polyurethanes consist of a group of polymers which are produced in the following general forms: foams (flexible, semi-flexible, and rigid); elastomers (casting compounds); and elastoplastic resins, adhesives, coatings, and spandex fiber. The basic reaction used to produce the urethane polymers involves isocyanates and reactive hydrogen-bearing materials such as polyethers, castor oils, amines, carboxylic acid, and water. By varying the number of branchings, it is possible to make polyurethanes that are thermoplastic or thermosetting.

BIBLIOGRAPHY

- ANSI/ASTM E 84-79a *Test for Surface Burning Characteristics of Building Materials*. Philadelphia: American Society for Testing and Materials, 1979.
- Bell, J.R. "Investigation Report, Lancaster County Jail, Lancaster, South Carolina." Unpublished Report, National Fire Protection Association, 1980.
- Best, R.L. "Seven Die in Gas Explosion at a Penitentiary Farm Building," *Fire Journal*, Vol. 73, No. 3 (May 1979), 25-28.
- DiMeo, M.J. "Where There Are No Emergency Exits," *Fire Command*, Vol. 43, No. 8 (August 1976), 46-49.
- Drucker, Peter F. *Management: Tasks, Responsibilities, Practices*. New York: Harper & Row, 1973.
- Egan, M. David. *Concepts in Building Firesafety*. New York: John Wiley & Sons, Inc., 1978.
- Fire Safety Bulletin on Penal Institutions*. Boston: National Fire Protection Association, 1977.
- Flammability Standard for Mattresses (FF4-72)*. Washington: Department of Commerce, June 1973.
- Hartson, C. and Rickey, G. "Ohio's Institutional Firesafety Program," *Fire Command*, Vol. 46, No. 3 (March 1979), 34-35.
- Martino, R. L. *Applied Operational Planning*, Vol II. New York: American Management Association, 1964.
- McKinnon, Gordon P. (ed.) *Fire Protection Handbook*, 14th. ed. Boston: National Fire Protection Association, 1976.
- Miller, E. Eugene. *Jail Management: Problems, Programs, and Perspectives*. Lexington, MA: D.C. Heath and Co., 1978.
- NFPA 101, *Life Safety Code*. Boston: National Fire Protection Association, 1976.
- NFPA 255, *Method of Test of Surface Burning Characteristics of Building Materials*. Boston: National Fire Protection Association, 1972.
- NFPA 13, *Standard for the Installation of Sprinkler Systems*. Boston: National Fire Protection Association, 1978.
- NFPA 10, *Standard for Portable Fire Extinguishers*. Boston: National Fire Protection Association, 1978.
- NFPA 220, *Standard on Types of Building Construction*. Boston: National Fire Protection Association, 1975, 1979.
- Pryor, A.J. "Full Scale Fire Tests of Interior Wall Finish Assemblies," *Fire Journal*, Vol 63, No. 2 (March 1969), 14-20.
- Report No. NBSIR-77-1290, "Combustion of Mattresses Exposed to Flaming Ignition Sources/Part I - Full Scale Tests and Hazard Analysis." Washington: National Bureau of Standards, 1977.
- Smith, E.E. "Measuring Rate of Heat, Smoke, and Toxic Gas Release," *Fire Technology*, Vol. 8, No. 3 (August 1972), 237-245.
- A Study of Penal Institution Fires*, NFPA No. FR78-1. Boston: National Fire Protection Association, 1977.
- Sumi, K. and Tsuchiya, Y. "Toxic Gases and Vapors Produced at Fires," *Fire Service Information* (Iowa State University Bulletin), Vol. 5, No. 1 (February 1974), 4-6.
- The Systems Approach to Fire Protection*, a compilation of articles from *Fire Journal* and *Fire Technology* (NFPA No. SPP-36). Boston: National Fire Protection Association, 1976.
- Waksman, D. and Ferguson, J.B. "Fire Tests of Building Interior Covering Systems," *Fire Technology*, Vol. 10, No. 3 (August 1974), 211-220.

Appendix E

CHAPTER REVIEW ANSWER KEYS

CHAPTER ONE

1. During the 1960s and 1970s, synthetic fuels were replacing ordinary combustibles as the primary fuels involved in fires.
2.
 - a. type of act
 - b. fuel type
 - c. place of origin
 - d. problems in evacuation
3. b
4. d

CHAPTER TWO

1. A system is the organization of interacting components in such a way as to carry out a predetermined function or reach specified objectives.
2.
 - a. interactive
 - b. dynamic
 - c. identifiable
3. b
4. input process output feedback
5.
 - a. Provides an organized way of looking at a problem.
 - b. Incorporates all significant, interacting components when it attempts to look at a problem.
 - c. Provides a means to determine the most cost-effective solution.
6. The Fire Safety Concepts Tree represents a systems approach to building fire safety derived through a decision tree network.

7. b, c, d, e

8. Objectives:
Life Safety
Property Protection
Limited Downtime
Security

Gate: dot within a circle

Goals:
Ignition Control
Fuel Control
Occupant Protection
Detection and Suppression Activities
Planning and Training Operations

9. Fire safety must be maintained without jeopardizing the loss of inmates through escape, suicide, murder, or related security problems.

CHAPTER THREE

1. Ignition control is the concept of eliminating uncontrolled heat sources so that a fire cannot be ignited either accidentally or intentionally.
2. a
3. Whether accidental or deliberate, all fires involve the human error factor which is not easily controlled.
4.
 - a. Control smoking materials.
 - b. Control electrical ignition sources.
 - c. Use alternate grievance mechanism.
5. Through this mechanism inmate inmates can express their complaints without resorting to the setting of fires for recognition.

6. b
7. a
8. Open flame ignition source: Use of self extinguishing matches or use of wall-type cigarette lighters.
Smoldering ignition source: Use of specially constructed polyurethane mattresses.
9. b
10. Inmates' rights and inmate behavior (disturbing the routine).

CHAPTER FOUR

1. Fuel control is the concept of controlling the type, arrangement, and burning characteristics of potential fuels.
2. One must assume that fires will be started either accidentally or deliberately and take steps to control the potential fuels.
3. d
4. Contents or furnishings: Cotton mattresses treated with boric acid or treated polyurethane mattresses
Building materials: Fire-resistive construction
Interior finish: Use low-flame spread rated materials
5. S polyurethane
S nylon
N cotton
S styrene-butadiene
N wood
S neoprene
S polyvinylchloride
6. Synthetic materials release twice as much heat per pound, and at a rate 5 to 100 times as great.
7. NS carbon dioxide (CO₂)
S hydrochloric acid (HCl)
NS carbon monoxide (CO)
8. d
9. b
10. Fire-resistive

11. Unprotected structural members may be damaged by heat; combustible materials used for other purposes can spread fire.
12. a, b, d
13. Flashover is usually defined as the sudden and dramatic simultaneous ignition of most combustible materials in a room or area.
14. This time affects the evacuation of room occupants.
15. The Steiner Tunnel Test is used to classify interior finishes according to their flame spread and smoke development.
16. b
17. Living Quarters: That inmates are entitled to a humane environment has resulted in the use of interior finishes with poor burning characteristics.

Personal Comfort: Polyurethane and styrene-butadiene foam rubber mattresses provide more comfort but are more toxic in a fire situation.

Recreation and Education: Increased numbers of books and other forms of entertainment have significantly increased fuel load in cells.

CHAPTER FIVE

1. Occupant protection is the concept of providing life safety in the event of fire either by evacuation to a secure area or by defending in place.
2. a. evacuate to another secure area of refuge
b. reliably defend in place
3. a, b, c, d
4. c, e
5. NFPA 101, *Life Safety Code*
6. Refer to diagram on page 63.
7. The addition of sprinklers allow the required travel distance to be increased up to 50 percent.

- | | |
|--|---|
| <p>8. Exits should be remote from each other so that they cannot readily be blocked by a single fire.</p> <p>9. a. A continuous path to a safe area for the duration of the fire.
b. Adequate capacity.
c. Routes safe from intrusion by fire during evacuation.
d. Availability at all times.</p> <p>10. Reliable power source independent from the normal building service.</p> <p>11. Walls, ceilings, floors.</p> <p>12. A fire wall normally extends through the roof; a fire partition extends from one floor to the underside of another.</p> <p>13. b</p> <p>14. Fire doors are the most widely used and accepted means for the protection of both vertical and horizontal openings.</p> <p>15. 3. a
1. b
2. c</p> <p>16. a. locking
b. unlocking
c. door movement open
d. door movement closed</p> <p>17. a. mechanical
b. manual
c. electro-manual
d. electro-mechanical
e. electric pneumatic</p> | <p>4. c</p> <p>5. For manual systems there is a definite lapse from the time the fire is detected until the alarm is sounded, and again until there is a response to the alarm.</p> <p>6. a, b, c</p> <p>7. a. peer pressure
b. ease of vandal identification
c. personal discomfort</p> <p>8. b</p> <p>9. a. heat
b. smoke
c. flame</p> <p>10. a. photoelectric or ionization-type smoke detector
b. flame detectors</p> <p>11. a. Notify occupants so they can evacuate the area.
b. Summon organized assistance to assist in fighting the fire or supervising extinguishing systems to assure their operability.</p> <p>12. Evacuation alarms may cause panic among occupants of facilities who may not be able to initiate self-preservation activities.</p> <p>13. a. portable extinguishers
b. standpipe and hose systems
c. sprinklers
d. hydrants
e. self-contained breathing apparatus</p> <p>14. a. The kind of materials or the class of fire they would extinguish.
b. The potential severity of fire.
c. The capability of people using the extinguishers and the extinguishers' relative "fire-killing" power.
d. The particular extinguishing agent they contain.
e. Their propellant system.</p> <p>15. 4. a
3. b
1. c
2. d</p> |
|--|---|

CHAPTER SIX

1. Detection and suppression activities involve the concept of automatically or manually detecting the presence of a hostile fire, sounding an alarm, and then extinguishing the fire.
2. a. detection
b. alarm
c. suppression
3. b, c, d

16. A 4-A extinguisher would be used on ordinary combustibles.
A 20-A extinguisher would have five times the potential for extinguishing effectiveness.
17. A 5-B:C extinguisher could be used on fires involving flammable liquids as well as energized electrical equipment.
18. The disadvantage of all water-base extinguishers is freezing.
19. a, b, c, d, e, f
20. a, b
21. open-circuit "demand" or "pressure-demand"
22. Refer to the diagram on page 96.
23.
 1. a
 2. b
 3. c
24. b
25.
 2. a
 1. b
26. c
27. Properly installed and maintained automatic sprinklers offer the highest assurance of safety to life from fire. They give a sense of security to occupants of buildings and minimize the possibility of panic.
28. a
29.
 - a. wet pipe systems
 - b. dry pipe systems
 - c. preaction systems
 - d. deluge systems
30. b
31. a
32. c
33.
 - a. Maintain constant water supply.
 - b. Keep valves open until the fire is out.
 - c. Limit length of time system is out of service for maintenance.

- d. Assure complete protection through coverage in all areas.
- e. Avoid obstructions.
- f. Protect against freezing.
- g. Assure dependable operating condition of all parts.

CHAPTER SEVEN

1. Planning and training operations constitute the concept of planning emergency operating procedures and conducting training activities.
2. b
3. a, b, d
4. Planning and training operations help reach life safety in particular and, also, property protection, security, and limited downtime.
5. a, c, g
6. c
7. The effectiveness of a fire safety program for a facility is maximized by tailoring the program to the individual facility.
8. a, d
9.
 - a. history of the problem
 - b. hazards of fire
 - c. available fire protection technology
 - d. emergency operating procedures
 - e. potential problem
10. b, g
11.
 - a. Calling the fire department.
 - b. Safeguarding lives.
 - c. Providing manual suppression to control the fire until the fire department arrives.
 - d. Protecting equipment.
12.
 - a. Fire fighting with portable extinguishers.
 - b. Using hose lines.
 - c. Venting of buildings.
 - d. Performing related rescue operations.

13. The purpose of an emergency operating plan is to provide a guide for evaluating the particular problems at hand and for coordinating the response of the fire brigade and fire department as well as the action of staff and inmates.
14.
 - a. simple
 - b. comprehensive
 - c. specific
 - d. flexible
 - e. workable
15. Representatives from management (for example, the warden or assistant warden), staff, inmates, and fire brigade members; in addition, representatives of the local fire department and law enforcement agencies.
16. Step 1: Define the potential fire protection problems in the particular correctional facility.
 Step 2: Set objectives for the plan.
 Step 3: Determine the capability of the facility for controlling an emergency situation.
 Step 4: Define the roles of the responding agencies, especially the fire department and the fire brigade.
 Step 5: Put the information into written form.

CHAPTER EIGHT

1. a, b, c, e
2. LR Manpower
 SR Development of an emergency operating plan
 SR Inspection procedures
 LR Purchase of major apparatus
 SR Purchase of SCBA's

- LR Fire safe building construction
- LR Installation of automatic sprinklers
- SR Staff and inmate education and training

3.
 - a. life safety
 - b. property protection
 - c. downtime
 - d. security
4.
 - a. financial constraints
 - b. operational constraints
 - c. technical constraints
5. mileposts or intermediate steps
6. The term "comprehensive" represents the transfer of learning about the Simplified Fire Safety System to putting the entire system to work.
7. It is the function of management to determine time, money, and resources and to select which options will be chosen in implementing the plan.
8.
 - a. Phase I: Define the intent of the plan.
 - b. Phase II: Define the goals of the plan.
 - c. Phase III: Define methods for achieving each goal.
 - d. Phase IV: Identify tasks to fulfill each method.
 - e. Phase V: Determine specific steps needed to carry out each task.
9.
 - a. ignition control
 - b. fuel control
 - c. occupant protection
 - d. detection and suppression activities
 - e. planning and training operations
10.
 - a. Lack of technical expertise in the area of fire protection.
 - b. Lack of funding.