

50336

**NBS Special
Publication
480-34**

**Test Method for
the Evaluation
of Metallic
Window Foil for
Intrusion Alarm
Systems**



**Law Enforcement
Equipment
Technology**

50336^{ci}

**U.S. DEPARTMENT OF
COMMERCE
National Bureau of
Standards**

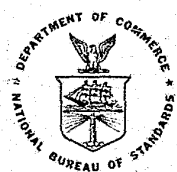

MICROFICHE

ACKNOWLEDGMENTS

This document was prepared by the Law Enforcement Standards Laboratory of the National Bureau of Standards under the direction of Lawrence K. Eliason, Manager of the LESL Security Systems Program, and Jacob J. Diamond, Chief of LESL. The research was sponsored by the National Institute of Law Enforcement and Criminal Justice, Lester D. Shubin, Program Manager for Standards.

NBS Special
Publication
480-34

Test Method for the Evaluation of Metallic Window Foil for Intrusion Alarm Systems

by

Gerard N. Stenbakken
Electrosystems Division

and the

Law Enforcement Standards Laboratory
Center for Consumer Product Technology
National Bureau of Standards
Washington, D.C. 20234

prepared for
National Institute of Law Enforcement
and Criminal Justice
Law Enforcement Assistance Administration
U.S. Department of Justice
Washington, D.C. 20531

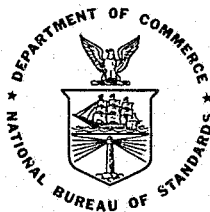

Issued August 1978

U.S. DEPARTMENT OF COMMERCE, Juanita M. Kreps, *Secretary*
Dr. Sidney Harman, *Under Secretary*
Jordan J. Baruch, *Assistant Secretary for Science and Technology*
NATIONAL BUREAU OF STANDARDS, Ernest Ambler, *Director*

Library of Congress Catalog Card Number: 78-600067

National Bureau of Standards

Special Publication 480-34

Nat. Bur. Stand (U.S.), Spec. Publ. 480-34; 10 pages

CODEN: XNBSAV

U.S. GOVERNMENT PRINTING OFFICE

WASHINGTON: 1978

For sale by the Superintendent of Documents,
U.S. Government Printing Office, Washington, D.C. 20402
Stock Number 003-003-01961-5. Price 90 cents.
(Add 25 percent additional for other than U.S. mailing)

FOREWORD

The Law Enforcement Standards Laboratory (LESL) of the National Bureau of Standards (NBS) furnishes technical support to the National Institute of Law Enforcement and Criminal Justice (NILECJ) program to strengthen law enforcement and criminal justice in the United States. LESL's function is to conduct research that will assist law enforcement and criminal justice agencies in the selection and procurement of quality equipment.

LESL is: (1) Subjecting existing equipment to laboratory testing and evaluation and (2) conducting research leading to the development of several series of documents, including national voluntary equipment standards, user guides, and technical reports.

This document is a law enforcement equipment report developed by LESL under the sponsorship of NILECJ. Additional reports as well as other documents are being issued under the LESL program in the areas of protective equipment, communications equipment, security systems, weapons, emergency equipment, investigative aids, vehicles and clothing.

Technical comments and suggestions concerning this report are invited from all interested parties. They may be addressed to the author or to the Law Enforcement Standards Laboratory, National Bureau of Standards, Washington, D.C. 20234.

Jacob J. Diamond, *Chief*
Law Enforcement Standards Laboratory

CONTENTS

	Page
Foreword	III
1. Introduction	1
2. Test Equipment	1
2.1 Glass Panels	1
2.2 Glass Cutter	2
2.3 Break Fixture	2
2.4 Ohmmeter	2
3. Sample Preparation	3
4. Breaking Procedure	4
5. Evaluation Procedure	5

TEST METHOD FOR THE EVALUATION OF METALLIC WINDOW FOIL FOR INTRUSION ALARM SYSTEMS

Gerard N. Stenbakken

Electrosystems Division, National Bureau of Standards, Washington, D.C. 20234

A test method has been developed for the evaluation of metallic foil used in intrusion alarm systems as a sensor to detect the breakage of glass. Laboratory tests have demonstrated that metallic window foil does not necessarily break when the glass upon which it is installed is broken. A detailed test procedure as well as criteria for the interpretation of the test results are presented.

Key words: Alarm systems; burglar alarms; glass breakage detectors; intrusion alarm sensors; metallic window foil; window foil.

1. INTRODUCTION

Metallic foil is frequently used in intrusion alarm systems as a sensor to detect the breakage of glass in windows, doors, and display cases. The systems are designed so that breakage of the foil will cause the initiation of a local audible alarm, or the transmission of an alarm signal to a police station or a central alarm station. The foil is attached to the glass surface by means of an adhesive, sometimes precoated on one side of the foil, and is connected to the rest of the alarm circuit through terminal blocks. The alarm system control unit monitors the flow of electrical current through the foil and initiates an alarm signal if the current is interrupted.

The two performance attributes of metallic foil, totally under the control of the manufacturer, that determine whether it is suitable for use as an alarm sensor are: 1) its current carrying capacity, and 2) the manner in which the foil breaks when the glass to which it is attached is broken. The reliability of metallic foil as an alarm sensor is also influenced by the manner in which the installer attaches it to the glass and the quality of its electrical connection to the rest of the alarm circuit, factors not under the control of the manufacturer.

A test procedure for the evaluation of the breaking characteristics of metallic foil has been developed and is presented below. The procedure has been used to determine whether metallic foil, adhesive bonded to glass in accordance with the manufacturer's instructions, would consistently generate an alarm signal when the glass was broken. A surprising number of metallic foil samples failed to break when the glass was broken, and would, therefore, not be suitable for use as an alarm sensor. The current carrying capacity of metallic foil was found, in all cases, to be consistent with normal alarm system requirements and was not addressed further.

2. TEST EQUIPMENT

The evaluation of the breaking characteristics of metallic foil requires the following test equipment.

2.1. Glass Panels

The glass test panels consist of plate glass 30 by 35 cm (12 by 14 in). The thickness of each panel should be between 0.52 and 0.55 cm (0.20 and 0.22 in), as determined by measurements made near the edge of the panel at the approximate midpoint of each of the four sides.

2.2. Glass Cutter

The glass cutter should have a tungsten carbide wheel, and visual examination of scribe marks made with the cutter should show no chipping of the glass surface.

2.3. Break Fixture

The break fixture, shown in figure 1, consists of two flat platforms, each approximately 20 by 40 cm (8 by 16 in), mounted on a common base approximately 40 by 40 cm (16 by 16 in). One platform is 1.25 ± 0.05 cm (0.5 ± 0.02 in) higher than the other. The inside edge of the higher platform, which forms the break edge of the fixture, should be made of a metal such as aluminum or steel. The remaining parts of the fixture can be made of any convenient material such as wood, metal or plastic. The surfaces of the two platforms should be sufficiently parallel that a straight edge placed anywhere on the upper one, as shown in figure 1, is 1.25 ± 0.05 cm (0.50 ± 0.02 in) above the lower one at a distance of 15 cm (6 in) from the break edge.

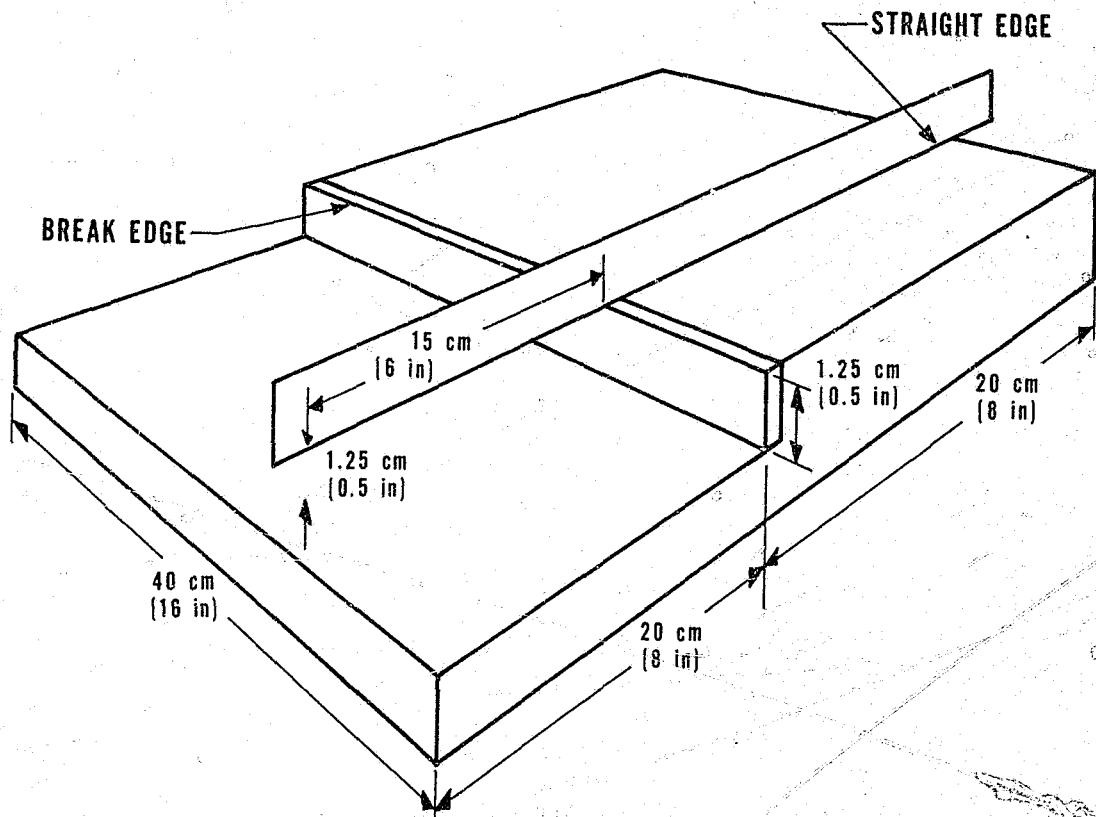

FIGURE 1. Break fixture.

2.4. Ohmmeter

The ohmmeter should have a center scale reading between 100 k Ω and 1.0 M Ω and measure a resistance of 100 k Ω with a maximum uncertainty of ± 6 percent.

3. SAMPLE PREPARATION

Use the glass cutter to scribe a line across the 30 cm (12 in) width of each glass test panel to be used. Normally, eight panels should be prepared for each sample of metallic foil that is to be evaluated. The scribe line should be distinct, continuous, and show no evidence of chipping of the glass surface. The scribe line should be parallel to and 15.0 ± 0.2 cm (6.0 ± 0.1 in) from one end of the glass test panel, as shown in figure 2.

Thoroughly clean both sides of each scribed glass panel with a mild soap solution and completely rinse it with clean water. Then clean each panel with methanol applied with a lint-free cloth and dry it with another lint-free cloth. Use caution throughout the cleaning process to prevent oil from the fingers or other sources from getting onto the glass.

Apply a 30 cm (12 in) length of 2 cm ($3/4$ in) wide cellulose acetate pressure sensitive adhesive tape to the unscribed surface of each glass test panel, directly opposite and centered on the scribe line as shown in figure 2. The tape is intended to keep the two halves of the test panel from separating after the glass has been broken.

Following the manufacturer's instructions, apply five strips of metallic foil on 5 cm (2 in) centers perpendicular to the scribe line and on the same side of the glass test panel. Apply metallic foil to the remaining test panels in the same manner. Before proceeding with the test, store the test panels in the laboratory for the period of drying time recommended by the manufacturer. In the absence of a manufacturer-specified drying time, dry it for at least 5 days.

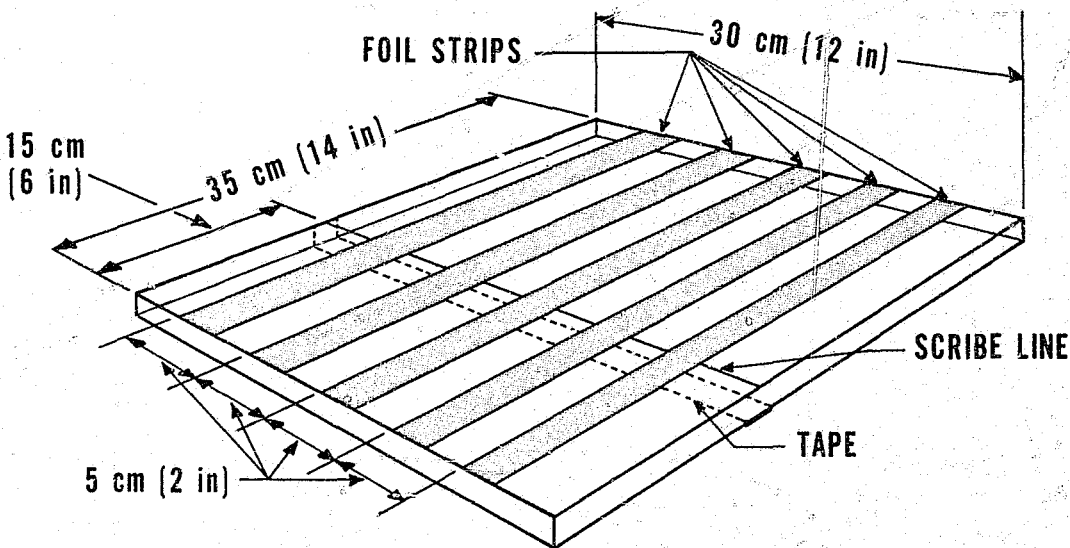

FIGURE 2. Position of tape and foil strips on glass panel.

4. BREAKING PROCEDURE

Breaking plate glass can be dangerous; proper eye and hand protection should always be worn during the breaking operation. Place one of the prepared test panels on the top platform of the break fixture, foil side up, with the 15 cm (6 in) side of the test panel extending out from the break edge, as shown in figure 3. Position the test panel so that the scribe line is directly above and aligned with the break edge. Hold the supported portion of the glass panel firmly against the top platform with one hand, placed at area A of figure 4, and press firmly and quickly on the other end of the glass panel with the other hand, placed at area B of figure 4. This action should result in a clean break along the scribe line. Remove your hands from the test panel carefully so that the two halves of the glass panel do not move.

Check that the two halves are in the proper position; i.e., with no hand pressure on the glass panel. The fully supported half should rest flat on the upper platform and the other half should be supported by the tape at the break edge of the fixture and along the opposite edge by the lower platform of the fixture.

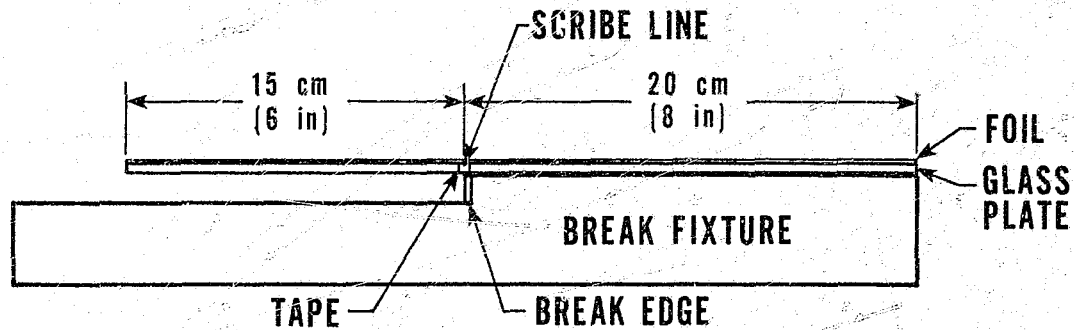

FIGURE 3. Position of glass plate on break fixture.

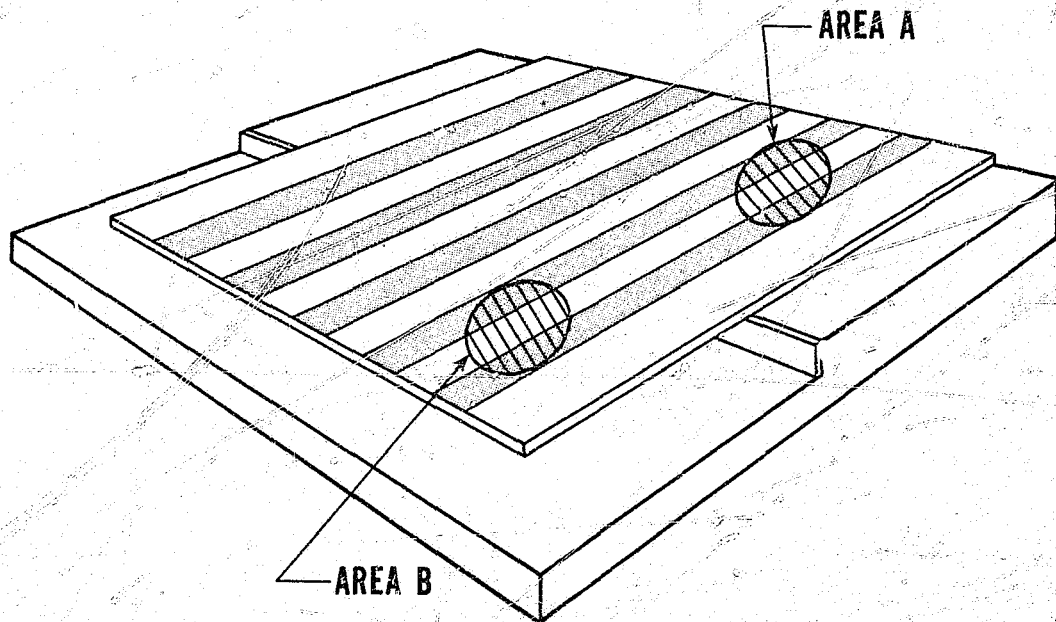

FIGURE 4. Position of hands during breaking of glass.

5. EVALUATION PROCEDURE

Examine the glass test panel to be sure there is a good clean break across at least a portion of the panel. There should be only a single break line and it should follow the scribe line. Only those foil strips which cross a good clean break should be tested electrically. Thus, fewer than five foil strips may be evaluated for each test panel that is broken.

Use an ohmmeter meeting the requirements of paragraph 2.4 to test the electrical continuity of each foil strip across the break. Each foil strip that has a resistance greater than 100 k Ω should be considered broken.

Continue to evaluate individual foil strips until at least 20 have been tested. Evaluate the electrical resistance of all foil strips that cross a good clean break. If all of the foil strips on each glass test panel cross a clean break, a total of four glass test panels should be broken and the resistance of each strip measured. If some strips do not cross a clean break, break additional panels until the electrical resistance of 20 strips has been measured.

The foil is considered to be suitable for use in alarm systems if a minimum of 17 of the 20 strips are found to be broken; i.e., have a resistance greater than 100 k Ω .

**ANNOUNCEMENT OF NEW PUBLICATIONS ON
NATIONAL CRIME AND RELATED SUBJECTS**

Superintendent of Documents,
Government Printing Office,
Washington, D.C. 20402

Dear Sir:

Please add my name to the announcement list of new publications to be issued
on the above subjects (including this NBS series):

Name _____

Company _____

Address _____

City _____ State _____ Zip Code _____

(Notification Key N-538)