

Evaluation of the Judicial Oversight Demonstration Initiative: Baseline and Implementation Report

Christine DeStefano
Adele Harrell
Lisa Newmark
Christy Visher

This research was sponsored by the National Institute of Justice under Cooperative Agreement 99-WT-VX-K005. The opinions and conclusions expressed in this document are solely those of the authors and do not necessarily reflect the views of the U.S. Department of Justice, The Urban Institute, its trustees, or its funders.



Table of Contents

Acknowledgements	4
Introduction	1
Overview of the Judicial Oversight Demonstration Model.....	3
Dorchester, MA	5
Partner Agency Profiles Prior to Implementation of JOD.....	5
JOD Project Planning and Management	11
Planned Agency Changes and Initial Implementation	16
JOD Implementation Timeline.....	28
Milwaukee, WI.....	29
Partner Agency Profiles Prior to Implementation of JOD.....	29
Milwaukee JOD Initiative.....	36
Planned Agency Changes and Initial Implementation	40
JOD Implementation Timeline.....	49
Washtenaw County, MI	50
Partner Agency Profiles Prior to Implementation of JOD.....	50
Washtenaw County JOD Initiative	60
Planned Agency Changes and Initial Implementation	65
JOD Implementation Timeline.....	72
Appendix A. Pre-Trial Monitoring Project (Milwaukee, WI)	
Appendix B. Domestic Violence Order of Conditional Release (Washtenaw County, MI)	
Appendix C. Prosecuting Attorney: Eligibility Requirements for Deferral in Domestic Violence (Washtenaw County, MI)	
Appendix D. Proposed Protocol for Weapons Seizure and Storage in Domestic Violence Cases (Washtenaw County, MI)	
Appendix E. Staff Involved in Judicial Oversight Demonstration	

Acknowledgements

The authors would like to thank members of the Judicial Oversight Demonstration (JOD) project staff for their time and effort in reviewing earlier drafts of this report. Staff in each site include:

- **Dorchester, MA:** Deirdre Kennedy (Project Director) and Marjorie Bernadeau Alexandre (Site Evaluation Coordinator)
- **Milwaukee, MI:** Carmen Pitre (Project Director) and Terri Strodthoff (Site Evaluation Coordinator – through August 2001)
- **Washtenaw County, WI:** Alan Israel (Project Director) and Marguerite Grabarek (Site Evaluation Coordinator)

Introduction

Domestic violence is a complex issue for communities across the country. When the criminal justice system intervenes in domestic violence cases, numerous agencies and departments become involved. In addition to civil, criminal, and family courts, agencies such as probation, batterer intervention programs, child protective services, law enforcement, victim advocacy organizations, district attorney's offices, and other legal and social support associations are also involved.

Success in reducing repeat offenses and ensuring victim safety in domestic violence cases depends largely on effective collaboration between these agencies, individuals seeking assistance from the system and the community at large. When there is a lack of collaboration, victims face an increased risk of repeated violence. Practitioners agree that the most effective way to reduce domestic violence is a consistent and coordinated response from the community, along with clear and immediate consequences from the judicial system for those who batter.

The Judicial Oversight Demonstration (JOD) Initiative tests the idea that a coordinated community response to domestic violence, a focused judicial response, and a systematic criminal justice response can improve victim safety and service provision, as well as increase offender accountability.

The priorities of the JOD initiative include victim safety and well-being, strong judicial commitment to positively affecting victim safety and offender accountability as well as improvement of the availability of victim services and advocacy in coordination with all segments of the criminal justice system and the community.

To hold offenders accountable, the JOD initiative encourages the development or enhancement of grassroots community and justice system partnerships designed to assist offenders in changing abusive behavior.

Each demonstration site is working to implement a strong, data-driven research component to measure impact – that is, “what works” – to reduce or stop domestic violence, enhance victim safety and well-being, and hold batterers accountable.

During fiscal year 1999, three demonstration sites were competitively selected to participate in this five-year oversight demonstration initiative: City of Boston/Dorchester District Court, MA; Washtenaw County, Ann Arbor, MI; and Milwaukee County, WI. Since implementation, each demonstration site has developed multiple governmental and non-governmental partnerships working to address domestic violence. Typical partnerships include victim advocacy organizations, local law enforcement agencies, prosecution offices, courts, probation and parole offices, representatives from the private and public defense bar, batterer intervention services, and other governmental and non-governmental social service providers – all working to create long-term sustainability of positive local innovations.

In addition, each site employs a local project director and a local site evaluator who serve as the project's primary points of contact and oversee the initiative's implementation.

The JOD initiative is jointly funded and managed by the U.S. Department of Justice, Office of Justice Programs' Violence Against Women Office and the National Institute of Justice. In addition to the

programmatic initiatives at each site, there are two additional components: a comprehensive national evaluation and a centralized technical assistance effort. The national evaluation is being conducted by the Urban Institute (UI) in Washington, DC. The Urban Institute's work is informed by the National Institute of Justice's National Evaluation Program Board and UI's close collaboration with each site's local evaluator – all working to identify and disseminate knowledge and skills acquired by local efforts.

The technical assistance is led by the Vera Institute of Justice in New York, NY. To provide this assistance, Vera and the Violence Against Women Office have assembled a team of national associates – active practitioners and experts grounded in practice – who work in consultation with the sites to help them navigate the political, financial, and bureaucratic obstacles that frequently block system change. Associates provide on-site consultations, training, and educational opportunities within and across sites, as well as providing direction to the national partners.

The first phase of the Urban Institute's evaluation of JOD is focused on two primary objectives:

1. A formative and process evaluation to document the development of JOD policies and procedures, provide feedback on implementation issues, work with sites to develop a set of performance indicators; and
2. Designing an impact evaluation to test the central hypothesis: Strong judicial oversight of domestic violence offenders, together with extensive graduated sanctions for offenders and comprehensive services for victims, will reduce re-offending, increase accountability of the defendant and the system, and enhance victim safety.

This report from the process evaluation describes the network of agencies participating in JOD at each site, their policies, services, and collaborative efforts related to domestic violence prior to JOD, their plans for JOD, and progress towards implementation since receiving their award from the Violence Against Women Office. By summarizing the history and resources available at the start of the project, we hope to build the basis for understanding system change in light of the strengths and challenges with which these carefully selected sites approached JOD.

Overview of the Judicial Oversight Demonstration Model

The Judicial Oversight Demonstration (JOD) Initiative tests the idea that a coordinated community response, a focused judicial response, and a systemic criminal justice response can improve victim safety and service provision, as well as offender accountability. The priorities of the JOD initiative include:

- Victim safety and well-being.
- A strong judicial commitment to positively affecting victim safety and offender accountability.
- Improvement in the availability of victim services and advocacy in coordination with all segments of the criminal justice system and the community.
- Development or enhancement of grassroots community and justice system partnerships designed to assist offenders in changing abusive behavior.

Each demonstration site is working to implement a strong, data-driven research component to measure impact – that is, “what works” – to reduce or stop domestic violence, enhance victim safety and well-being, and hold batterers accountable.

The Judicial Oversight Demonstration “model” includes the following critical elements:

- *Uniform and consistent initial responses to domestic violence offenses*, including: a) pro-arrest policies, b) arrest of primary aggressor, and c) a coordinated response by law enforcement and victim’s advocates.
- *Coordinated victim advocacy and services*, including: a) contact by victim’s advocates as soon as possible after the domestic violence call, b) an individualized “safety plan” for the victim and children (if appropriate), and c) provision of needed services such as shelters, protection orders, etc.
- *Strong offender accountability and oversight*, including: a) intensive court-based supervision, b) referral to appropriate batterer intervention programs, and c) administrative and judicial sanctions and incentives to influence offender behavior.
- Rigorous research and evaluation component to gauge the initiative’s effects on victims, offenders, the criminal justice system, and the community.
- Centralized technical assistance to aid sites in planning, implementation and problem solving.

The central role of the court in this process is illustrated in Figure 1.

Figure 1.
JOD Network of Partners

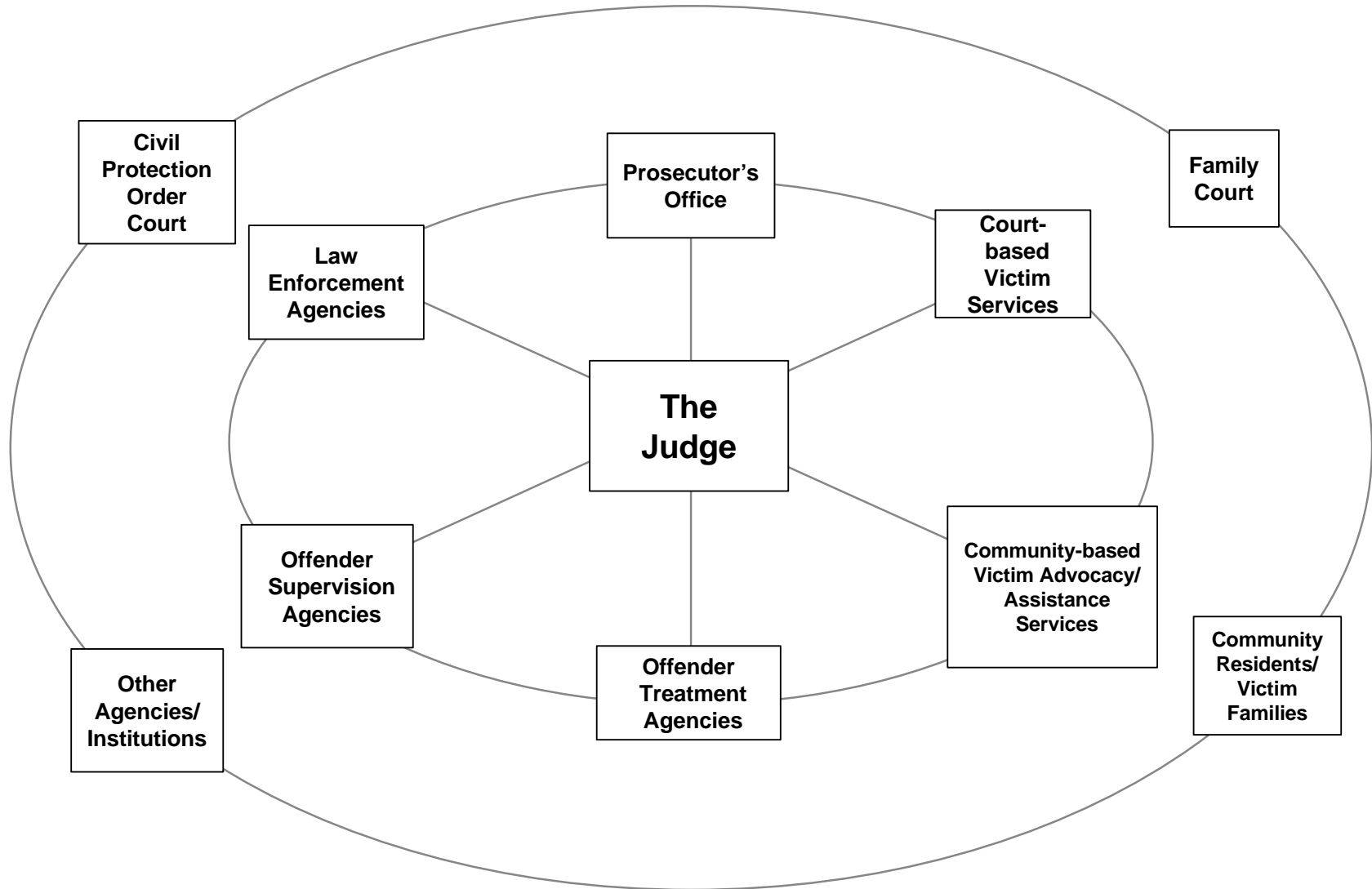

Dorchester, MA

The Dorchester District Court serves Dorchester and Mattapan, MA, which are in Suffolk County and are neighborhoods of Boston. Since the court is the Dorchester District Court, we will refer to the community as Dorchester, with the understanding that Mattapan is included as well. Dorchester is on the whole a lower-income area with an extremely diverse population. According to 2000 Census data, Dorchester has a population of about 130,000, which is about 20 percent of the population of Boston. Most residents are members of minority groups (48 percent are African-American, 12 percent are Latino, and 8 percent are Asian), and about one-quarter of the residents immigrated from various parts of the world, primarily the Caribbean, Africa, Latin America, and Southeast Asia.

Key actors in the Dorchester community have recognized the importance and difficulty of domestic violence cases, and have taken steps to meet the challenge. In 1991, a Dorchester Court judge initiated the Dorchester Court Roundtable. The Roundtable obtained a Coordinated Community Response grant from the Centers for Disease Control and Prevention in 1996, and grew into the Dorchester Community Roundtable. This is a coordinated community response project that placed victims' advocates in community health centers to provide crisis intervention, referrals, counseling, safety planning, support groups, and criminal justice system advocacy. Membership includes representatives of many different segments of the community, including victim advocates, judges, police, prosecutors, probation officers, health care providers, mental health and substance abuse service providers, and batterer intervention programs. The judge who initiated the Roundtable also chairs the Massachusetts District Court Professional Development Group for Abuse Prevention Proceedings, which developed the Trial Courts' Guidelines for Judicial Practice in Abuse Prevention Proceedings, and another Dorchester judge serves on that group. The JOD project builds on the foundation laid by these earlier efforts.

Partner Agency Profiles Prior to Implementation of JOD

The agencies involved in the JOD initiative include the Dorchester District Court; the Suffolk County District Attorney's Office; the U.S. Attorney's Office; the Boston Police Department; the Department of Probation; several batterer intervention programs, of which only one is a funded partner; representatives of the defense bar; and several victim service providers, including advocates based in law enforcement and prosecution agencies. This section summarizes how each agency operated prior to the implementation of JOD, now being phased in.

Dorchester District Court

The Dorchester District Court is a state agency within the Trial Court of Massachusetts. Prior to the implementation of the specialized JOD court in September 2000, five judges handled domestic violence and all other types of cases in five separate sessions. Sometimes visiting judges from other districts handled these cases as well. While there was no specialized docket for domestic violence cases, most judges attempted to hear the civil restraining orders as soon as they were advanced into the sessions throughout the day, so that plaintiffs did not have to spend a lot of time waiting in the courthouse.

Since there were no specialized procedures for domestic violence cases there was no need to identify these cases in court records, hence baseline data are severely limited for the court. In fiscal year 2000, 1,787 Abuse Prevention orders (referred to as 209A for the state statute) were filed, and 1,449 were disposed in the Dorchester court. In fiscal year 2000, 8,537 criminal complaints were filed in the court and 8,953 complaints were disposed, but data are not available to assess how many of these were for domestic violence matters.

Relationships with Other Agencies

Several Dorchester judges have been active in efforts to advance the court's and the community's response to domestic violence cases. One judge was instrumental in founding the Dorchester Community Roundtable Project, which has served as a coordination vehicle for the last five years. Through the Roundtable, court personnel have been working closely with personnel from other justice system agencies, and community providers such as victim advocates; health, mental health, and substance abuse caregivers; and batterer intervention programs.

Suffolk County District Attorney's Office

The District Attorney's Office had domestic violence specialists before JOD implementation, with two attorneys carrying caseloads of about 200 open cases (not all of which were domestic violence). The District Attorney's Office also had three victim/witness advocates housed in the courthouse, who met with victims whose offender had been arrested. The advocates' services included providing information about the court process, updates on case activities, assistance with victim impact statements and victims' compensation claims, crisis assessment, safety planning, and referrals to community-based services.

The District Attorney's Office did not use vertical prosecution and did not have sufficient resources for case investigation and preparation to consistently use evidence-based prosecution policies. This Office is now developing an automated case management system, so caseload data from the pre-JOD period are not readily available.

Relationships with Other Agencies

Members of the District Attorney's Office have participated in the Dorchester Roundtable project. The District Attorney's Office had a victim/witness advocate funded through the Roundtable. Prosecutors have worked most closely with police (on evidence collection) and probation officers (on offender supervision). However, room for improvement remained in the sharing of information and technical expertise. For example, police incident reports did not always reach prosecutors in a timely manner, and there were no clear procedures for prosecutors to assist probation officers in conducting probation surrender hearings.

U.S. Attorney's Office

The U.S. Attorney's Office has a domestic violence section that aggressively pursues domestic violence violations subject to federal prosecution (often working with the Suffolk County District Attorney's Office to determine case referrals, prepare cases, and so on). The head of the domestic violence section was instrumental in planning the JOD initiatives, bringing the partners together, writing the grant proposal, and keeping the project moving forward during its early period before the funding was accessible.

Relationships with Other Agencies

The U.S. Attorney's Office has worked with the Suffolk County District Attorney's Office on a case-by-case level. The U.S. Attorney's Office also had other connections in the Dorchester Court prior to JOD, enabling it to take a leadership role, along with Dorchester court and police personnel, in writing the JOD proposal and bringing the partner agencies together.

Boston Police Department

The Boston Police Department has had a central domestic violence unit that develops policies and information on domestic violence case activity. At the case level, the Dorchester District Court jurisdiction is served by three precincts of the City of Boston Police Department: B-2, B-3, and C-11 (B-2 and B-3 also serve other district courts, so there is not perfect congruence between the police precincts and the court jurisdictional area). These precincts reported a total of 960 incidents of domestic violence during 2000, approximately one-quarter of all violent crimes.

Each of the precincts has had at least one domestic violence detective (although the position(s) was not always filled) and one peace liaison (victim advocate) predating the JOD initiative. The role of the peace liaison is to make contact with the victim, explain police procedures, assist victims in working with police officers and prosecutors, and refer victims to community services.

Relationships with Other Agencies

Police personnel participated in the Dorchester Roundtable prior to the JOD project, and were a key party in writing the JOD proposal and bringing the partner agencies together. On a case level, police staff worked most closely with prosecutors, as described previously. A police officer is stationed in the courthouse to serve as a liaison between the Boston Police Department and the Dorchester District Court. The police department has a central Domestic Violence Unit that serves a crucial role in compiling information on domestic violence cases and coordinating with community agencies and city-wide agencies such as the Mayor's Women's Commission.

Probation Office

The Probation Office is a court agency, and is administered by the state's Office of the Commissioner of Probation. Prior to JOD, the Probation Office had a specialized domestic violence unit headed by an assistant chief probation officer and staffed by four probation officers, but caseloads were very high, at about 160 cases per officer. Some contacts with victims and with other agencies involved in the case (such as batterer intervention programs) were made, but caseloads prohibited very concentrated supervision for all but the most risky cases. Probation officers typically contacted probationers every week to two weeks, but had little contact with victims. Collateral contacts (with other agencies working with the probationer, such as batterer intervention programs or substance abuse treatment providers) were monthly at best in the pre-JOD period.

In addition, officers took primary responsibility for requesting and conducting surrender hearings (in response to alleged violations of probation), with occasional assistance from the District Attorney's Office, on request from Probation (this only happened sporadically, since there was no organized procedure for requesting and receiving such assistance). During 2000, there were a total of 3,608 probation surrenders in Dorchester, of which 2,432 (65 percent) were for technical violations and 1,290 (35 percent) were for new criminal charges. This includes all cases; statistics on domestic violence cases only are not available.

Most domestic violence probationers were mandated to attend batterer intervention programs (and sometimes substance abuse programs as well) before initiation of JOD. Probation officers provided intervention programs with arrest reports and criminal records, after obtaining appropriate releases from offenders ordered to these programs.

Relationships with Other Agencies

Probation personnel have participated in the Dorchester Roundtable. Probation is an arm of the court system; officers are housed in the courthouse and probation and court management and administrative functions are, to some extent, integrated. On a case level, probation officers are responsible for bringing violation allegations to the court's attention and conducting surrender hearings (with occasional assistance from prosecution, as described previously). Probation officers also work closely with batterer intervention programs, by providing them with information on referrals and receiving information on program participation by probationers. There was limited coordination with domestic violence detectives for home visits, and with victim services and other community agencies, due to the high caseload probation officers carried.

Batterer Intervention Programs

Batterer intervention is provided to Dorchester District Court cases by four primary non-profit organizations: Common Purpose, Roxbury Comprehensive Multi-Service Center, Emerge, and Spectrum Health Service, Inc.'s Prevention of Abuse and Violence through Education program. Batterer intervention programs in Massachusetts are subject to very detailed state program standards. Before JOD, the programs were able to provide services in a few languages other than English (Spanish, Vietnamese, Chinese, and Cambodian-Khmer), but serving the wide range of diversity represented in the Dorchester population has been a challenge (other commonly spoken languages include Cape Verdean Portuguese and Haitian Creole).

The programs do not keep records on recidivism, but approximately 25 percent of participants were terminated from batterer intervention programs for failure to meet program requirements.

Relationships with Other Agencies

These programs have a four-year history of working closely with probation and victim advocates, as part of the Dorchester Community Roundtable Batterer Intervention Subcommittee. The programs provided monthly reports on each client to his or her probation officer, including information on attendance and compliance with program requirements, threats, indicators of dangerousness, and indicators of substance abuse. These programs have also worked with victim advocates to refer their clients' partners to services for domestic violence victims.

Defense Bar

The defense bar has not participated in any organized manner in the processing of domestic violence cases since these cases were not separated out prior to JOD. Cases have been assigned primarily to public defenders employed by Suffolk Lawyers for Justice, who have rotating duty days at the court. There has been no specialized training for the defense bar and no effort has been made to include them in specialized domestic violence training programs offered by victim advocacy agencies. However, staff from the Committee for Public Counsel Services did participate on the JOD grant planning committee.

Victim Service Providers

Victims are served by a wide variety of providers, including both public-based (peace liaisons in the police department and victim/witness advocates in the District Attorney's Office) and several private non-profit organizations (Dorchester Community Roundtable, Casa Myrna Vasquez, Northeastern University Law Clinic, and several other organizations based in hospitals or other community agencies). The only advocates housed at the courthouse, prior to JOD, were prosecutor-based advocates and Northeastern students.

Police- and prosecutor-based advocates serve victims with criminal cases. In addition to services to fulfill state victims' rights laws (primarily around information on and participation in the justice system), these advocates also offer crisis assessment, safety planning, and service referrals. Most of the non-profit organizations serve whatever victims come to them for services (they may have civil cases, criminal cases, both types of cases, or no cases at all), and offer a broad range of services for criminal justice system-related and other needs. Advocates from Northeastern assist primarily with civil restraining orders.

Relationships with Other Agencies

Prior to JOD there was not a great deal of cohesiveness among public-based and non-profit victim service agencies, although efforts to increase collaboration have been a focus of the Dorchester Roundtable project. Advocates have worked with other agencies on a case level at various stages of case processing (e.g., with police around the time of the incident and arrest, and with prosecutors as the case progresses through the court).

JOD Project Planning and Management

Dorchester's approach to the planning and management of the Judicial Oversight Demonstration initiative involves several layers of organizational structures and processes. An Executive Committee was formed very early in the project to provide overall vision and direction. This Committee is chaired by the First Justice of the Dorchester District Court, and is composed of representatives from all major partner agencies. It meets every other Wednesday morning, and meetings are facilitated by the Project Director.

The Executive Committee formed a number of subcommittees to focus on planning and troubleshooting in specific areas. These Subcommittees have met as needed (some approximately monthly and others for a short planning period), and most have produced reports to the Executive Committee containing products and recommendations. The Subcommittees include:

- Subcommittee on Police Procedures
- Subcommittee on Interface Between Police and Prosecutors
- Subcommittee on Prosecution
- Subcommittee on Victim Advocacy
- Subcommittee on Briefing Sessions for Defendants in Restraining Order Actions
- Subcommittee on Intervention Programs for Non-Criminal Cases
- Subcommittee on Education Program for Defense Bar
- Subcommittee on Re-Integration of Offenders into Community
- Subcommittee on Hiring (JOD Project Director and Site Evaluation Coordinator positions)

Dorchester's vision of the Judicial Oversight Demonstration project involves enhancements in a number of agencies that work with domestic violence cases. To summarize:

- Create a specialized domestic violence court session to manage all civil restraining orders and misdemeanor and lower-level felony criminal cases, including post-disposition reviews of probationers.
- Enhance the District Attorney's Office by expanding the domestic violence unit, implementing vertical prosecution, and facilitating evidence-based prosecution through improved case preparation and staff training.
- Train police officers in advanced case investigation, improve procedures for identifying high-risk cases, improve information sharing by developing new reporting systems, and use overtime for case preparation.
- Enhance the probation office's domestic violence unit by doubling staff, reducing caseloads, and providing intensive supervision to all domestic violence probationers. In conjunction with the defense bar, batterer intervention programs, and victim services, develop and implement an educational program for restraining order respondents.
- Expand the availability of batterer intervention services to indigent and Haitian Creole speaking offenders. Provide training to other JOD partners and work more closely with probation officers and victims.
- Improve coordination among public-based and non-profit victim service providers. Expand services to victims from police-based advocates through an on-call project, if the pilot experience in one police precinct is successful. Provide more services from District Attorney-based victim/witness advocates to victims in criminal cases, and more services to restraining order

plaintiffs from a number of non-profit organizations. Services should also be available in additional languages to meet the needs of Dorchester's extremely diverse population.

JOD Management

The Dorchester Judicial Oversight Demonstration grant is managed by the Boston Police Department, with the exception of the funds for Probation (an agency of the state's trial court system), which is administered by the Massachusetts Trial Court Administrative Office, which was awarded these funds through the state's Executive Office for Public Safety. Start-up activities were slowed by delays in making the funds from the Violence Against Women Office available. The award was made entirely to the police department initially, but the police cannot administer funds for the probation department, which is a state agency. The Probation funds were therefore returned to the Violence Against Women Office and re-awarded to the Executive Office for Public Safety, which then re-awarded the funds to the Massachusetts Trial Court. Partner agency personnel showed extraordinary dedication in keeping the project moving forward during the time when funding was not available and key staff were not yet on board (until October 2000).

An attorney with the U.S. Attorney's Office served as the interim Project Director from April 2000 to October 2000. At that time the permanent Project Director was hired, along with the Site Evaluation Coordinator. The Project Director has since taken responsibility for overall management of financial and programmatic functions. The Site Evaluation Coordinator has worked with the Urban Institute and local partners on national evaluation tasks, such as development of the Monthly Reporting Form, site visits, and special sessions to address partner agencies' concerns about research participation. She has also provided data to local partners in response to their requests. The development of an integrated, cross-agency Management Information System was discussed but has been tabled as it met with resistance from several partner agencies. Alternative approaches are being discussed by an MIS Subcommittee, with a focus on linking current databases being used by the police, the trial court (including probation), and the District Attorney's Office.

Representatives from the many partner agencies have participated in a variety of training activities, both local and national. An initial strategic management planning retreat was held in April 2000, with a follow-up session in June 2001. Training in cultural competency issues was also held in June 2001. The court held a half-day in-service training for all court staff, to ensure that they were knowledgeable about JOD, in May 2001. The victim services component had several facilitated meetings prior to the court session's opening to assist in determining the role each agency would have in the project and how victims would be directed through the system. In addition, direct service and supervisory staff from most of the partner agencies participated in a 24-hour training in April 2001 on how to work effectively with men who are abusive.

Appropriate personnel participated in national training opportunities provided by the Vera Institute, including the kick-off conference in February 2000; the Technical Assistance Associates' conference in April 2000; the Batterer Intervention Institutes in May 2000 and August 2000; and the Judicial Institute in February/March 2001. The Project Director participated in Project Directors' meetings in October 2000 and January 2001. The Project Director, Site Evaluation Coordinator, and others as appropriate also participated in evaluation meetings in July 2000 and January 2001, and they participate in the ongoing national partners' conference calls, held approximately monthly to once every two to three months. Most recently (June 2001), the National Institute for Trial Advocacy and the JOD Technical Assistance provider, the Vera Institute of Justice, conducted a three-day skills training for domestic violence unit prosecutors in Dorchester.

The Project Director and several probation officers visited Westchester County's Probation Department in May 2001 to learn more about their victim-focused supervision model. Several partners, such as the judges, victim services, and probation staff, have expressed an interest in additional peer learning opportunities, such as site visits to other JOD sites or other promising practices sites. JOD would also like to explore the option of having a safety audit performed as a check on system functioning.

Figure 2 depicts Dorchester's case flow and their planned enhancements for their JOD initiative. Figure 3 illustrates the partner agencies involved in Dorchester's initiative.

Figure 2.
Dorchester Processing of Criminal Domestic Violence Cases: Planned JOD Enhancements

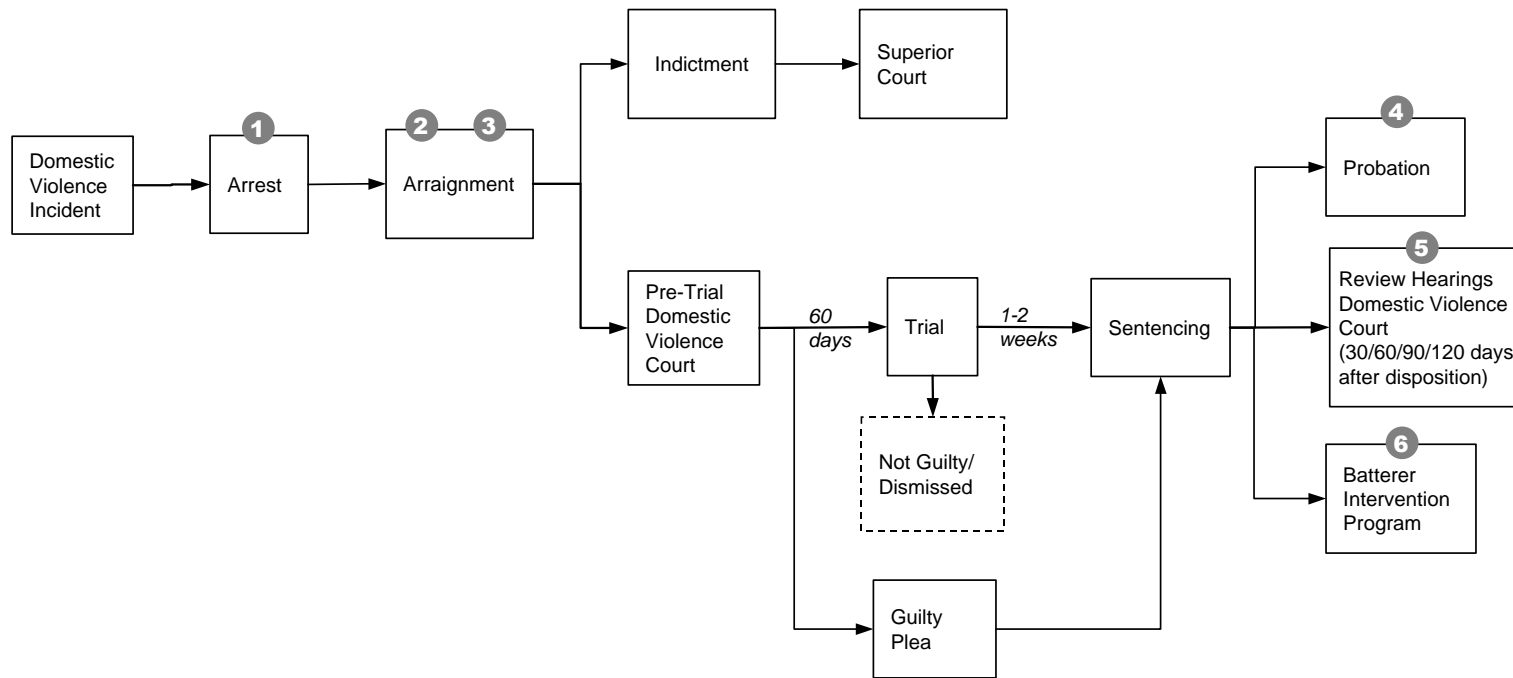

Primary JOD Enhancements

- 1 Boston Police Department’s Area B3 Peace Liaison beeped on arrest cases, to allow immediate contact with victim. (Pilot Project)
- 2 Roundtable triage-advocate housed outside Clerk’s Office makes contact with all victims who come to court house for a restraining order. She assesses immediate needs and refers to other advocates as appropriate. Other victim services are provided throughout case processing by various providers.
- 3 District Attorney’s Office uses vertical, evidence-based prosecution.
- 4 More intense supervision of probationers.
- 5 Review hearings conducted by same judge who adjudicated the case prior to disposition.
- 6 Batterer intervention programs offered in Haitian Creole, to indigent batterers and with more local slots. Batterer intervention programs were already available in English, Spanish, Vietnamese, Chinese, and Cambodian-Khmer.

Figure 3.
Dorchester: JOD Network of Partners

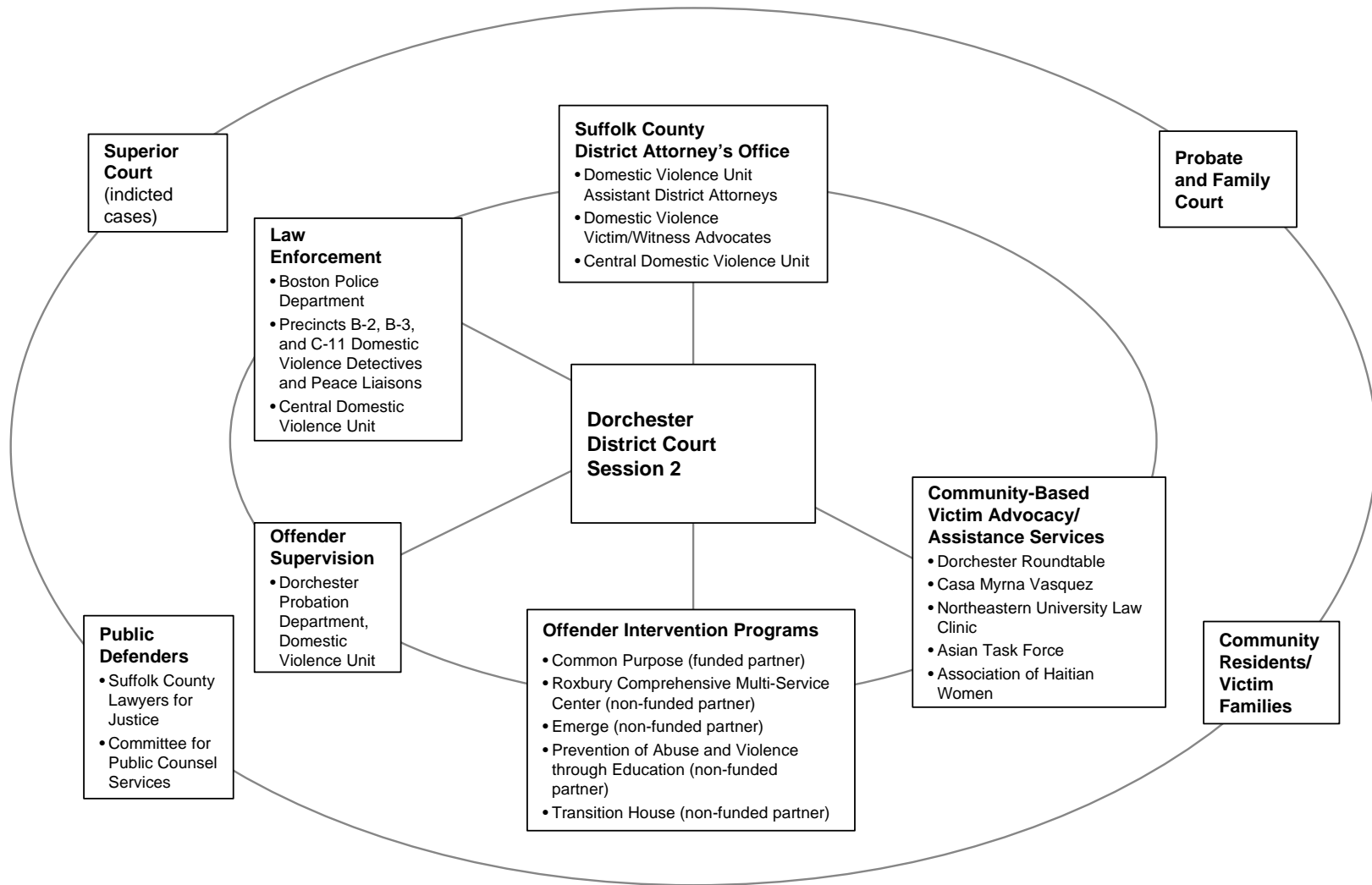

Planned Agency Changes and Initial Implementation

For each of the JOD partner agencies, the planned changes for JOD and the implementation progress since the grant was awarded is discussed. An implementation timeline is presented at the end of this chapter.

Dorchester District Court

Create a special domestic violence session to manage all civil restraining orders and criminal case arraignments, bail hearings, pretrial hearings, disposition by plea of misdemeanor and lower-level felonies (those subject to up to 2½ years in prison), probation reviews, and probation surrender hearings.

The specialized domestic violence court (referred to as Session 2) began hearing cases on September 11, 2000. Probation reviews (approximately 30, 60, and 120 days after sentencing, depending on compliance) were instituted in March 2001. Reviews are heard by the same judge that handled the case in the pre-disposition period, whenever possible. As before JOD, surrender hearings (for alleged probation violations) are heard before whichever judge is available on the earliest possible court date, because a swift response is prioritized. Jury trials are presided over by judges from other sessions.

Two highly trained and committed judges are dedicated to this docket; one takes the bench on Mondays, Tuesdays, and Thursdays, and the other is on the bench on Wednesdays and Fridays. The court handles all restraining orders regardless of familial relationships, but only intimate partner violence criminal cases. Procedures were developed for the clerk magistrate's office to identify appropriate cases and forward them to the specialized court.

The judges manage the cases according to the Massachusetts Court Guidelines for Abuse Prevention Proceedings. They also provide leadership in project management (by chairing the JOD Advisory Board) and training of judicial and other staff on the specialized court, and on model approaches for adjudicating these cases.

An additional resource offered by the Dorchester District Court is an on-site childcare center, staffed by a professional childcare contractor with training from the Child Witness to Violence Program at Boston Medical Center. There is also a 10-hour position funded by the Dorchester Community Roundtable for a Child Witness to Violence staff person stationed at the courthouse to work with the staff of the different agencies at the courthouse around child witness issues.

Court personnel have reported that plea agreements have increased since the specialized court was implemented, and that pleas are more likely to include treatment requirements such as batterers' intervention programs.

A current operational issue is the need for enhanced translation and interpretation services to better fit the needs of this diverse community. Nearly one-quarter of Dorchester residents are immigrants, and the most commonly-spoken languages, besides English, are Spanish, Vietnamese, Haitian Creole, and Cape Verdean Creole. Massachusetts Trial Court Interpreter Services has been contacted about addressing this need, and enhanced services are expected to be in place by September 2001.

Another issue which still confronts the court is increasing the efficiency of its operations. It can be difficult to schedule cases when all attorneys and probation officers (for review or surrender hearings) can be available. At present, cases are often called but not all parties are available to the session, so it has to be re-called later that day or, occasionally, continued to another date. Continuances lead to aging cases that may have difficulty meeting due process requirements. Less-than-optimal operational efficiency is particularly troublesome in a high-volume court like this one. This issue was identified at the June 2001 strategic management planning session and will be addressed in future efforts.

An unexpected consequence of the specialized docket has emerged in which plaintiffs seeking restraining orders may now sometimes wait much longer than they did before the specialized court was begun. At that time, judges would hear these cases as soon as possible after the paperwork was processed and they were sent into five different sessions, since they were considered high priority among the general mix of cases. Now that all restraining orders are sent to only one session, and in addition all the session's cases involve domestic violence, it can be difficult to prioritize the civil restraining order cases for immediate attention. As a result, plaintiffs may sometimes wait much longer than they did before the JOD court began.

This court has a very large caseload and staff are under a great deal of pressure to move cases along.

This leads to burnout and limited opportunities for collateral activities. The possibility of bringing on an additional judge to relieve these pressures is being explored. The court is sensitive to race and gender issues in current staffing, in that both judges are white women and many of the defendants in their cases are minority men, and are attempting to address any perceived imbalances through the process of selecting an additional judge.

Primary JOD staff include:

- Two Judges
- Two Assistant Probation Officers assigned to the courtroom

Suffolk County District Attorney's Office

Expand the specialized domestic violence unit and implement vertical prosecution. Facilitate use of evidence-based prosecution by enhancing case investigation and preparation. Provide specialized training for prosecutors.

The Domestic Violence Unit is now staffed by five assistant district attorneys (including three new hires in August/September 2000) carrying caseloads of about 60–90 open cases, an investigator, and two Domestic Violence Victim Advocates (one funded by JOD and one funded by the Dorchester Community Roundtable project). Cases are prosecuted vertically, which lets prosecutors get to know their cases better and facilitates the use of evidence-based prosecution.

Virtually all cases brought by the police are brought before the court, as the District Attorney's Office does not screen cases for prosecution.¹ No mandatory no-drop policy exists, but prosecutors make every effort to implement evidence-based prosecution. To support this effort, the District Attorney's investigator works with the police to enhance evidence collection. The District Attorney's Office has also obtained more resources for expert testimony and for equipment such as tape recorders and cameras, to enhance evidence collection. There is an evening on-call assistant district attorney in one of the Dorchester police precincts funded through another grant, and plans are being developed to expand this function to additional JOD cases.

Training of new assistant district attorneys has been identified as a need, since many of them have little experience with these cases. The assistant district attorneys attended a state-wide conference in May 2001 and a three-day session in June 2001 sponsored by Vera and the National Institute for Trial Advocacy.

Primary JOD staff include:

- Chief of Central Domestic Violence Unit
- Deputy Chief of Central Domestic Violence Unit
- Supervisor of Dorchester Domestic Violence Assistant District Attorneys
- Four Assistant District Attorneys
- Investigator
- Deputy Chief of Victim/Witness Program
- Two Domestic Violence Victim Advocates

¹ Under state law (chapter 218 section 35) the police request an application for complaint from the clerk's office (to bring court charges from an arrest). The clerk considers the police report and other information provided by the police. Upon issuing a complaint, the clerk determines the initial charges and refers the case to prosecutors for arraignment. The prosecutor can then change the charges, but the prosecutor is not involved in the initial charging decision.

U.S. Attorney's Office

Coordinate with other agencies on case referrals and community education. Continue to participate in project planning, management, and training activities.

Points of contact between the U.S. Attorney's Office and the Suffolk County District Attorney's Office have been established. Cases which may be appropriate for federal prosecution are reviewed and referred as appropriate. Representatives from the U.S. Attorney's Office participate in JOD planning and management activities, and in training and community education events.

The Associate U.S. Attorney who served as the interim project director is continuing to serve on the Executive Committee. She is scheduled to assist with trainings for Probation and the District Attorney's Office, and she has researched dangerousness assessment tools and is sharing that knowledge with others (the police, Suffolk County District Attorney's Office, and probation).

Primary JOD staff include:

- Assistant U.S. Attorney
- Law Enforcement Coordinator

Boston Police Department

Train police personnel in advanced case investigation procedures. Use overtime for case preparation. Improve procedures for identifying high-risk cases. Enhance service of restraining orders. Enhance response to firearm possession by arrestees or restraining order respondents. Share incident and criminal history information with partner agencies more quickly. Develop a specialized domestic violence report form to accompany the incident report.

Since JOD implementation began, each of the three police precincts serving the Dorchester District Court has had three domestic violence detective positions, and the positions are currently filled. These positions are spread across day and night shifts, providing better overall coverage than before JOD.

In response to the identification of mutual arrests as a troubling issue, police personnel, including over two dozen Dorchester-area domestic violence detectives and Central Domestic Violence Unit staff, attended dominant aggressor training. The detectives also attended training in photographic evidence. Dorchester-area police personnel have also attended a three-day training on batterer characteristics and methods of intervention. Case preparation overtime has not been used yet but is expected to be used in the future.

Central Domestic Violence Unit staff have developed a database for tracking domestic violence offenses and identifying repeat or high risk offenders. Those with outstanding warrants are flagged and prioritized for arrest. Written information is shared with domestic violence detectives in the precincts so they have more complete information for assessing cases and responding appropriately. This information is also shared with the District Attorney's Office and the Probation Department through phone contacts. Future efforts will focus on more systematic methods of sharing the information across agencies.

Police are now providing incident reports to the District Attorney's Office and Probation at the time of arrest. Probation forwards the reports to batterer intervention programs once the defendants are enrolled. Plans are underway to hire a night-time clerk to compile police reports and criminal history information and distribute it to partner agencies immediately.

Restraining orders now receive same-day service for high-risk cases. Other cases are served by the following day, once the orders are logged at the local police station. Continuing efforts are underway to expedite restraining order service.

Additional efforts to enhance police responses to firearm possession are needed. Currently, the state's firearms registry is checked only in cases in which firearms are a feature of the criminal incident, or the defendant is identified as repeat or high risk in the police database. Additional efforts are also needed to improve the department's policy on domestic violence defendants or restraining order respondents who are police officers. At present these officers are issued their service weapons during their tour of duty, returning the weapons when they go off duty.

A specialized domestic violence report form was developed to accompany the police incident report. This form has a body map and instructions for documenting injuries. The police have distributed this form to patrol officers and roll call training is being scheduled. The police department has also developed a checklist for patrol officers to document evidence collection at crime scenes and do a dangerousness assessment.

An additional initiative which has developed over the course of JOD implementation is the development of more precise categories and definitions for 911 operators to use in classifying calls for service. Pending approval from department management, dispatchers will categorize calls as either intimate partner domestic violence or non-intimate partner domestic violence.

Primary JOD staff include:

- Deputy Superintendent, Bureau of Investigative Services
- Commander of the Domestic Violence Unit
- Senior Policy Analyst, Strategic Planning
- Captains, Detectives, Officers, and Peace Liaisons in Precincts B-2, B-3, and C-11
- JOD Project Director
- JOD Site Evaluation Coordinator

Probation Office

Enhance the Domestic Violence Unit by increasing staff, decreasing caseloads, and providing intensive supervision to all domestic violence offenders. Increase contact with victims and coordination with child protection services. Enhance handling of surrender hearings. Develop and implement an educational program for restraining order respondents, in conjunction with the defense bar, batterer intervention programs, and victim services.

Four new probation officers were hired in November 2000 for Probation's Domestic Violence Unit, which doubled its staffing and cut caseloads in half, to about 80 cases per officer. First-time offenders with cases that did not result in serious injury are typically placed on probation for one to two years, with terms including batterer intervention, substance abuse testing and treatment as appropriate, participation in Probation's Fatherhood program as appropriate, employment, compliance with restraining orders, and no further abuse. Repeat offenders and offenders who caused physical injury are usually given split sentences, with periods of incarceration from 30 days to 18 months followed by a period of probation, with the same terms of probation.

All domestic violence probationers are now placed on intensive supervision. Probation officers are monitoring attendance at programs more closely, verifying employment and residence status, and making more frequent home visits. They are also responding more quickly to technical or criminal violations of probation by advancing cases for review or surrender hearings more quickly. Two assistant probation officers provide court coverage for the domestic violence session.

Probation officers have increased their contact with victims. Protocols for victim contact still need to be developed in conjunction with victim service agencies.

Probation officers have for some years worked very closely with batterer intervention programs. Officers and counselors from batterer intervention programs attend monthly meetings to keep communication open and troubleshoot problems as they arise. The programs submit monthly progress reports to probation officers, and call officers weekly to advise them of any problems that may have arisen on their cases.

The District Attorney's Office has worked with Probation to assist in probation surrender hearings. These cases are conferenced by assistant district attorneys and probation officers to identify who to summons and strategies for evidence presentation. Domestic Violence Unit probation officers attended a training in May 2001 on examining and cross-examining witnesses in probation violation hearings.

Probation is working with child protective services on a case-by-case basis, to ensure child safety and enhance compliance with relevant probation conditions. Probation has recently joined a collaborative effort with the Department of Social Services (which provides child protective services), the Department of Mental Health, the Department of Youth Services (dealing with juvenile offenders), and the Boston Public Schools. This collaboration will enhance and develop standardized mechanisms for communication and coordination among these agencies. Probation is also developing a prevention program for youthful offenders, to address domestic violence, dating violence, and gang violence.

Probation has been working with the defense bar, batterer intervention programs, and victim services to develop an educational program for restraining-order respondents. This program, involving probation personnel and outreach workers from the non-profit Massachusetts Prevention Center, started in early July 2001. The program provides educational sessions for those subject to restraining orders who do not also have criminal cases, to ensure they understand the meaning and terms of restraining orders, consequences for non-compliance, and requirements for altering or vacating orders. In early July 2001, assistant probation officers started doing the probation part of the briefing after an order is issued. Although these restraining-order respondents do not have criminal cases, probation officers are participating in this program by detailing the specifics of the order and stressing that it is a court order, not the victim's order. They also clarify that violation of the order is a criminal offense, and outline the penalties and their impact on housing, employment, and immigration. There has been a delay in the Massachusetts Prevention Center's hiring of outreach workers. It looks as if that part of the briefing will be starting in late August/early September.

Pretrial supervision is rarely used, but when it is ordered by a judge it is provided by the Probation Department. Probation does provide some pretrial services in the form of providing defendants' criminal history and financial information to the court.

Primary JOD staff include:

- Chief Probation Officer
- Assistant Chief Probation Officer
- Eight Probation Officers
- Two Assistant Probation Officers

Batterer Intervention Programs

Work closely with Probation Officers and enhance victim contacts. Provide support services to a new Haitian Creole program. Collaborate on the educational program for restraining order respondents without criminal cases. Provide training to other JOD partners.

The batterer intervention providers (Common Purpose, Roxbury Comprehensive Multi-Service Center, Emerge, and Spectrum Health Systems, Inc.'s Prevention of Abuse and Violence through Education program) have reported increasing caseloads because of increased referrals from courts (in line with court personnel's reports that defendants are more likely to accept plea agreements with program conditions). These agencies have been working to establish closer ties and more frequent communication with probation officers. In addition, victims whose batterers are in a program are contacted at least three times while the offender is in the program. The purposes of these contacts are to enhance the victims' understanding of what the program is and is not about, and to obtain information on the offender's behavior toward the victim.

Transition House, a victim service provider, is providing batterer intervention services in Haitian Creole, with extensive technical support from Common Purpose. This arrangement was reached as an official change in Common Purpose's scope of services under the grant. Independently of the JOD project, the Massachusetts Department of Public Health awarded funds to Transition House for this programming, during the time period between the original JOD proposal submission and the receipt of funds from the Violence Against Women Office. Transition House has a strong Haitian Creole program and JOD wanted to be supportive of this community based effort rather than set up a competitor. So, Common Purpose was asked to provide extensive support to this new program.

A batterer intervention consultant provides input at meetings of the Executive Committee and the Batterer Intervention Subcommittee. He has also worked extensively on collaborative efforts to develop and implement the restraining order respondent educational program (discussed more fully under Probation).

Common Purpose provided three-day training to 38 JOD partner agency staff on batterer characteristics, dangerousness assessment, and techniques for intervention, in April 2001.

A challenge confronting batterer intervention programs arises from the large numbers of women arrested on domestic violence charges (approximately 15 percent of the caseload). Appropriate services for heterosexual women referred to intervention programs need to be developed, as there are no services currently available for this group. Other areas of need include services for recent immigrants who speak languages in which services are not currently provided (for example, Polish and Russian). Emerge offers programs for same sex batterers, both men and women.

Another challenge is the need to involve collateral community resources to address batterers' other challenges, such as substance abuse, educational or employment deficiencies, parenting skills, and so on. Staff in batterer intervention programs have suggested that orders to such programs as a condition of probation may be useful in accessing these services.

Primary JOD staff include:

- Executive Director and Administrative Director, Common Purpose
- Program Director, Co-Director, and Training Director, Emerge
- Program Director, Roxbury Comprehensive Multi-Service Center
- Program Coordinator, Spectrum Health Systems, Inc.'s Prevention of Abuse and Violence through Education program
- Executive Director and Counselor, Transition House
- JOD Project Consultant

Defense Bar

Participate in the JOD initiative by representing the defendants' perspective and developing programs to benefit defendants.

Members of the defense bar have participated in management activities, such as the semi-weekly meetings of the Executive Committee and the Defense Bar Subcommittee. They have also collaborated with Probation, batterer intervention, and victim services in developing the restraining order respondent educational program. It has recently been identified that, while individuals who have been participating in JOD activities are very competent and dedicated, additional members of the defense bar with closer ties to the Dorchester court and community are needed. The Project Director and one of the judges are scheduled to address the Board of Directors of the Suffolk Lawyers for Justice (Dorchester's public defender group) at its September meeting. In addition, they have added to the Executive Committee one of the Suffolk Lawyers for Justice attorneys who lives in Dorchester and has the majority of his cases at Dorchester Court.

Primary JOD staff include:

- Training Director and Defense Attorneys, Committee for Public Counsel Services
- Attorney, Suffolk Lawyers for Justice
- Private local defense attorneys

Victim Service Providers

Victim services are provided by advocates in the Boston Police Department precincts, the Suffolk County District Attorney's Office, and various non-profit agencies. An important goal of the JOD project is to coordinate the services delivered by these agencies and facilitate the referral process.

The Executive Committee formed a Victim Services Subcommittee, which includes representatives of the many agencies providing victim services. The Subcommittee has held a series of facilitated meetings to provide cross-training on program goals and activities, define agency responsibilities and communication patterns, and set up referral systems.

Specific goals for the Boston Police Department advocates include developing and implementing an on-call program for immediate response, and implementing a block on caller ID so advocates can contact victims confidentially.

Advocates in the police department, called Peace Liaisons, are stationed within each precinct (one per precinct). A pilot program is scheduled to begin in the summer of 2001 in which the advocate in one of the precincts will carry a beeper for contact from responding officers. The officers will notify the advocate when an arrest has been made so that she can phone the victim immediately to assess safety and other emergency needs. The advocate will arrange to meet the victim the next day at the precinct station or courthouse, to provide assistance with immediate legal needs. Or the advocate may accompany a domestic violence detective to pick up the victim and take her to the courthouse the next morning. At the courthouse, the advocate and the detective will introduce the victim to the arraigning assistant district attorney and a district attorney's victim advocate, who will assist her/him with a restraining order application if she/he wants one. The caller ID block has been put in place.

Goals for the Suffolk County District Attorney's Office advocates include providing a variety of services to victims with criminal cases, as mandated by the state's Victim Bill of Rights. A caller ID block was also planned for these advocates. District Attorney's Office advocates are slated to participate in briefing sessions for restraining order plaintiffs to be held at the courthouse.

The District Attorney-based advocates continue to provide Victims' Rights services to victims through the Domestic Violence Unit and its dedicated staff. The caller ID block has also been put into place for these advocates. The restraining order plaintiff briefing sessions are still under planning; logistical issues needing resolution include severe limitations on courthouse space availability and the historical issue that victims come to court throughout the day rather than at one or two times. This makes it difficult to conduct organized briefings without delaying the victims unduly.

Non-profit community advocates have planned to enhance their services to restraining order plaintiffs by increasing courthouse-based staff and collaborating with District Attorney's Office staff on plaintiff briefing sessions. Other plans include expanding services to victims speaking languages other than English, and implementing caller ID blocks.

Non-profit organizations participating in the JOD partnership include the Dorchester Community Roundtable (an initiative, funded by the Centers for Disease Control and Prevention, that has been providing victim services in the community); Casa Myrna Vasquez (a comprehensive domestic violence victim service agency); and Northeastern University's Law Clinic (which provides assistance on civil

restraining orders). The Asian Task Force and the Association of Haitian Women in Boston are also providing services at the courthouse. A full-time Vietnamese advocate started in early June 2001, and the Haitian advocate started in July 2001. Services from these five agencies concentrate on restraining order plaintiffs. Courthouse space also presents an obstacle to the implementation of these services; space issues are being addressed in conjunction with the judiciary and clerk's office. Two offices and a conference room have been designated for victim services' use, and a third office is available most days.

In November 2000, the Dorchester Roundtable hired a full-time court-based advocate to perform triage functions with victims who go to the courthouse. She has a desk outside the restraining order clerks' office, where she meets with victims who enter the court. She provides initial services such as needs assessments and refers victims to advocates for specialized assistance on restraining orders (such as Northeastern University Law Clinic interns) and criminal matters (the District Attorney's Office advocates).

Case Myrna Vasquez has planned to hire a court-based advocate to provide civil legal assistance on restraining order matters. A full-time advocate was hired but has since resigned, so the search for a replacement is in process. In the interim, they have rotated other staff members to cover this advocacy position at the court. This agency is particularly adept at serving Spanish-speaking victims.

Northeastern University provides services primarily through law school student interns. These interns work on a part-time basis for an academic quarter, so that a new group of interns is in the court each quarter. These services are not available during breaks between quarters. A Clinical Supervisor was hired to train and supervise the interns under a Civil Legal Services grant from the Violence Against Women Office, but that grant expired in December 2000. Northeastern was not originally funded under JOD. However, the Clinical Supervisor position was added to the JOD budget. Northeastern has hired a person for that position who is working part-time during the summer and will be moving to full time in September. A professor also oversees the law clinic and student interns on a part-time basis.

It is widely agreed that the victim services component is at present understaffed, so that victims have not been getting the level of services planned. Not all victims enter the courthouse, and of those that do, not all meet up with the triage person or other advocates. Efforts to fill staffing gaps are planned, as discussed above. In addition, subcontracts are being executed with additional community-based advocates to expand services to victims. The Asian Task Force will provide services to Vietnamese victims. The Association of Haitian Women in Boston will service Creole-speaking Haitian victims. Victims speaking Cape Verdean Creole will receive services from the District Attorney's advocate who speaks Cape Verdean Creole or community-based agencies with this capacity.

The community-based organizations have been working, with the District Attorney's Office, on developing a briefing session for restraining order plaintiffs to be offered in the courthouse. This planning is still in process, and there is still some discussion as to whether briefings will be needed with full staffing. Caller ID blocks have not yet been obtained for the non-profit advocates.

JOD has been outreaching to additional community-based victim services organizations, including members of the faith community. In the refunding application, funds were included for Safe Haven, an interfaith group that trains faith-based organizations about domestic violence and how to help in these cases.

Primary JOD staff from non-profit organizations (others listed previously) include:

- Legal Services Coordinator, Director of Clinical and Community Services, and Domestic Violence Court Attorney, Casa Myrna Vasquez
- Executive Director and Triage Victim Advocate, Dorchester Community Roundtable
- Director, Clinical Teaching Fellow, and Interns, Northeastern University Law School Domestic Violence Clinic
- Executive Director, Acting Program Director, and two Advocates, Asian Task Force
- Director, Family Advocate, and Advocate, Association of Haitian Women

JOD Implementation Timeline

April 2000	Strategic planning meeting for all JOD partner agencies
May 2000	Boston Police Department (primary grantee) received financial clearance from the Office of the Comptroller
August 2000	Casa Myrna Vasquez hired Legal Advocate (since resigned)
August/September 2000	District Attorney's Office hired three additional Assistant District Attorneys for Domestic Violence Unit
September 2000	Domestic Violence Court (Second Session) began
October 2000	Project Director and Site Evaluation Coordinator hired
October 2000	Funds awarded to Massachusetts Trial Court for probation component available
November 2000	Probation Office hired four additional Probation Officers for Domestic Violence Unit
November 2000	Dorchester Roundtable's Triage Victim Advocate hired
December 2000	Probation Office hired two additional Assistant Probation Officers for Domestic Violence Unit
March 2001	Probation reviews began
May 2001	All-court in-service training on JOD initiative held
June 2001	Strategic planning meeting and cultural competency training for all JOD partner agencies
June 2001	Asian Task Force Advocate hired to provide services at the courthouse
July 2001	Briefing sessions for restraining order respondents began
July 2001	Association of Haitian Women Advocate hired to provide services at the courthouse

Milwaukee, WI

The City of Milwaukee has a population of about 600,000 (about 55 percent minority) and is the largest of 19 municipalities in Milwaukee County. The population of the entire county is approaching 1,000,000. Domestic violence is a serious problem in the county with approximately 9,000 charges reviewed in 2000 (90 percent of them from the City of Milwaukee). Almost 60 percent of the charges are issued. Approximately 65 percent of the defendants are African-American, 33 percent Caucasian, and about 2 percent are Hispanic/Latino, American-Indian, and Asian. Eighty-five percent of the defendants are male.

Milwaukee's selection as a demonstration site for the Judicial Oversight Demonstration initiative followed a 20-year commitment in the city and county to the problem of domestic violence. In 1979, Milwaukee formally established its coordinated community response in the name of the Commission on Domestic Violence and Sexual Assault. In 1986, a pro-arrest policy was initiated in Milwaukee; three years later, the state adopted a mandatory arrest policy. Milwaukee was previously involved in national research and evaluation on domestic violence, including being one of the replication sites for the Minneapolis Domestic Violence Study and one of the first demonstration sites for domestic violence initiatives funded through the Centers for Disease Control and Prevention (with funding from the Violence Against Women Act).

In 1994, Milwaukee initiated specialty court dockets for domestic violence, and in 1997 Milwaukee received a 5-year grant from the Violence Against Women Office for two specialized domestic violence prosecutors, three victim/witness specialists, and contractual payments to community-based victim service organizations to enhance services and advocacy to victims. In 2000, Milwaukee received \$194,840 from Wisconsin STOP (Services, Training, Officers, Prosecutors) grant funds for one prosecutor, one victim/witness specialist, two hourly process servers for subpoenas in domestic violence cases, and one sexual assault victim advocate. Also during this period, the Milwaukee Women's Center received a five year domestic violence prevention demonstration grant from the Centers for Disease Control and Prevention which included funding for batterer intervention program services and evaluation. The information gained from the Safe at Home project helped Milwaukee to identify needs and gaps in batterer accountability services and the administration of these programs.

Partner Agency Profiles Prior to Implementation of JOD

Milwaukee's approach to JOD involves five government agencies – Circuit Court, Office of the District Attorney (including victim/witness specialists), Domestic Violence Crisis Response Unit (new with JOD), Office of the Public Defender, Milwaukee Police Department, and the Division of Community Supervision (within the Wisconsin Department of Corrections). In addition, as a separate unit, the Office of the Chief Judge has management responsibilities for the court system in Milwaukee. Four non-governmental service providers complete the JOD partnership in Milwaukee: Task Force on Family Violence, Milwaukee Women's Center, Sojourner Truth House, and Asha Family Services. The sections below describe the operations of each of these agencies prior to the implementation of the Judicial Oversight Demonstration Initiative.

Milwaukee Circuit Court

Description

In 1994, Milwaukee County designated its first Domestic Violence Court within the Misdemeanor Criminal Division to hear domestic violence cases. Two additional courts were added in 1995 after the Milwaukee County District Attorney's Office implemented a more aggressive "no-drop" prosecution policy in domestic violence cases, in response to a Wisconsin state statute. The new prosecution policy resulted in a charging rate of approximately 60 percent, as compared to 20 percent before the change and produced an increase of about 30 percent in misdemeanor court filings. In these courts, the caseload is highly dependent on the presiding judge, but prior to the initiation of JOD for 2 months in 2000, an average monthly caseload was about 450 cases, with approximately 100 new cases a month. All three courts were included in the Milwaukee County speedy trial project with the goal of completing cases within 90 days of the defendant's initial appearance in court. In 1999, approximately 58 percent of the cases that resulted in convictions were completed in less than 90 days, and 83 percent were completed in less than 150 days. In 2000, 59 percent were resolved in 90 days and 90 percent were resolved in 6 months.

The initial appearance for in-custody misdemeanor and felony domestic violence cases is conducted within 48 hours of the incident, 7 days a week, in intake court, presided over by a general Court Commissioner (no specialized docket). The majority of defendants enter not guilty pleas at this stage and a pretrial appearance is scheduled for 2 to 3 weeks later in the domestic violence court. The intake court commissioner has routinely issued "no contact" orders, but monitoring of these orders was limited. At any pretrial appearance, a guilty plea can be accepted, but if the victim is not present, the case must be set for sentencing in order for the victim to be contacted (per state law). If a not guilty plea is entered, the case is set for a jury trial.

In the last several years, about 50 percent of misdemeanor domestic violence cases have been dismissed after charging due to lack of evidence, which frequently occurs because the victim has recanted or refuses to cooperate and the prosecution has no other evidence. The typical sentence for convicted defendants is either a jail sentence or probation. Sentences to probation have virtually always included a requirement to attend a batterer intervention program and/or substance abuse treatment (one or the other or both in at least 85 percent of cases in 1999). Prior to JOD, the court did not mandate reports from the intervention providers regarding progress in these programs. Completion of an intervention program was monitored by probation and if compliance with this condition was a problem, the probation officer could initiate revocation proceedings.

Prior to the demonstration project initiation, judges had been assigned to the domestic violence court for a period of one year and they usually received training in the area of domestic violence. However, judges appeared to rotate out of the domestic violence court just as they had been trained and become comfortable with the assignment.

Available baseline data for 1998–2000 combining law enforcement, prosecution and court responses to misdemeanor domestic violence in Milwaukee County show that there has been a stable decline in the number of charges reviewed and subsequently issued, approximately 15 and 20 percent respectively, over the three-year period. The charging rate (percentage of reviewed arrests that are charged) has declined slightly from 63 percent to 58 percent. Convictions as a percentage of disposed cases have remained relatively constant at about 50 percent. For convicted batterers in Milwaukee, a jail sentence is common – about 50 percent of batterers are sentenced to jail. The number of deferred prosecution agreements negotiated between the District Attorney and the defendant has dropped sharply, presumably because a revised procedure for deferred prosecution agreements, planned as a part of JOD, was being finalized in 2000.

Data on the number of restraining orders requested show a slight decline in the number of persons requesting restraining orders and the number of orders issued.

Domestic Violence Charges/Cases	1998	1999	2000
Charges reviewed	10,721	9,277	8,999
Charges issued	6,777 (63%)	??	5,249 (58%)
Disposed charges	6,089	??	5,353
Disposed cases	5,031	4,839	4,416
Bench/jury trials	Not available	Not available	Not available
Case convictions	2,629 (52%)	2,217 (46%)	2,263 (51%)
Case dismissals	2,344	2,543	2,128
Jail sentences*	1,472	1,303	1,342
Deferrals (deferred prosecution agreements)	58	79	25

*based on charge; about 1.2 charges per case

Restraining Orders	1998	1999	2000
Persons Served	4640	3941	4300
Orders Issued	4874	4073	4554

Similar data are being collected on a monthly basis beginning in January 2001. Future reports will present these data and compare them with this baseline information.

Prior Relationships with other Agencies

The Court's relationship with agencies involved in pretrial supervision or post-sentence monitoring of domestic violence offenders was limited prior to the implementation of JOD. In the pretrial period, for example, it appears that referrals for alcohol and drug monitoring were infrequent. The Court relied on information from the District Attorney's Office for identifying defendants out on warrant or with probation violations.

Victim advocates rarely appeared in court and few victims were present at the initial appearance, pretrial appearances, or trial. Victims were notified of their legal right to be present and speak at sentencing, but few victims appeared. Judges did regularly issue "no contact with victim" and "no violent contact with victim" orders for offenders sentenced to probation. However, the court did not have a system for periodic post-conviction review of compliance with these orders.

The Court also had limited contact with batterer intervention programs. Judges may have ordered offenders to batterer intervention programs, but the responsibility rested on the Division of Community Corrections to conduct an assessment and make a specific referral. Frequently, entry into batterer intervention was delayed after the incident (an average of 9 months based on data from 1998-99). In some instances, offenders would wait as long as possible during their probation to make contact with the program, and then often not complete it if their probation period ended before the end of the program. Fifty percent of offenders with a condition to enroll in a batterer intervention program never showed up at for intake. Lack of program capacity was also a problem. Finally, as mentioned above, there were no post-conviction review hearings during the probationary period, unless the agent initiated revocation proceedings.

Office of the District Attorney

Description

Since 1987, the District Attorney's Office has maintained a special domestic violence unit. It included seven prosecutors prior to the implementation of JOD and attorneys reviewed misdemeanor domestic violence charges within 24–48 hours of the incident, 7 days per week, based on the police report. There has been no specialized review for felony cases.

Following Wisconsin state law, the Office practices a “no drop” policy, which states that victim cooperation should not be considered in the charging decision and that the case should proceed on the facts of the incident, not the likelihood of the victim's testimony. If charges are issued and the defendant is in custody, he appears in intake court before a Court Commissioner. If the defendant is not on the scene, and hence not in custody, a warrant is issued for the defendant to appear within 24 hours. The Office makes recommendations to the Court for bail amount and conditions of release. Prior to JOD, felony domestic violence cases were prosecuted in six general felony courts by the 18 members of the District Attorney's general felony team who lacked experience in domestic violence and were often overwhelmed by large caseloads. Vertical prosecution methods were used by one prosecutor in the unit who was assigned to handle difficult misdemeanor cases.

As presented above, the charging rate for the District Attorney's Office averaged 55–60 percent in 1998–2000. There were about 1.2 charges per case/defendant.

Prior Relationship with other Agencies

The District Attorney's Office has been regularly involved with many of the agencies in the JOD partnership for many years. The Milwaukee Police Department maintains a liaison office in the District Attorney's Office which is responsible for reviewing the incident and arrest reports for completeness and accuracy and preparing the files for the District Attorney's review. Liaison officers with the Department of Corrections, Division of Community Corrections (probation) worked in the District Attorney's Office to screen new cases for defendants with probation violations.

Prior to JOD, a domestic violence victim/witness unit affiliated with the District Attorney's Office worked with victims on all charged cases. Two victim/witness advocates were assigned to each of the three domestic violence courts. Their responsibility was to secure victim cooperation, maintain regular contact with the victim, inform her of the progress of the case, and provide all contacts as mandated by the state victim rights legislation. However, as noted above, few victims appeared in court for any proceedings involving their case, including for trial. (Supporting data are not available, but court personnel agree that victim appearance rates certainly do not exceed 50 percent.) In addition, victim advocates from two non-profit community agencies have had offices in the courthouse – Asha Family Services and Sojourner Truth House. (Asha's office in the courthouse was closed in Fall, 2000.) These community agencies make contact with victims and discuss needs or make referrals for a variety of services including housing, counseling, child issues, and general assistance.

Milwaukee Police Department

Description

The Milwaukee Police Department has operated under a mandatory arrest policy for misdemeanor and felony domestic violence since 1986, three years prior to Wisconsin's state statute requiring such arrests. All officers in the Milwaukee Police Department receive training in handling domestic violence calls in the Academy and at regular in-service training sessions; officers on duty respond to domestic violence calls as dispatched.

There has been a 16 percent decline in the number of charges brought for misdemeanor domestic violence by the Milwaukee Police Department between 1998 and 2000.² This stable decline in numbers of charges brought (and subsequently issued by the District Attorney) parallels a general decline in arrests in Milwaukee County. Whether the incidence of misdemeanor domestic violence has actually decreased in the county is not known.

Year	Calls to Hotline from Milwaukee Police Department and County Agencies	Domestic Violence Arrests
1998	9,845	Not available
1999	8,593	Not available
2000	7,751	Not available

Prior Relationships with Other Agencies

The Milwaukee Police Department has collaborated with the District Attorney's Office on investigation of cases, although a lack of resources meant that follow-up investigation on misdemeanor domestic violence cases was often difficult to obtain. The Milwaukee Police Department routinely testifies at criminal trials or evidentiary pretrial hearings, but is not present at sentencing.

Since 1986, the Milwaukee Police Department has been required to call the local domestic violence hotline maintained by Sojourner Truth House to connect the victim to non-governmental service providers in the community. The officer at the scene also provides the victim with written information regarding community resources.

² In addition, the number of requests for restraining orders, calls to the domestic violence hotline and requests to non-governmental agencies for service have also declined during this period.

Office of the State Public Defender

Description

Attorneys from the Office of the State Public Defender and a group of attorneys from the community assigned to indigent defendants have represented about 33 percent of defendants charged with misdemeanor domestic violence cases in Milwaukee County. Prior to JOD, domestic violence cases were not given any special treatment in the office.

The office is unable to provide data on the number of domestic violence defendants, which were represented prior to the initiation of JOD.

Prior Relationships with Other Agencies

Prior to JOD, the Public Defender's Office had what might be referred to as "typical" working relationships with the other criminal justice agencies (the District Attorney, law enforcement, and probation), and virtually no contact with service providers, especially those working with victims.

Division of Community Corrections, Department of Corrections

Description

Probation supervision in Milwaukee County is handled by the Division of Community Corrections within Wisconsin Department of Corrections. In recent years, the Division of Community Corrections has been faced with increasing caseloads which have precluded the routine, frequent contact necessary for effective monitoring of convicted batterers.

The Division does not have a separate probation unit for domestic violence cases, rather the department uses a system of dedicated domestic violence specialists in each of the field offices. Domestic violence specialists are provided specific training on domestic violence issues, including appropriate methods of supervision, interacting with victims, community resources and programs. These specialists also serve as consultants for other agents about cases in which domestic violence is a concern, although not the conviction offense.

Data on violations and revocation proceedings prior to JOD for domestic violence cases are not available; the probation data system has no method for identifying these cases.

Prior Relationships with Other Agencies

Prior to JOD, the relationship between the court and probation was limited. Because of the heavy caseload, judicial review of offenders who failed to comply with the terms of their probation was infrequent. The only alternative was to initiate revocation proceedings, which is a lengthy, time-consuming process for the courts and the probation agents.

For the District Attorney's office, liaison officers from the Division are routinely assigned there to review new cases and identify domestic violence offenders on probation who are arrested and charged with new offenses.

Community Service Providers

Description

Four non-profit, domestic violence providers are active in Milwaukee: Sojourner Truth House, Asha Family Services, Milwaukee Women's Center, and the Task Force on Family Violence. Each agency provides intervention services for both victims and offenders. Available services are comprehensive and include shelter for women and their children, legal advocacy, housing and financial assistance, victim support groups, and intervention programs for batterers. However, service providers recognized that many victims were not receiving services and were confused by the array of providers in the community and how to seek services. Programs for batterers were of varying length, philosophy, and content, and over half of the offenders did not report for an intake interview as ordered by the court. The average time from date of offense to program enrollment was over 9 months.

Prior Relationships with Other Agencies

Prior to JOD, officers on the scene of a domestic violence call notified the local domestic violence hotline managed by Sojourner Truth House but victims were not routinely contacted by a service provider for one-on-one assistance. Also, one of the non-governmental agencies — Sojourner Truth House — provided assistance to domestic violence victims entering the District Attorney's Office seven days a week. However, advocates accompanied victims to court infrequently.

For the offenders, most of the referrals into the batterer intervention programs were part of a criminal sentence and were managed by probation agents. However, reports concerning progress in batterer intervention programs were not routinely given to probation and procedures for such feedback varied considerably among the four agencies.

Baseline data on service delivery for these agencies is not readily available. Proxy measures, such as number of persons who applied for restraining orders (facilitated in large part by the Task Force on Domestic Violence) and the number of calls placed to Sojourner Truth House from the Milwaukee Police Department provide a benchmark.

Milwaukee JOD Initiative

Description

Milwaukee's approach to the Judicial Oversight Demonstration Initiative builds on a number of domestic violence initiatives that began in the early 1990s. After a thorough needs assessment, the JOD planning committee in Milwaukee identified a series of gaps in the county's response to domestic violence, from law enforcement and investigation to prosecution, defense, and judicial operations to capacity in service provision. Each JOD enhancement has been specifically designed to address an identified need. Figure 5 illustrates the central role of the court in the Milwaukee JOD initiative and the various JOD partner agencies.

As a grantee of the Judicial Oversight Demonstration Initiative, Milwaukee County received \$1,998,257 for the period October 1, 1999 to March 31, 2001. The award reflects a 6-month Phase I planning and capacity building period, and a Phase II 12-month operational budget. The grant is continuing to operate through September 30, 2001 on a no-cost grant extension. The grant proposal specified support for the project director, site evaluation coordinator, Domestic Violence Crisis Response Unit's team (6 staff members and one clerical position), domestic violence court resource monitor, research assistant, court commissioner, two clerks and one bailiff, two specialized pretrial agents, four assistant district attorneys, domestic violence investigation and equipment for the Milwaukee Police Department, additional victim services and batterer intervention program capacity (\$100,000 to each of four agencies in the first year), approved travel and technical assistance, and administrative costs.

Anticipated Outcomes

Milwaukee County hopes that the implementation of JOD as envisioned in the grant proposal will lead to: (1) faster disposition of cases, (2) increased conviction rates, (3) increased felony charging and conviction rates, (4) increased issuance of charges for bail violations, (5) increased participation of victims in the court process, (6) reduced average time from sentencing to issuance of warrants for offenders who abscond from probation, (7) reduced average time from conviction to revocation for probation violators, (8) reduced average time from incident to entry into batterer intervention program, and (9) reduced recidivism.

Ten system changes and two communications enhancements comprise the proposed Milwaukee JOD Initiative. These are discussed in detail in the sections which follow.

System Changes

- Implementation of a Domestic Violence Crisis Response Unit to provide immediate response to domestic violence victims and on-going case management for cases originating in 2 of 7 police districts;
- Addition of a dedicated, 5-days-a-week domestic violence Court Commissioner in a separate court to handle all pretrial appearances (after initial appearance) and oversee intensive pretrial monitoring of defendants;
- Expanded prosecution capacity from a domestic violence team of about 7 Assistant District Attorneys to 11 (addition of 2 each for misdemeanor and felony prosecutions);
- Expanded offsite evening and Saturday hours for restraining order filing;
- Specialized domestic violence detectives and investigative equipment;

- Revised deferred prosecution agreements and training for defense bar;
- Implementation of specialized pretrial supervision unit for cases originating in 2 of the 7 police districts through the hiring and training of two pretrial agents;
- Expanded capacity for community service providers to assist domestic violence victims and offenders by providing subcontracts to four existing service agencies;
- New domestic violence court resource monitor to manage domestic violence caseload after conviction and sentencing to ensure that judges' orders are implemented; and
- Initiation of post-conviction, in court, probation reviews 60 to 90 days after sentencing.

Communications Enhancements

- Enhanced structure for community domestic violence coordination and planning;
- Implementation of a tracking system maintained by the court to promote communication between court, probation officers, and batterer/substance abuse service providers.

Figure 4 depicts Milwaukee's case flow and their planned enhancements for their JOD initiative. Figure 5 illustrates the partner agencies involved in Milwaukee's initiative.

Figure 4.
Milwaukee Processing of Misdemeanor Domestic Violence Cases: Planned JOD Enhancements

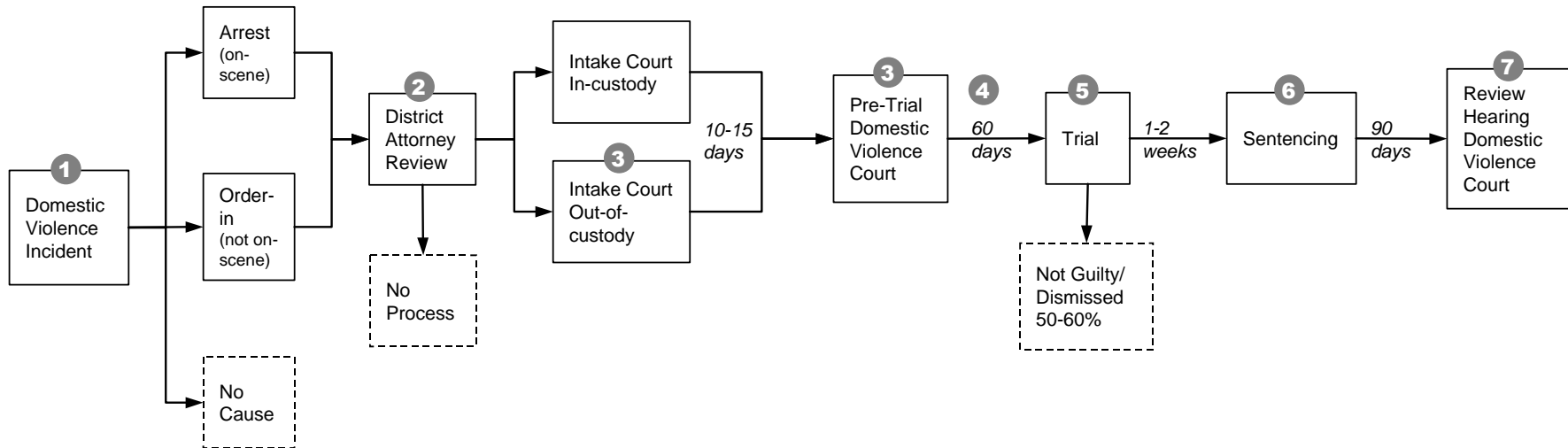

Primary JOD Enhancements (Proposed)

- ① Domestic Violence Crisis Response Unit notified in Milwaukee Police Department Districts 2 and 3
- ② 4 New Assistant District Attorneys; vertical prosecution; deferred prosecution review/offer
- ③ New domestic violence Court Commissioner hears these cases and handles all pretrial hearings
- ④ Pretrial monitoring of defendants from Districts 2 and 3 by special probation agents, including pretrial status hearings
- ⑤ Special investigation if needed by Milwaukee Police Department's Sensitive Crimes Unit
- ⑥ Court Resource Monitor tracks domestic violence offenders for court (see text)
- ⑦ Domestic violence Judge conducts mandatory probation status review hearings and responds to violations (all cases)

Figure 5.
Milwaukee: JOD Network of Partners

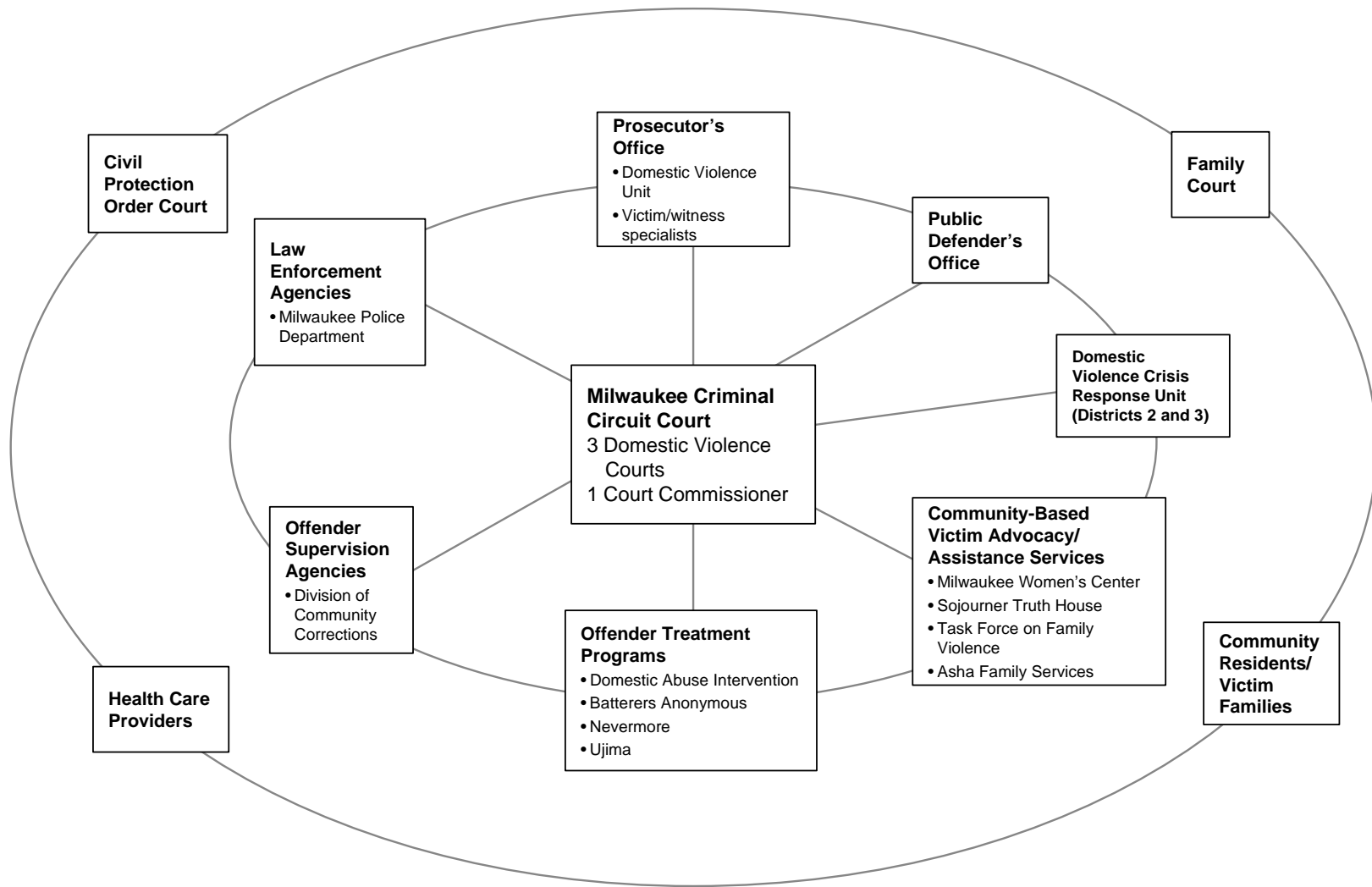

Planned Agency Changes and Initial Implementation

After Milwaukee received the JOD award in October 1999, the project moved quickly towards implementation, even though an 18-month planning and development phase was built in to the grant. Some of the planned changes were implemented as early as May 2000. (An implementation timeline with the critical milestones in the implementation process is presented at the end of this chapter.) For each of the participating components, the planned changes for JOD and the implementation progress since grant award is discussed.³

As part of the planning process for JOD in Milwaukee, the JOD Advisory Committee was created with several subcommittees charged with discussing the steps involved in implementing specific components of JOD as proposed in the grant application submitted by Milwaukee. The subcommittees in particular appeared to be quite constructive groups for resolving inter-agency disputes and hammering out new procedures. The initial implementation plans were presented to all JOD partner agencies at a JOD implementation planning meeting in August 2000.

³ These sections are based on documents provided by the site, including the original grant application and other materials prepared for continuation funding, site visits conducted in 2000-01, interviews with JOD participants, discussions with the technical assistance provider (The Vera Institute), and a review of available JOD monthly tracking data.

Milwaukee Circuit Court Office of the Chief Judge

Planned Changes for JOD

The Chief Judge of the Court has primary responsibility for creating the management structure, positions, and responsibilities for the design and implementation of JOD. The Project Director, located in the Circuit Court and reporting to the Chief Judge, is working with the partner agencies to shape the demonstration and guide its implementation. The Site Evaluation Coordinator is also located in the Circuit Court. As a court-focused demonstration, the planned enhancements to the operations of Milwaukee's Circuit Court for JOD are substantial.

The four primary elements of the court component are:

1. The addition of a fourth dedicated court in the misdemeanor division with a new Court Commissioner for domestic violence cases who will hear all pretrial proceedings, including pretrial appearances after the initial appearance, bail reviews, and status appearances, 5 days a week. The Commissioner will take pleas, set bond and bail conditions, and refer defendants for immediate sentencing if a guilty plea is entered.
2. A pre-trial supervision program for defendants from police districts 2 and 3 which will utilize two specially-trained probation agents to monitor defendants' compliance with bail conditions. Defendants will meet in-person with an agent within 24 hours of release from custody, agree to be contacted regularly during the pre-trial period, and appear in court for reviews every 7 to 14 days. The agent will also contact the victim to assess compliance with bail conditions, such as "no-contact" orders. Violations of pretrial conditions will be met with immediate court review and a system of graduated sanctions.
3. Initiation of mandatory post-conviction review hearings of compliance with conditions of probation for domestic violence offenders which will occur within two to three months of sentencing. Judges will review a supervision status report submitted by the probation officer, sanction offenders for violations (including time in custody and possibility of revocation of probation), and issue arrest warrants for absconders.
4. The proposed addition of a new court position, the Domestic Violence Court Resource Monitor. The proposed duties included serving as a liaison between the court and probation by formalizing the conditions of probation with the defendant immediately after sentencing (including assignment to a batterer intervention program), receiving the probation status reports, tracking defendants who negotiate a deferred prosecution agreement, and updating defendant court records.

In addition to these four primary court changes, two other enhancements are likely to fill important gaps in services for victims in Milwaukee: 1) a private waiting area in the courthouse for victims and their children, and 2) a satellite location for filing protection orders in evenings and on weekends, in donated space from a local hospital.

Primary staff for JOD within the Milwaukee Circuit Court include: Domestic Violence Circuit Court Judges (3), Domestic Violence Court Commissioner, JOD Project Director, JOD Associate Project Director, and JOD Local Site Evaluation Coordinator.

Staff in the Office of the Chief Judge: Chief Judge, Milwaukee County Court Administrator, and Deputy Court Administrator.

JOD Implementation Progress

After the grant was awarded, the Milwaukee Circuit Court moved quickly to initiate the post-conviction status hearings for those sentenced to probation. The judges, who advocated for the hearings, are pleased with the process, although the hearings initially produced some strain on the probation officers (who were in the process of working out new procedures) and caused a sharp increase in referrals to batterer treatment programs. The court is responding to probation violations with a system of graduated sanctions. Preliminary data (January–March 2001) indicate that about 20 percent of defendants have been revoked, recommended for revocation, issued an arrest warrant for failure to appear, or are in custody on other matters; another 30 percent remain on probation but have violated one or more conditions; and approximately 50 percent are in compliance.

The arrival of the new Domestic Violence Court Commissioner altered court procedures but these changes have been incorporated smoothly into the court's routine. The dedicated domestic violence court commissioner has freed the judges to spend more time with bench and jury trials, permitted sentencing hearings to occur sooner, and provided time for the new post-conviction reviews. In the first two months of 2001, the number of new filings and disposed cases has remained relatively constant to a similar period in 2000, but the average time to disposition has been significantly reduced (65 percent resolved in 3 months vs. a pre-JOD rate of 53 percent), suggesting a positive impact of JOD on the efficiency of the courts.

A pilot pretrial supervision program was successfully negotiated with the defense bar. The pretrial review hearings for defendants arrested in Districts 2 and 3 began in May 2001 and defendants appear before the Domestic Violence Court Commissioner every two to four weeks during a typical 60 to 90 day pretrial period. Sanctions can be imposed for violations including failure to appear for hearings.

Also proposed as a court enhancement was a new court position, the Domestic Violence Court Resource Monitor. It appears that this position will not be filled because of budget cuts imposed for the second year of project funding. Some of the proposed duties for this position will be carried out by the JOD Associate Director.

The positions of Associate Project Director and Local Site Evaluation Coordinator have also been the subject of staffing problems and hiring delays. The lack of continuity in these positions has increased the workload of the Project Director and reduced her ability to coordinate the work of all the JOD partner agencies and resolve outstanding implementation issues.

Other accomplishments in the initial implementation period include the creation of a waiting room within the courthouse for victims and their children and the initiation of an off-site location for requesting emergency protection orders during some evenings and on Saturday.

Office of the District Attorney

Planned Changes for JOD

In the District Attorney's Office, a number of changes were planned to enhance the strength of charged cases, reduce case dismissals, and reduce time to disposition. The three primary changes are:

1. The addition of four assistant district attorneys (two of whom handle felony cases) to increase the Office's capacity for prosecuting misdemeanor and felony domestic violence cases and to enhance the vertical prosecution of complex misdemeanor and felony domestic violence cases. Two assistant district attorneys are assigned to each of the four courts, two for handling felony cases, and one for handling complex misdemeanor cases.
2. An enhanced focus on thorough documentation of the incident, including requests to the Milwaukee Police Department Sensitive Crimes Unit for special follow-up investigation on specific cases. New equipment will be purchased to enhance these investigations (e.g., digital cameras).
3. New procedures for and greater use of deferred prosecution agreements. Conditions under which a deferred prosecution agreement can be granted would be modified to reduce perceived racial disparity in the offer of deferred prosecution agreements and increase the likelihood that some defendants will choose this sanction and accept responsibility for the incident, in exchange for dismissal of the charges and other incentives.

Primary staff include the District Attorney, Head of the Domestic Violence Unit, 11.5 prosecutors, six victim/witness specialists, two paralegals, one complaint evaluator, two hourly process servers, and three secretaries.

JOD Implementation Progress

The District Attorney's Office has completed all planned hiring for the Judicial Oversight Demonstration Initiative. With the additional attorneys, felony domestic violence cases are now separated from the regular felony criminal caseload and are prosecuted by attorneys who have experience with domestic violence cases. These cases are now heard in the domestic violence courts. Vertical prosecution of felony cases and some complex misdemeanor cases is also occurring more regularly.

After protracted discussions, a revised deferred prosecution agreement was reached with the Office of the Public Defender, private bar, probation, and batterer intervention programs. The standards of eligibility have been revised such that the pool of eligible defendants will be greatly expanded. The new deferred prosecution agreement will be offered to defendants meeting the requirements on a case by case basis; defense attorneys may also request consideration of a deferred prosecution agreement.

Prosecutors believe that these JOD enhancements are resulting in a higher charging rate, fairer plea offers, a higher quality of prosecution because of the more experienced attorneys, and higher conviction rates. These outcomes are being monitored using the monthly data submitted by the Office and will be included in monthly feedback reports to the site. In addition, the Office is increasing its contact with victims in charged cases, but they would like to see greater numbers of victims involved in the court process.

Milwaukee Police Department

Planned Changes for JOD

The Milwaukee Police Department's responsibilities in JOD include special procedures for arrests in Districts 2 and 3 (see discussion of Domestic Violence Crisis Response Unit below), training, follow-up investigation of domestic violence cases as requested by the District Attorney (using additional funds for overtime), and purchase of equipment to assist in the investigation of domestic violence cases (e.g., digital cameras). New in JOD, the Milwaukee Police Department will train and assign officers from the existing Sensitive Crimes Unit to carry out follow-up investigations of domestic violence cases, as requested by the District Attorney's Office.

In 2000, about 12 percent of the arrests for domestic violence in Milwaukee County came from suburban police districts outside the city limits. The largest of these is the West Allis Police Department. Several of the JOD partner agencies, including the District Attorney's Office and the Chief Judge, have discussed the JOD model with the county law enforcement agencies. Discussions are focused on achieving consistency in the response to domestic violence throughout Milwaukee County.

Primary staff include the Police Chief, Deputy Chief (JOD liaison), Lieutenant (responsible for JOD monthly data collection), Captain of the Sensitive Crimes Unit, and Captains from Districts 2 and 3.

JOD Implementation Progress

The Milwaukee Police Department signed a Memorandum of Understanding with the Judicial Oversight Demonstration Initiative, which outlined the department's responsibilities with JOD. It was initially negotiated that for domestic violence calls occurring in districts 2 and 3, the new Domestic Violence Crisis Response Unit would be called immediately once the scene was secure. Advocates from this unit would come to the scene of the arrest while the officer(s) were present. However, the officers have not been able to remain at the scene until the advocates arrive, and the JOD Project Director is negotiating new procedures for domestic violence calls in Districts 2 and 3.

The Milwaukee Police Department's liaison to the District Attorney's Office is working to strengthen charged cases by gathering additional information from the arresting officer, if needed. The District Attorney's Office can also request special investigation by the Sensitive Crimes Unit of the Milwaukee Police Department. The use of the Sensitive Crimes Unit was pilot tested with charged cases in Districts 2 and 3 and expanded to include cases from all districts in May 2001.

One source of frustration for the Milwaukee Police Department is the high rate of case dismissal in the trial stage. Officers appear for over 90 percent of these trials, usually charging overtime for their appearance. It is hoped that a closer working relationship between the police department and the Office of the District Attorney will strengthen these cases and lower the dismissal rate.

Office of the State Public Defender

Planned Changes for JOD

In coordination with the Office of the District Attorney, the Public Defender's Office agreed to negotiate new procedures for deferred prosecution agreements, including expanded eligibility criteria and increased incentives for accepting such agreements. The private defense bar has also been brought into these discussions.

Although JOD cannot provide resources to the Public Defender's Office under the federal guidelines of the grant, the project is working on strategies for providing resources to the Office to help with the specialized courts, increased caseload, and new procedures that are being implemented under JOD.

JOD will also facilitate additional training for the private defense bar in Milwaukee on JOD and the planned changes in the court response to misdemeanor domestic violence cases.

Primary staff include the Public Defender, Assistant Public Defender (JOD liaison), and staff attorneys.

JOD Implementation Progress

The Office was very involved in the initial JOD planning and continues to work closely with the other JOD partner agencies on issues affecting the defense role in the project. The Public Defender's Office successfully negotiated procedures for a revised deferred prosecution agreement with the District Attorney and the new procedures were in place as of July 2001. Several internal training sessions have occurred with the attorneys in the office and with invited private attorneys.

The impact of JOD on the Public Defender's Office has been primarily through extending the length of time that the Office is representing their clients because of the probation status hearings after sentencing. The Office must also make additional court appearances for those defendants in the pilot pretrial monitoring program.

JOD has also greatly increased the contact the public defender attorneys have with the court, the district attorney's office, individual judges, and probation agents. Batterer intervention providers have some limited contact with the Office; the Public Defender would like to arrange a joint workshop to enhance understanding of each other's role.

Department of Corrections, Division of Community Corrections

Planned Changes for JOD

The probation component of the Milwaukee JOD plan is a critical part of the project as it is intended to create a stronger relationship between the court and probation services than existed prior to JOD. Two of the key planned changes for JOD in Milwaukee involve the Division of Community Corrections: pretrial monitoring and post-conviction hearings.

As mentioned previously, the court proposed a pilot program of specialized pre-trial supervision for all defendants from police districts 2 and 3. Two specially-trained agents will monitor these defendants for compliance with conditions of bail or bond release. Caseloads of about 30–40 are expected.

Second, a post-conviction court appearance approximately two to three months after sentencing will be required of all defendants placed on probation. Probation agents who specialize in domestic violence cases will be assigned to these offenders, although a domestic violence unit within the Division of Community Corrections is not planned. Agents will prepare a supervision status report prior to the hearing which will include information on batterer intervention referral and program attendance.

Primary staff include the Regional Chief, Assistant Regional Chief, two probation officers assigned to pretrial monitoring, a supervisor of the pretrial unit, and approximately 25 probation officers who handle the majority of misdemeanor domestic violence offenders sentenced to probation.

JOD Implementation Progress

In May 2001, the pilot pretrial supervision program was initiated. (The initiation of the pretrial monitoring component was delayed several months because of state regulations regarding approval for new positions and hiring processes.) Procedures for implementing the pretrial monitoring component were the focus of protracted negotiations involving prosecution, defense, and community supervision (probation). At issue was the types of conditions which are constitutionally permitted during this period, and how compliance could be monitored. Hence, there are limitations on the questions that can be asked of defendants by the pretrial agents and these agents cannot take a defendant into custody for a bail violation. Anecdotal evidence suggests that the pretrial supervision and status hearings may be reducing violations and hence, improving defendant accountability in the pretrial period. The pretrial supervision program and the contacts pretrial agents make with victims may also be eliciting greater cooperation from the victims. Both victims and defendants seem to be gaining a greater understanding of the court process through the pretrial supervision program.

One of the first components of the JOD Initiative to be implemented in Milwaukee was the probation status review hearings for all batterers on probation, approximately 60 to 90 days after sentencing. These hearings are scheduled for Friday afternoons in front of the sentencing judge. The batterer and his or her probation officer must be present. Several days prior to this hearing, the probation officer sends a report to the judge on the batterer's compliance with conditions of probation, especially the no contact orders and enrollment and attendance at a batterer intervention program. Initial data (January–March 2001) show that 44 percent of batterers were revoked or received enhanced probation conditions, including short jail stays (average stay was 12 days), additional review hearings, or imposition of the full sentence.

Implementation of the planned changes in the probation component of JOD has clearly resulted in greater communication between probation and the court. Moreover, probation agents are working more closely with the batterer intervention programs in Milwaukee to identify offenders who are not in compliance with conditions of their probation. This increased communication is intended to hold offenders accountable for their behavior and to ultimately reduce repeat violence by these offenders. Baseline data on the percentage of offenders who were sanctioned for probation violations prior to JOD would be useful to document changes that may be occurring in offender behavior due to the implementation of the probation component of JOD.

Community-Based Service Providers

Planned Changes for JOD

The JOD enhancements for service providers in Milwaukee focus on improving services to victims by coordinating the various services in the community through the development of a case management model to ensure victim safety and access to services, increasing service capacity, and strengthening batterer intervention services in the community.

The centerpiece of these enhancements is the creation of the Domestic Violence Crisis Response Unit, a separate county agency created for JOD. As proposed, the unit's emergency responders would provide immediate, on-scene support to victims of domestic violence residing in police districts 2 and 3 following a police response. In addition, staff from the Domestic Violence Crisis Response Unit would provide referrals to community service providers and assistance with court hearings, transportation, emergency housing, counseling, etc.⁴

In addition, the JOD Initiative in Milwaukee, working through the four existing community service providers – Sojourner Truth House, Asha Family Services, Inc., Task Force on Family Violence of Milwaukee, Inc., and Milwaukee Women's Center, Inc. – identified a variety of service needs for victims and offenders, including:

1. Additional capacity for services to victims and offenders. This includes hiring additional staff, expanding support programs, and increasing capacity of the batterer intervention programs;
2. Immediate referral and entry to an intervention program for convicted batterers and regular monitoring of attendance and progress in the program by probation agents;
3. Development of standard administrative procedures and minimum certification standards for all four community batterer intervention programs; and
4. Procedures for accepting clients into batterer intervention programs during the pretrial period, including incentives to encourage defendants to choose this alternative.

After submitting proposals to the JOD Project Director, the four non-governmental service providers received funds from the JOD Initiative to implement these enhancements.

Sojourner Truth House proposed to hire a domestic violence hotline liaison to work between the hotline staff and Sojourner's advocates to better serve victims who call the hotline and need follow-up services. In addition, staff and resources were added to expand their batterer intervention program by creating more Spanish-speaking sessions, a group for women batterers, and an additional location for sessions.

Asha Family Services proposed to add a victim services manager who will coordinate all advocate staff, organize staff training, and oversee data reporting for JOD, and to double the number of clients in batterer intervention groups by hiring part-time staff for facilitating additional sessions.

The Task Force on Family Violence proposed to expand their legal emergency assistance project and their program to assist victims in obtaining restraining orders by hiring additional staff and offering services on evenings, weekends, and at offsite (non-courthouse) locations. They also proposed to expand their batterer intervention program by adding three additional groups to double their capacity to serve batterers, offer gender-specific groups, and bilingual programming.

⁴ It is hoped that greater victim support through the Domestic Violence Crisis Response Unit will lead to increased victim involvement in the court case which will lead to fewer dismissals and greater offender accountability.

Milwaukee Women's Center proposed to hire a case manager to serve older abused women and expand services for these victims, add an evening victims support group, and expand services for batterers by adding groups for African-American men and women offenders.

Primary staff include the executive directors of each of the four community service providers, additional staff for these agencies hired for JOD, and six positions in the Domestic Violence Crisis Response Unit.

JOD Implementation Progress

The Domestic Violence Crisis Response Unit became operational in September 2000 as a pilot program operating in police districts 2 and 3. The advocates working in this unit were able to make contact with many victims shortly after the police responded. As a result of this immediate, on-scene contact, the unit's advocates felt that the victim had a greater understanding of the court process and were more willing to participate in the prosecution of the case. However, as of January 2001, the on-scene component of the response was suspended pending discussions with the police department about safety concerns and police escorts for advocates. The Domestic Violence Crisis Response Unit continues to contact victims by telephone and make referrals for services as needed.

The four community service providers have implemented their plans as proposed for enhancing victim services and expanding batterer intervention capacity. However, how these changes have expanded services for victims has not yet been documented.

Since the beginning of the grant in May 2000 the batterer intervention providers have noticed a sharp increase in the referrals to batterer intervention and a higher percentage of these referrals are appearing for intake and initial sessions. For two of the largest programs (Domestic Abuse Intervention and Batterers Anonymous) during the eight-month period since probation reviews were initiated, referrals have increased from 805 (one year ago) to 1,105. And the percentage appearing for the intake session has increased from 49 to 61 percent. One of the batterer intervention providers indicated that their completion rate has increased from about 50 percent to over 70 percent since the probation status hearings began last May. As mentioned earlier, there is also much greater communication between probation officers and the batterer intervention programs.

JOD Implementation Timeline

October 1999	Milwaukee received JOD award
May 2000	Domestic Violence Judges (3) began post-conviction review hearings; new probation procedures began
August 2000	JOD Implementation Kick-off Meeting
September 2000	Official beginning of JOD <ul style="list-style-type: none">• Domestic Violence Commissioner's court began;• Restructuring of other 3 courts; and• Initiation of the Domestic Violence Crisis Response Unit
March 2001	Initiation of pre-trial monitoring
July 2001	New deferred prosecution agreement in place

Washtenaw County, MI

Washtenaw County is located in southeastern Michigan and is home to the University of Michigan in Ann Arbor and Eastern Michigan University in Ypsilanti. The 2001 population estimate is 318,805 people and 127,549 households. The county is comprised of 83 percent Caucasian, 11.2 percent African American, 4.1 percent Asian/Asian American, 2 percent Hispanic, and .04 percent Native American. It is estimated that 7.5 percent of the population is above the age of 65 and 21.6 percent is under the age of 18. The county is an urban and semi-rural mix. A third of the people live within the City of Ann Arbor, a third live in three incorporated cities (Milan, Saline, and Ypsilanti City) and two heavily populated townships (Pittsfield and Ypsilanti Township), and a third live in semi-rural farmland.

In 1974, work to prevent domestic violence (which includes spouse, partner, and dating violence) began with the advent of the Domestic Violence Project, Inc./Safe House, a non-profit agency providing services, including emergency shelter, to survivors of domestic violence and their children. In the 1980s, the county police agencies became the first in Michigan to adopt mandatory and pro-arrest policies and took the lead in establishing this protocol statewide. Washtenaw County also initiated statewide marital rape (1987) and anti-stalking legislation (1994). In 1992, the county passed the only property tax millage in the country dedicated to the construction and maintenance of a new shelter for survivors of domestic violence and their children. The \$3.2 million raised through property taxes built a new facility including a fifty-bed shelter, children's center, education center and offices for the Domestic Violence Project, Inc./Safe House. The STOP (Services, Training, Officers, Prosecutors) Technical Assistance Office has chosen Washtenaw County as one to highlight so that other programs in the country may learn from their work. In 1998, due to the solid foundation of community commitment to the prevention of domestic violence, Washtenaw County received an award under the federal Grant to Encourage Arrest Policies and Protection Orders Program.

Partner Agency Profiles Prior to Implementation of JOD

Washtenaw County's approach to JOD involves collaboration between multiple governmental and non-governmental agencies. Specifically, the Washtenaw County Prosecuting Attorney's Office, District Courts 14A1-4, 14B, and 15th, the Washtenaw County Sheriff's Department, Ann Arbor Police Department, Pittsfield Township Police Department, Ypsilanti Police Department, the Public Defender's Office, members of the defense bar, Safe House, and Alternatives to Domestic Aggression are all actively involved in shaping JOD policies. The sections below describe the operations of each of these agencies prior to the implementation of the Judicial Oversight Demonstration Initiative.

The District Courts

Description

The Washtenaw County court system is comprised of three separate court districts, 14A, 14B, and 15. The 14A District Court is funded through Washtenaw County and serves the entire county except for the City of Ann Arbor and Ypsilanti Township. The 14A District is comprised of four courts, 14A-1, 14A-2, 14A-3, and 14A-4. District Court 14A-1 serves Salem, Superior, Pittsfield, and Augusta Townships. District Court 14A-2 serves Ypsilanti City. District Court 14A-3 serves Lyndon, Dexter, Webster, Northfield, Sylvan, Lima, Scio, Sharon, Freedom, Manchester, and Bridgewater townships and 14A-4, which is a part-time court, serves Lodi, Saline, and York Townships.

District 14B separated from the 14th District in January 1985 after citizens of Ypsilanti Township voted to have their own District Court. Ypsilanti Township is the second largest Township in Washtenaw County and is second to Ann Arbor in both population and domestic violence cases, comprising approximately 35 percent of all domestic violence cases in the county. There are several characteristics distinguishing this court from the other District Courts. First, the township attorney, rather than the Washtenaw County Prosecuting Attorney, prosecutes all first offense domestic violence cases. This is significant since the Township Attorney is far more likely to offer deferred sentences in first offense domestic violence cases whereas the Washtenaw County Prosecutor's Office, which prosecutes domestic violence cases in the remaining districts, does so rarely. Second, post-conviction review hearings often do not occur until the end of the first year in 14B, rather than between 30 to 90 days as in the other District Courts.

The 15th District Court is funded by and serves the City of Ann Arbor. Three judges preside in 15th District. One judge hears civil cases and most personal protection orders for all of Washtenaw County, while the other two judges preside over criminal matters. In 1998, District Court 15 received an award from the Grants to Encourage Arrest Policies and Enforcement of Protection Orders Program and at that time established post-conviction review hearings and a dedicated domestic violence probation agent. This courthouse has a metal detector which people must pass through. However, the courtrooms for the other district courts, clerks' offices, magistrates, and juvenile court, located outside the downtown county courthouse, are not screened unless metal detector wands are specifically requested for a particular hearing.

Number of Domestic Violence Cases Filed in Washtenaw County District Courts

	14A1	14A2	14A3	14A4	14B County	14B Township	15th	Total
1998	158	194	69	22	353	None ⁵	57	855
1999	150	188	96	37	263	61	113	908
2000	179	133	106	15	159	239	140	971

Average Number of Days to Disposition (from arrest to sentencing) – Year 2000

	14A1	14A2	14A3	14A4	15	Total
Felony	75	65	44	14	48	61
Misdemeanor	56	73	51	35	52	55
Total	58	72	50	34	51	56

⁵ As of October 1, 1999 Township Attorneys began prosecuting domestic violence cases under a local ordinance. Prior to this, they were prosecuted by the county.

Domestic Violence Training for Judges Prior to JOD

The Michigan Judicial Institute provides the only mandatory domestic violence education for judges as part of its new judges education program. All other training is voluntary yet many local judges attend domestic violence trainings. The Michigan Judicial Institute has a major contract with the State for STOP (Services, Training, Officers, Prosecutors) grant funding to provide training to judges on domestic violence and sexual assault. This encompasses orientation to the new Domestic Violence Bench Book written for judges in Michigan.

In 1998 – 1999 Safe House provided six hours of domestic violence training to the district court judges primarily responsible for Personal Protection Orders issuance and enforcement. In 1997, a representative of the Michigan Coalition Against Domestic and Sexual Violence met with all seven of the district court judges in the county to provide a training on domestic violence and to answer specific questions posed by judges.

Relationship with Other Agencies

With the exception of the 15th District Court, the Courts' relationships with the batterer intervention programs were primarily through the probation officer. Judges ordered offenders to intervention programs but the responsibility rested on Washtenaw County Probation to make a specific referral and to monitor defendants' progress. Under the Grants to Encourage Arrest Policies and Enforcement of Protection Orders Program funding, increased communication occurred between the 15th District Court, its probation department, and Alternatives to Domestic Aggression, the largest batterer intervention program in the county. Representatives from these agencies began meeting on a monthly basis for coordination purposes and the Chief Judge and her probation department agreed to serve on the Alternatives to Domestic Aggression advisory council.

The courts had and continue to have a respectful and productive working relationship with Safe House which regularly has advocates present in the courtrooms on days that courts are handling domestic violence cases. Judges often refer victims to Safe House, especially if a victim is requesting that a Personal Protection Order be lifted or request an amendment to pre-trial release conditions. Additionally, the judiciary will at times seek information and assistance from the advocates.

Washtenaw County Prosecutor's Office

Description

In 1998, 11 police agencies filed approximately 1600 domestic violence cases for potential prosecution by the Washtenaw County Prosecutor's Office in Washtenaw County's 14A, 14B and 15th District Courts.⁶ Approximately 900 (59 percent) cases were authorized for prosecution. Since 1998, there has been a small but steady decline in the number of domestic violence cases filed by law enforcement.

Charging Rate for 1998 and 1999

Police Agency	1998					1999				
	Warrant Requests	Charged	Denied	PVNA^v	% Charged	Warrant Requests	Charged	Denied	PVNA^v	% Charged
Ann Arbor	86	56	18	12	75.7%	139	106	30	3	77.9%
Chelsea	7	4	2	1	66.7%	4	4	0	0	100.0%
EMU	3	2	1	0	66.7%	2	0	2	0	0.0%
Michigan St. Police	50	33	15	2	68.8%	43	25	17	1	59.5%
Milan	1	1	0	0	100.0%	3	1	2	0	33.3%
Northfield Township	48	17	31	0	35.4%	47	25	22	0	53.2%
Pittsfield Township	148	88	58	2	60.3%	124	71	43	10	62.3%
Saline	51	15	34	2	30.6%	33	8	24	1	25.0%
U of M Public Safety	11	8	2	1	80.0%	18	10	8	0	55.6%
Washtenaw Co. Sheriff	864	478	365	21	56.7%	762	422	285	55	59.7%
Ypsilanti (city)	312	198	107	7	64.9%	277	188	75	14	71.5%
Total	1581	900	633	48	58.7%	1452	860	508	84	62.9%

^v Police visit, no action.

It is the policy of the Washtenaw County Prosecutor's Office not to consent to pre-trial diversion on any domestic violence cases. The State of Michigan also has a deferred sentence option for first-time convictions of domestic violence. The statute requires that the prosecution consent to the deferral; however, Washtenaw County Prosecutor's Office strongly discourages deferred sentencing on domestic violence cases. Because first time domestic violence misdemeanor offenders are prosecuted by the Township Attorney and not the Washtenaw County Prosecutor's Office, 14B cases are much more likely to receive a deferred sentence. If charges are issued and the defendant is in custody, he appears before a magistrate or judge, usually the same day. If the defendant is not on the scene, and hence not in custody, a warrant is issued and a letter is sent requesting they call the court to schedule an appearance. The Washtenaw County Sheriff's Department makes recommendations to the Court for conditions of release. The remaining ten law enforcement agencies are also required to fill out recommendations for bond conditions but it is unclear if this is occurring consistently. Due to staffing limitations, the Washtenaw County Prosecutor's Office did not vertically prosecute domestic violence

⁶ This number includes cases from Ypsilanti Township as well. However, on October 1, 1999, there was a change in state policy governing home rule that allowed for the addition of a local ordinance with a maximum penalty of 93 days on a misdemeanor. At this time, Ypsilanti Township (14B) passed a local domestic violence ordinance utilizing this penalty and resumed the prosecution of domestic violence cases by Township attorneys. Under this ordinance, arrests and convictions are reported to Central Records.

cases except those cases handled in 15th District Court under the Grants to Encourage Arrest Policies and Enforcement of Protection Orders Program. All seventeen assistant prosecutors assigned criminal trial responsibilities handled domestic violence cases.

In domestic violence cases that were both charged and reached disposition in 1998, 14A and 15th District Courts dismissed approximately 56 percent of these cases on the day of trial due to witnesses failing to appear. Conversely, prosecutors convicted approximately 80 percent of defendants whose domestic violence cases did not have witness problems. The Prosecutor's Office convicted approximately 50 percent of defendants whose domestic violence cases went to trial. Overall, 36 percent of domestic violence defendants whose cases were charged and reached disposition in 1998 were convicted of domestic violence.

Relationship with Other Agencies

There has been a longstanding, respectful relationship between the Washtenaw County Prosecutor's Office and Safe House. Prior to the Grants to Encourage Arrest Policies and Enforcement of Protection Orders Program, the relationship was more informal but the grant sparked a more formal, on-going relationship between the two agencies concerning victim safety and well being.

Additionally, the Prosecutor's Office has had an exemplary relationship for many years with both the District Courts and the 11 law enforcement agencies operating in the county.

Law Enforcement

Description

There are 11 separate law enforcement agencies operating in Washtenaw County. They include Ann Arbor Police Department,⁷ Chelsea Police Department, Eastern Michigan University Police Department, Milan Police Department, Michigan State Police, Northfield Township Police Department, Pittsfield Township Department of Public Safety, Saline Police Department, University of Michigan Department of Public Safety, Washtenaw County Sheriff's Department, and Ypsilanti Police Department. Police countywide responded to 256,672 incidents of varying nature in 1998. Of these, 2,150 calls were specifically domestic violence cases. That number, however, is subject to increase as investigations may determine a domestic violence incident in lieu of family trouble, etc. Nearly 2 percent of calls for service countywide were specifically domestic violence related.

Since 1979, the Washtenaw County Sheriff's Department has handled the largest percentage of domestic violence arrests in the county. In 1999, the sheriff's department responded to 1,179 family trouble⁸ calls out of the approximately 2,300 calls received from law enforcement agencies in the county. The sheriff's department has had a "preferred arrest policy" in place since 1990, meaning that if probable cause exists and the deputy fails to arrest, s/he must provide documentation for why. The sheriff's department was involved in the 1998 Grants to Encourage Arrest Policies and Enforcement of Protection Orders Program, is recognized for their model policies on domestic violence, and assisted in writing the domestic violence statute adopted by the State of Michigan in 1994 and 1998, which is the current state model policy for law enforcement's response to domestic violence.

There is a Domestic Violence Unit within the Ann Arbor Police Department and the sheriff's department. The Ann Arbor Police Department's Domestic Violence Unit consists of an assigned detective handling all domestic violence warrant authorization processes and any follow-up investigation necessary to prosecute the case. The unit also employs a community service assistant and a civilian employee to assist the sworn officer assigned exclusively to domestic violence cases. In the sheriff's department, a sergeant has been assigned to review domestic violence incident reports for accuracy and completeness. Although the shift supervisor reviews all reports at the end of the shift, the Domestic Violence Unit focuses entirely on domestic violence cases and provides a more thorough review of domestic violence incident reports. Incomplete incident reports are returned to the officer for correction. Additionally, the unit collects and compiles statistics on domestic violence, conducts officer training in the arena of domestic violence, and serves as liaison with other agencies in regards to domestic violence cases.

Relationship with other Agencies

The police and prosecution have an exemplary relationship in Washtenaw County, evidenced by the multiple collaborative projects and tasks implemented in the county. Officers often provide information to the court at arraignments, civil protection order hearings, trials, and sentencings. Police and prosecutors collaborate on domestic violence case investigations.

Law enforcement's relationship with Safe House varies by the police department. For instance, the Ann Arbor Police Department implemented in 1988 a mandatory arrest policy in all probable cause domestic violence cases and began calling Safe House for all domestic violence calls. Additionally, the department housed its domestic violence detective and civilian assistant at Safe House, thereby ensuring active collaboration between victim advocates and police. However, due to Safe House's need for the space, the police department's domestic violence personnel were moved back downtown in June 2001. Washtenaw County Sheriff's Department, responding to cases in Ypsilanti Township in 1988, voluntarily went to a pro-arrest policy and started paging Safe House. Around 1990, the sheriff's department initiated a pro-arrest policy in all probable cause domestic violence cases in the rest of the county. As for the remaining 10 law enforcement agencies, each department has their own policy of if and when they will call Safe House, but the practice of most law enforcement officers is that they call Safe House when there is a domestic violence incident. Currently, all but two or three of the 11 police departments formally call Safe House. Additionally, Safe House provides a six-hour domestic violence training to most of the law enforcement agencies in the county thereby providing additional opportunities to build relationships.

⁷ Mandatory arrest policy since late 1985.

⁸ Family trouble calls may include domestic violence calls but are not limited to intimate partner violence calls.

Washtenaw County Probation

Description

Misdemeanant probationers in Washtenaw County are supervised post adjudication by the probation departments for each of the district courts. There is no pre-trial supervision of those charged in misdemeanor domestic violence cases in the county although the 15th District Court requires routine drug screens pre-trial in cases where such substances were involved at the time of the incident.

Prior to JOD, for misdemeanor cases, a centralized probation department did not exist. Rather, each of the three District Courts was responsible for hiring their own probation staff. The 14A District Court has three full-time probation agents and one part-time agent. Each agent works specifically for one judge from that District. The funding unit for 14A probation is Washtenaw County and caseloads average between 250-300 cases and cover all misdemeanor charges.

The 14B District Court has two full-time probation agents, funded through the Township of Ypsilanti; they supervise a caseload of approximately 300 probationers per agent. This Court only has one judge and both probation officers work specifically for that judge.

The 15th District Court has five probation agents plus one supervisor and oversees a caseload of between 175–200 probationers per agent. Agents in this Court report to a probation supervisor. The funding unit for 15th District Court Probation is the City of Ann Arbor. In 1998, the county received a grant through the Department of Justice's Grants to Encourage Arrest Policies and Enforcement of Protection Orders Program. Although the Supervisor of this unit oversaw all domestic violence defendants in addition to his other duties, this grant established more intensive monitoring of domestic violence defendants. For instance, a dedicated probation officer in the 15th District Court was established to monitor all domestic violence defendants and domestic violence probationers were mandated to three Review Hearings within their first 90 days of probation. Furthermore, the Court initiated routine drug and alcohol screens of all domestic violence defendants when such substances were involved in the incident and victim input was elicited and incorporated by the probation officer throughout the probation process.

For the most part, Judges rely upon agents to make recommendations for probation violations. However, given the enormous caseloads and the limitations placed on the agent, recommendations were often based on incomplete information. For example, large caseloads meant that agents only met with probationers once a month and often the contact consisted of a telephone call rather than face to face contact. Agency regulations such as those prohibiting agents from conducting business outside of the office meant that home visits of probationers could not be conducted. This limitation also meant that victim interviews could only be conducted over the phone or the victim had to be burdened to come to the probation office. Consequently, pre-sentence reports rarely included victim comments. The enormous caseloads coupled with limitations placed on agents resulted in an overall lack of intensive monitoring of probationers thereby making it much more difficult to detect violations.

In addition to the lack of intensive monitoring, there was little, if any, training for either the judges or the probation agents on the dynamics of domestic violence, lethality factors, or interviewing techniques. Probation agents often referred probationers to batterer intervention programs that did not meet state recommended standards and the majority of the batterer intervention programs reported offender progress to the probation agent at best, on a monthly basis or only after the offender failed out of the program.

Relationship with Other Agencies

Each of the probation officers has a strong working relationship with their respective judges. Additionally, due to the Grants to Encourage Arrest Policies and Enforcement of Protection Orders Program, the dedicated domestic violence probation officer in 15th District developed a strong, collaborative relationship with one of the batterer intervention programs.

Victim Services – Safe House

Description

Safe House is the private, non-profit, non-governmental victim advocacy program in Washtenaw County. Safe House services include: 1) a 24-hour crisis line, staffed 365 days a year and includes a telecommunications device for the deaf and 24-hour interpretation into 140 languages, 2) a 50-bed shelter, which includes counseling, advocacy, information, transportation, and on-site health care; 3) non-residential counseling; 4) legal advocacy and accompaniment, including assistance in obtaining civil protection orders; 5) 24 hour on-call response for police and health care settings; 6) general and specialized support groups; 7) children's support groups; 8) post-residential services through the Families First program; and 9) intensive support, material assistance, and intervention with survivors through the autonomy program.

Relationship with Other Agencies

Since its inception, Safe House has established strong working relationships within the community, especially with law enforcement. Safe House notes that all but two or three of the 11 law enforcement agencies call Safe House each time they respond to a domestic violence call. Safe House diligently works to include all law enforcement officers in the trainings they provide and recognizes exemplary officers in domestic violence cases by writing their Captains letters of commendation. Additionally, Safe House and one of the batterer intervention programs have a long history of working, consulting, and collaborating on specific cases and community related issues. Finally, there is a longstanding relationship between Safe House and the hospitals and clinics providing emergency services to victims.

Batterer Intervention Programs

Description

There are three batterer intervention programs which follow state-recommended standards for batterer intervention programs, and to which the Domestic Violence Probation Unit has agreed to send their domestic violence probationers. They are Alternatives to Domestic Aggression; Taking Responsibility to End Domestic Aggression; and Education, Training, and Research Services. Alternatives to Domestic Aggression began in 1986 and is a program that specializes in working with men to stop their use of abuse or battering. Alternatives to Domestic Aggression, offered through Catholic Social Services of Washtenaw County, is generally a 52-week program, although 26- and 64-week programs are also available. Alternatives to Domestic Aggression's program is composed of five groups: 1) Orientation Group – men are introduced to the policies, procedures and goals of the program; 2) Discovery Group – men answer the question, “Do I have a reason to be in this program?” Men see their own behavior in others and learn from those who have been working for longer periods of time at making personal changes. Once the men conclude they do have a reason to be in the program, they move to the next group; 3) Foundations of Battering Tactics Group – men learn the “foundations” of the teaching in the Battering Tactics Group, which includes learning the “Alternatives to Domestic Aggression Choice Model”, the Power and Control Wheel, the use of the Alternatives to Domestic Aggression's PAUSE (Preventing Abusive and Unaccountable Self-indulgence Everytime), and the use of the Alternatives to Domestic Aggression's Accountability Plan; 4) Battering Tactics Group – men learn to identify, label, and acknowledge their battering behaviors; and 5) Option Building Group – men practice accountable interpersonal skills, which they will use at all times instead of selectively using them.

Taking Responsibility to End Domestic Aggression's program is a 36-week program utilizing a group psychotherapy approach that takes advantage of the normative influence of the group. This means that once a group is established, group members will tend to conform to the standards, values, and norms, which are held by the group as a whole. As the group inducts new members, their thinking, feelings, and behavior will tend to change in the direction of group norms. These are voluntary changes that occur because of our natural human tendency to want to be accepted by a group. These kinds of changes can occur in any group but the change process is more efficient and powerful when there is a trained group leader. The content of each meeting is determined by the experiences of the group members. Participants volunteer stories about their lives or individuals are selected and asked to describe some recent or past experience. In response, group members offer support, advice, or a description of another experience. The group leader then frames these responses as alternative ways of thinking, feeling, or acting.

Education, Training and Research Services' program has been serving Michigan Courts since 1981 and the program is designed to provide comprehensive education and skills while insuring accountability of battering behavior. The goal of this program is to provide assistance and intervention as the batterer enters the process of becoming non-abusive. Prior to JOD, the program offered weekend, 12 week and 26 week programs. They have recently expanded to include a 44-week program as well as programming for women.

Relationship with Other Agencies

Alternatives to Domestic Aggression's program has a history of established relationships with the Probation agents and courts in the county. The program established relationships with probation officers by providing them monthly faxes of the attendance status of probationers referred to Alternatives to Domestic Aggression. With the Grants to Encourage Arrest Policies and Enforcement of Protection Orders Program, Alternatives to Domestic Aggression developed a strong collaboration with the probation agent from the 15th District Court domestic violence probation officer. In this Court, the agent was provided with weekly attendance reports and attended, along with Safe House advocates, monthly meetings set up by the probation agent.

Office of the Washtenaw County Public Defender

The Washtenaw County Office of the Public Defender represents indigent felony clients in all of the District Courts and misdemeanor indigent clients from District 14A. Model Cities represents indigent misdemeanor clients in 15th District and a private attorney represents indigent misdemeanor clients in 14B. However, the Public Defender's Office handles sentencing of cases originally charged as felony but reduced to misdemeanors in these two courts. Overall, the Public Defender's Office represents approximately 80 percent of the indigent criminal and juvenile cases and 50 percent of the misdemeanor cases in Washtenaw County.

The total number of clients represented is not known since the Public Defender's Office tracks statistics by measuring the actual work performed on cases charged, not the number of individual clients. Therefore, the Office represented approximately 7,500 case charges/dispositions in 2000. Specifically, the Office of the Public Defender represented 2,146 misdemeanor charges, 2,440 felony charges, and 1,828 juvenile charges. Domestic violence charges have not been separated specifically from other charges. However, recently changes have been made to their database that will allow the Public Defender's office to track cases handled solely through the JOD project with specificity.

The Public Defender's Office data system did not allow for tracking by domestic violence charges in 1999 since such cases were classified generally under assault. In 2000, the Office represented 42 felony-level domestic violence 3rd offense case charges, comprising 1.7 percent of all felony offenses represented by the Office of the Public Defender. However, this number is expected to be much larger since many other felony-level assaultive offenses, such as "Assault with a Dangerous Weapon," can not be separated out as JOD domestic cases due to the limitations of their database. There were 272 misdemeanor domestic violence charges in 2000, comprising approximately 12.6 percent of case charges during 2000. Their data system does not have the capabilities to track for gender.

Relationship with Other Agencies

Both the Chief Public Defender and Prosecutor, while functioning in an adversarial system, have an excellent working relationship. The Public Defender's Office has an ongoing relationship with judges, police agencies, and the private bar, since they all serve on several committees formed to address court unification and personal protection orders. Additionally, their office works closely with Safe House since they have mutual clients. The Public Defender's Office often refers clients to Safe House for counseling and support services and for investigation into "battered spouse syndrome" cases. Safe House provides expert witness testimony on "battered spouse syndrome" and offer testimony in plea negotiations and sentencings on behalf of the Public Defender.

Washtenaw County JOD Initiative

As a grantee of the Judicial Oversight Demonstration Initiative, Washtenaw County has received \$1,997,383 for the period of 10/01/99 through 3/31/01. The grant supports the site evaluation coordinator, the Domestic Violence Unit's Prosecution Team (i.e., five prosecuting attorneys, one full-time support staff, two victim/witness specialists, and one domestic violence investigator), the Domestic Violence Unit's Probation Team (i.e., four District Court probation officers, a District Court probation supervisor, and one full-time support staff), the Safe House team (i.e., 1/3 of the legal advocacy Director's time, two legal advocates, a 1/2 time follow-up coordinator, two autonomy advocates, and 1/2 time support staff), a Washtenaw County Sheriff Department sergeant, an Ann Arbor Police Department community service assistant, a domestic violence coordinator for the Ypsilanti Police Department, the Alternatives to Domestic Aggression's Jail Program (a twice a week class preparing for the full program upon release from the jail), approved travel, technical assistance, and administrative costs.

Goals of the Washtenaw County Judicial Oversight Initiative

As established in their strategic planning session, Washtenaw County has established the following goals:

1. Create a cultural environment – with core values – that does not tolerate domestic violence in the Washtenaw County community.
2. Batterers will stop their violence and abuse and be held accountable through comprehensive, consistent, and graduated consequences.
3. Maximize safety and promote and respect the autonomy of victims and their children.
4. Educate and motivate the community to make the safety of victims and their children the first priority in decision-making.
5. Develop and implement culturally sensitive practices in working with people affected by domestic violence.
6. Foster communication and coordination between the community and criminal justice system.
7. Ensure substantive and procedural justice for victims and arrestees.
8. Define and implement clear and measurable criteria for success.

Anticipated Outcomes

From these goals, the county anticipates the following outcomes:

1. Overall, Washtenaw County expects more victim input into the criminal justice system process. Victims will receive additional support and assistance around issues of autonomy and restoration.
2. The court process will become quicker and more efficient, thereby resulting in less delay for the sanctions of batterers.
3. Consequences for batterers will be more consistent and will be graduated. More batterers will be charged with second and third degrees and therefore, will receive graduated penalties for repeat offenses, due to enhanced reporting of first convictions.
4. Judges will have more time to listen to and speak with victims in the court.
5. The number of victims receiving subpoenas for court in a timely manner will increase as will the number of victims receiving assistance resolving transportation and child care problems. As a result, Washtenaw County anticipates an increase in the number of victims participating in prosecution thereby resulting in fewer dismissals and more convictions.

6. In the situations where the subpoena or logistics was not the barrier to participation, the number of prosecutions without victim participation will increase. This will also increase convictions.
7. A new process for enforcing no contact orders and bond violation will be instituted resulting in greater enforcement and quicker sanctions for batterers. The victim will receive a copy of bond conditions and the probation contact.
8. As a result of vertical prosecution and new protocols, uniformity in prosecution will increase.
9. Due to designated dockets and additional resources, prosecutors will be present at sentencing. This will result in more victim impact statements, more restitution, and tougher, more consistent sanctions.
10. Pre-trial monitoring of batterers will occur for the first time. Victim input will be solicited rather than waiting for the victim to find probation.
11. There will be more warrantless arrests for probation violations. Victims will receive a copy of the probation contract. A picture of the assailant will be inserted into the file. This will result in easier apprehension of the assailant by the police.
12. Restitution will be ordered routinely by judges.
13. More batterers will be referred to batterer intervention programs that meet state standards.
14. All defendants and all those convicted of domestic violence will be subjected to intensive monitoring. This will result in quicker sanctions, graduated sanctions, and more consistent sanctions.

System Changes

- Centralized Domestic Violence Unit consisting of:
 - Five Dedicated Domestic Violence Prosecutors
 - Two Government Victim Advocates
 - Five Dedicated Domestic Violence Probation Agents and a Dedicated Domestic Violence Probation Supervisor
 - Two Domestic Violence Investigators
- Creation of dedicated domestic violence dockets in all districts courts in the county
- Pre-trial component for defendants, consisting of a review of bond conditions
- Increased focus on offender accountability and monitoring through:
 - Enhancement of bond conditions
 - Post conviction review hearings
 - Increased contact between batterer intervention programs and Probation
- Establishment of specialized autonomy services within Safe House designed to increase the independence of victims of domestic violence.
- Creation and implementation of a batterer intervention program within the county jail for incarcerated offenders (both those held pending trial and those serving sentences).
- Development of community education materials on the grant goals and activities. Presentations were made to more than twenty governmental and civic groups in the first year of operation and Washtenaw County continues to plan additional presentations.
- Development and implementation of training for all grant employees, members of the grant team and interested members of all constituent groups (courts, probation, prosecution, defense bar, victim advocates, batterers intervention specialists, law enforcement).

Communication Enhancements/Partnerships created

Prior to the Grants to Encourage Arrest Policies and Enforcement of Protection Orders Program, there was no regular countywide forum for discussion of major issues involving domestic violence cases. Now the Executive Team meets twice a month. The Executive Team is comprised of the Director of Safe House, the Washtenaw County Prosecutor, the Chief Judge from the 15th District, and the Washtenaw County Sheriff. Additionally, the Operations Manager for the Washtenaw County Prosecutors Office, the 15th District Court Administrator, the JOD Grant Coordinator, and the Site Evaluation Coordinator are ex-officio members who do not have voting privileges but do attend every meeting and provide input when requested. Washtenaw County also developed a Grant Team, comprised of various subcommittees, which meets once a month to develop protocols implementing the objectives of the grant including development of the public education materials, the Weapons Seizure Protocol and the Conditional Pretrial Release Form. The Grant Team consists of representatives from the Ann Arbor Police Department, Alternatives to Domestic Aggression, 14-A, 14B and 15th District Courts, Pittsfield Township Police Department, Probation, Washtenaw County Prosecuting Attorney's Office, Private Defense Bar, Public Defender Office, Safe House, Washtenaw County Sheriff's Office, Ypsilanti Police Department and the Ypsilanti Township Prosecuting Attorney's Office. Many of the grant partners have also invited input from other grant participants in their various selection and hiring processes.

Additionally, in an effort to enhance communication and collaboration between key JOD players, Washtenaw County created the Domestic Violence Unit. This centralized unit, located at 3800 Packard and operational since July 1, 2000, houses the dedicated prosecutors, investigators, probation officers, and governmental victim advocates handling misdemeanor domestic violence cases in the county. As of March 2001, the county prosecutors also handle felony domestic violence cases.

Figure 6 depicts Washtenaw County's case flow and their planned enhancements for their JOD initiative. Figure 7 illustrates the partner agencies involved in Washtenaw County's initiative.

Figure 6.
Washtenaw County: Current Processing of Misdemeanor Domestic Violence Cases, Year 2000

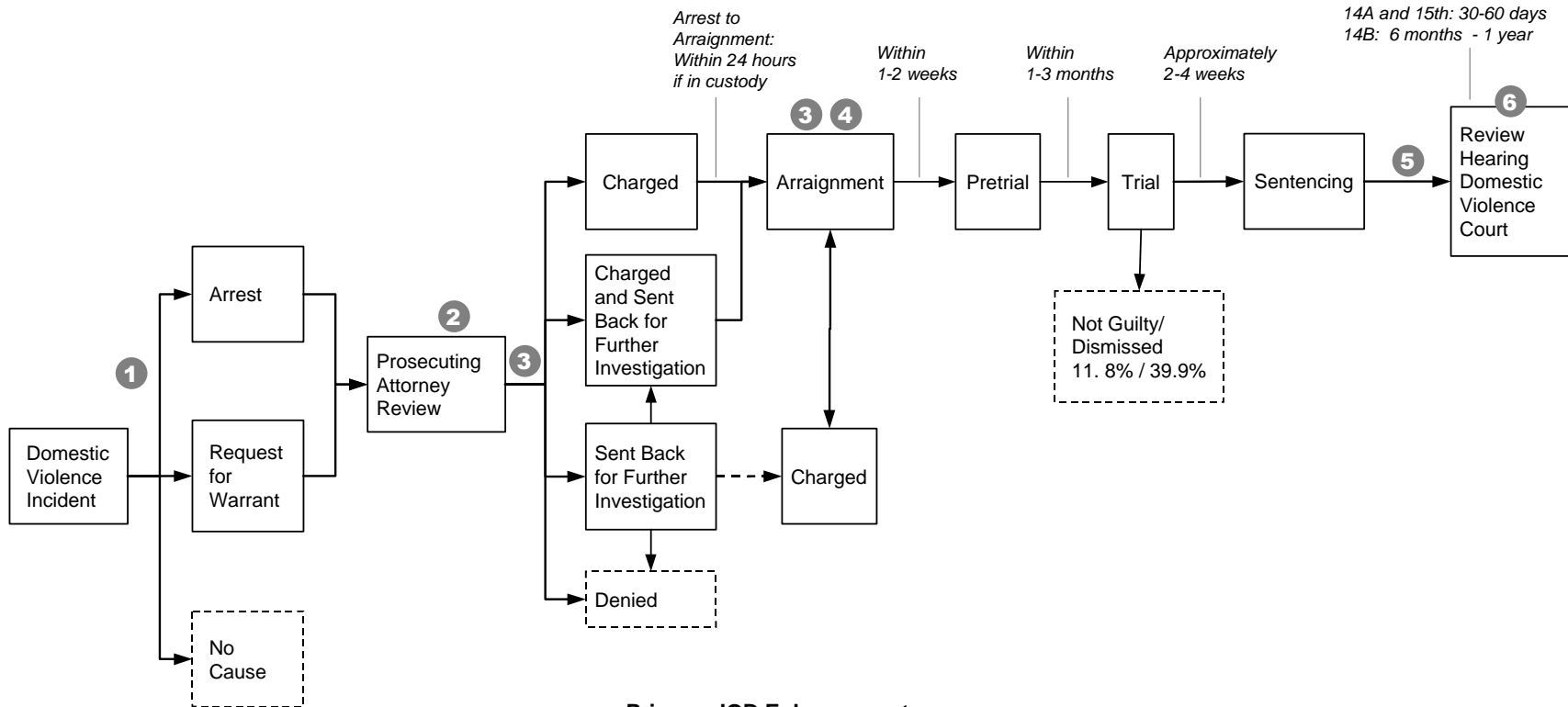

Primary JOD Enhancements

- ① Enhanced officer training in domestic violence
- ② Follow-up/enhanced investigation, if needed, is provided by domestic violence investigators
- ③ Dedicated domestic violence dockets
- ④ Enhanced bond conditions
- ⑤ Domestic Violence Probation Unit providing intensive supervision
- ⑥ Domestic violence judges conduct mandatory probation status review hearings

Figure 7.
Washtenaw County: JOD Network of Partners

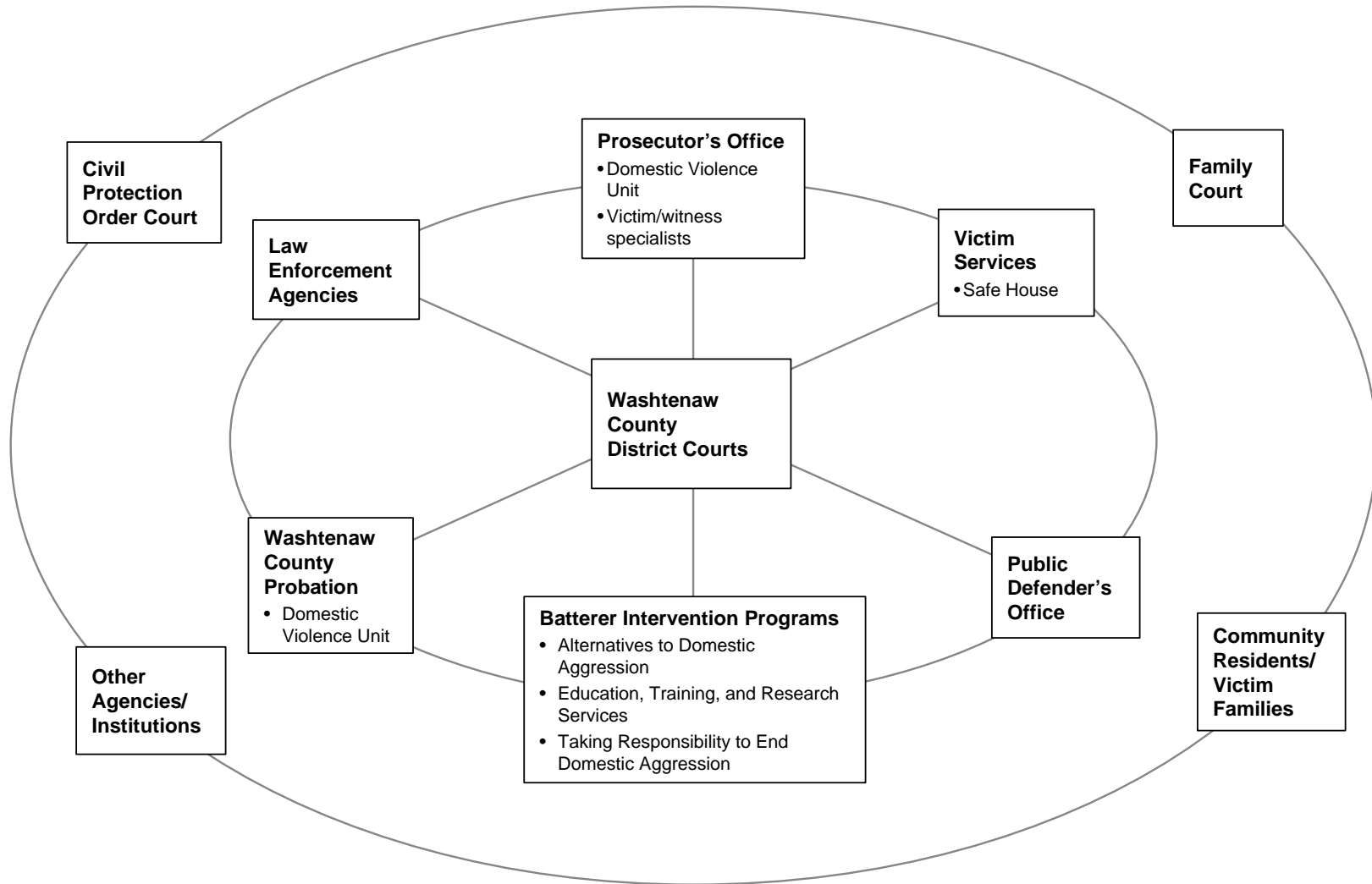

Planned Agency Changes and Initial Implementation

For each of the JOD partner agencies, the planned changes for JOD and the implementation progress since the grant was awarded is discussed. An implementation timeline is presented at the end of this chapter.

District Courts

Planned Changes for JOD⁹ and Implementation Progress

Adoption of Domestic Violence Protocol Among District Court Judges

All of the county's District Court Judges adopted and signed a new domestic violence protocol (Appendix A) and agreed to request that the prosecuting authorities for the municipalities permit all domestic violence prosecutions to be handled through the county Prosecuting Attorney's office. This allows for the charging of cases under state law rather than local ordinances. However, in 14B this is occurring for Domestic Violence 2nd and 3rd offenses only. This is significant in the following ways:

1. The dedicated domestic violence prosecutor, rather than the City Attorney, will handle domestic violence cases in court thereby creating enormous implications for graduated, consistent consequences for batterers.
2. State law requires that police take and maintain fingerprints and report to statewide Central Records the arrest and conviction of domestic batterers.
3. Michigan law now provides for enhanced sentencing of those convicted of domestic violence second or third offenses. Prior to October 1, 1999, local ordinance only allowed for a 90-day or \$500 maximum penalty, and no record of the arrest and conviction was required in Central Records. Accordingly, many batterers convicted in local ordinance prosecution escape detection and prosecution as second or subsequent offenders.

Designated Domestic Violence Dockets. A dedicated domestic violence docket is new due to JOD and is being utilized in all District Courts within the county. Such a docket is expected to increase offender accountability because now all Domestic Violence Unit probation officers will be present in court on domestic violence docket days.

Special Bond Conditions. After hours of negotiations among multiple agencies, Washtenaw County developed a Conditional Bond Release Form (Appendix B) that is reviewed by the judge or magistrate with all defendants released pre-trial and is signed in the presence of the judge or magistrate at arraignment. Copies of the form are then given to the defendant, the Prosecuting Attorney's Office, and Safe House. Additionally, a Victim/Witness Specialist mails a copy to all victims so that they will know when a defendant is breaking a court order. The defendant is then ordered to contact the Probation Domestic Violence Unit within 24 hours to make an appointment with a probation officer who will again review the terms of the bond conditions and ensure that the defendant understands the conditions.

Review Hearings and Violation of Bond Conditions. Prior to JOD, response to bond violations was haphazard and the defendant often denied knowledge of the conditions. The new procedure is attempting to route all notifications of bond violations through the prosecutor's office for review. All violations of bond conditions will be addressed with immediate court review and a system of sanctions. Post conviction review hearings are being held in all District Courts for defendants sentenced to probation. Courts in the 15th and 14A Districts are utilizing review hearings at 30 or 60 days whereas the Court in District 14B is utilizing review hearings at one year.

Subpoenas served. Prior to JOD, the courts were responsible for serving the subpoenas but they were often slow and had much difficulty getting witnesses served. The procedure is to now have prosecutors give the police a list and have the police serve the subpoenas and the courts are noting improvement in the number of witnesses appearing in court.

⁹ 15th District Court received an award under the federal Grants to Encourage Arrest Policies and Enforcement of Protection Orders Program prior to JOD, and as a result, much of the policies to be implemented under JOD were already in place in the 15th District.

Prosecuting Attorney's Office

In the Washtenaw County's Prosecuting Attorney's Office, a number of changes were planned to enhance the strength of charged cases and reduce case dismissals.

Dedicated Domestic Violence Prosecuting Attorneys

Five assistant prosecuting attorneys, two of which handle felony cases, were hired to increase the Office's capacity for prosecuting misdemeanor and felony domestic violence cases.

Vertical Prosecution

Except in the 15th District Court, prior to JOD, there was no vertical prosecution in misdemeanor cases. With the inception of JOD, all misdemeanor domestic violence cases are prosecuted vertically and as of April 2001, all felony domestic violence cases are also prosecuted vertically.

Eligibility Criteria Developed for Deferred Prosecution

The Prosecutor's Office developed an "Eligibility Requirements for Deferral in Domestic Violence Cases" (Appendix C) as part of their JOD protocols.

Enhanced Investigations

Witnesses under subpoena failing to appear and victims recanting are enormous problems when trying to convict domestic violence defendants. Prosecutors saw the need to rely more upon the evidence than on victim testimony and with the initiation of JOD an initiative began to provide officers with more rigorous on-scene investigation training. Additionally, Washtenaw County saw the need for follow-up investigation in many domestic violence cases and hired a domestic violence investigator through the sheriff's department to work closely with the prosecutor to provide such follow-up investigation. Washtenaw County intends to hire another investigator once grant funds are approved.

Prosecution of Felony Domestic Violence Cases by Domestic Violence Unit Prosecuting Attorneys

As of April 2001, the Domestic Violence Unit Prosecuting Attorneys now prosecute all felony domestic violence cases.

Enhanced Victim/Witness Specialist Roles

Prior to JOD, the main responsibility of three Victim/Witness Specialists was to send letters to all victims of violent crime to inform them of their rights. One Specialist was located at the Ann Arbor Courthouse, one at the Service Center, and another at the Juvenile Court. They were mainly used as support staff and their main responsibility involved contacting victims through the mail to inform them of their rights. They did not accompany victims in court nor did they play an active role in encouraging victims to participate in the prosecution process. With the initiation of JOD, their roles changed immensely from that of support towards more of an advocate role. There are currently seven advocates, including the two domestic violence advocates, who work out of the Domestic Violence Unit.

Law Enforcement

Training

The Executive Team, in conjunction with Safe House, has worked to ensure that all law enforcement agencies respond to domestic violence in accordance with the JOD policies and procedures by providing regular training sessions. The training generally consists of: the dynamics of power and control, destruction of myths and stereotypes of the causes of domestic violence (with emphasis on alcohol use, “loss of control” argument); understanding and working with survivors; barriers to survivor safety; helpful law enforcement intervention; effective response to and investigation of domestic violence incidents; and batterer manipulation of police and others. Additionally, the Ann Arbor Police Department has committed itself to training on self-defense injuries in order to reduce the number of victims arrested for domestic violence.

Protocol Developed for Seizure of Weapons

Prior to JOD, no uniform, countywide protocol existed for the seizure, or the return of weapons confiscated in domestic violence arrests. A protocol has recently been developed and is awaiting final implementation (Appendix D).

Committee Convening to Address Police Officers that Batter

The Sheriff and the Prosecutor have agreed to convene a committee to develop a protocol for police officers that batter.

Community Oriented Police Officer

The Pittsfield Township Police Department hired a community-oriented domestic violence police officer as a result of this grant.

Creation of a Domestic Violence Police Report Form

The Washtenaw County Sheriff’s Department created a standardized Domestic Violence Incident Report that is awaiting final implementation (Appendix E). This is being revised with full implementation expected by Fall 2001. Currently, each police agency uses its generic report form for domestic violence cases. The standardized form is to be utilized by all of the county’s 11 law enforcement agencies. The forms will be submitted to an officer of the sheriff’s department for review, then entered into an Access database initiated under the Grants to Encourage Arrest Policies and Enforcement of Protection Orders Program that will be used to track domestic violence statistics.

Probation

Although probation agents still work for a District Court judge, with the inception of JOD, all probation agents supervising misdemeanor domestic violence defendants are housed at the Domestic Violence Unit. This allows the agents to work more closely with the prosecutors. A number of enhancements were planned for JOD. Since the 15th District received an award under the federal Grants to Encourage Arrest Policies and Enforcement of Protection Orders Program, all enhancements listed below, with the exception of pre-trial monitoring and home visits, have been in place for domestic violence probationers in 15th District since 1998.

Judges to Consider Probation Officer's Recommendation

The probation officer will be recommending restitution measures to the judge, including provision/replacement of telephones so that the victim is able to call for help. Additionally, probation officers will make recommendations for appropriate consequences in response to violations.

Pre-Trial Monitoring

As part of JOD, Washtenaw County originally planned to implement a pre-trial monitoring component that would include 1) a review of bond conditions with the defendant, 2) random drug screens, and 3) regular contact with their probation agent. However, the defense bar strongly opposed monitoring of clients who were still presumed innocent. Therefore, Washtenaw County amended its proposed pre-trial monitoring component to include only 1) a reading of the bond conditions and 2) an initial drug test if ordered by the court. If the defendant tests positive at the initial drug test, agents have the discretion to randomly test the defendant throughout their pre-trial period. However, drug tests must be completed in the building next door and are conducted by Washtenaw County Community Corrections staff rather than probation staff. Probation agents are not permitted to conduct follow-up contacts with the defendant during the pretrial period nor are they permitted to discuss the facts of the case. Nonetheless, one of the significant enhancements of the pre-trial monitoring piece is that all pre-trial conditions are now entered into the Law Enforcement Information Network. Consequently, if a defendant is re-arrested, the arresting officer will know the conditions of the client's release.

Home Visits

In March 2001, the Domestic Violence Probation Unit received training in Portable Breath Tests and are in the process of establishing procedures for home visits which will include breathalyzers and urine screens.

Victim Contacts

As part of the pre-sentence report process, all probation agents are attempting to contact the victim for her/his input. Probation agents report that they are able to reach between 75 percent to 95 percent of victims. They can now conduct interviews at the victim's home or wherever it is most convenient for them.

Probation Status Hearings

At least two review hearings now occur within 90 days in 14A and 15th District Courts. In 14B, the first review hearing is generally scheduled between six months and a year from sentencing.

Reduced Caseloads

Prior to dedicated domestic violence probation agents, the high caseloads meant a diminished capacity to detect violations and properly monitor clients. Current caseloads are around 80 to 90 clients and allow for more intensive monitoring of domestic violence probationers.

Office of the Public Defender

Dedicated Domestic Violence Staff Attorney

Prior to JOD, the Office of the Public Defender did not have an attorney dedicated solely to represent clients charged with domestic violence. However, as a result of the grant and the Review Hearings, the Office saw the need for a dedicated domestic violence staff attorney. Since the Public Defender did not receive funds as part of JOD, the need for a dedicated domestic violence attorney placed a financial hardship on this office. Approximately one year into the grant, the county approved and funded a temporary staff attorney to represent domestic violence clients, and the County Commissioner made the position permanent in December 2000.

Training

Training on domestic violence will be developed and provided by the Domestic Violence Project, Inc./Safe House and offered to the County Bar Association and the Public Defender's Office.

Safe House

Autonomy Program

As a result of the grant, Safe House has hired two advocates and developed an Autonomy Program that provides legal advocacy for victims in district court. This enhancement will allow the advocates to work with the victim to identify losses due to the battering – from major issues such as loss of custody of the children to damaged credit history to broken eyeglasses to damaged reputation. The advocates will work with the victim to identify barriers to autonomy (e.g., no car or childcare). The foci would be on both enhancing autonomy and also restoring the victim to the pre-victim status. The advocate will make recommendations to the court as to how the batterer can make restoration to the victim and her children. Restoration may include written or public acknowledgements of abuse and apologies to friends, employers, etc. The advocate will identify community resources for restoration (such as victim's compensation and assistance from religious organizations). One hundred victims would receive these specialized services and would be eligible for an average of \$500 per victim in directed reimbursement. With the addition of these two advocates, Safe House is able to provide more intensive services to more clients and they note that they could not work at this intensity level before the grant.

Dual Arrests

Approximately 10 percent of the intimate partner violence arrests in Washtenaw County result in both partners being arrested. Safe House is concerned with this statistic and has implemented an aggressive training initiative for law enforcement agencies on identifying self-defense wounds.

Batterer Intervention Programs

Alternatives to Domestic Aggression Establishes a Jail Preparation Program

Alternatives to Domestic Aggression developed and implemented a batterer intervention preparation program – called the Jail Intervention Preparation Program – in the county jail, where one-third of inmates are incarcerated for domestic violence-related offenses. The program consists of a 12-session education series designed to prepare men in the jail facility to either enter a long-term batterer intervention program upon release from custody or enter a planned, long-term batterer intervention program within the jail facility.

Alternatives to Domestic Aggression Extended in 15th District

As a result of this grant, District 15 required defendants to attend the Alternatives to Domestic Aggression's batterer intervention program one time per month upon completion of their 52 weeks. Essentially, they extended the 52- week program to 64 weeks.

Offender Monitoring in Batterer Intervention Programs

Prior to this grant, a strong relationship existed between Alternatives to Domestic Aggression and Probation. Alternatives to Domestic Aggression and Education Training Research Services provided probation with monthly progress reports on probationers attending their programs. The other batterer intervention program, Taking Responsibility for Ending Domestic Aggression, did not have such an information exchange system established with probation. Since monitoring of the offender is a crucial component of JOD, Alternatives to Domestic Aggression expanded its weekly progress reporting from 15th to all jurisdictions. Education Training Research Services now provides Probation with weekly attendance reports and monthly progress reports. Taking Responsibility for Ending Domestic Aggression provides a monthly report. All batterer intervention programs provide an immediate report if a probationer fails to show to a group meeting.

JOD Implementation Timeline

October 1999	Washtenaw County received JOD award.
February 2000	JOD Implementation Kick-off Meeting.
April 2000	Creation and implementation of a batterer intervention program within the county jail for incarcerated offenders (both those held pending trial and those serving sentences).
April 2000	Establishment of specialized services within Safe House designed to increase the independence of victims of domestic violence.
August 1, 2000	Creation of a Centralized Domestic Violence Unit for Probation Agents, Prosecuting Attorneys, and Victim/Witness Specialists.
August 1, 2000	Creation of dedicated domestic violence dockets in all district courts in the county.
August 1, 2000	Initiation of post-conviction Review Hearings.
August 1, 2000	Initiation of pre-trial monitoring component consisting of a review of bond conditions and drug testing if ordered by the Judge.
April 2001	The Domestic Violence Unit Prosecuting Attorneys began prosecuting all felony domestic violence cases.