

The author(s) shown below used Federal funds provided by the U.S. Department of Justice and prepared the following final report:

Document Title: Handheld Remote Concealed-Weapons Detector

**Author(s): Franklin Felber, Norbert Wild, Scott Nunan,
Dennis Breuner, and Frank Doft**

Document No.: 178564

Date Received: September 1999

Award Number: 97-LB-VX-K008

This report has not been published by the U.S. Department of Justice. To provide better customer service, NCJRS has made this Federally-funded grant final report available electronically in addition to traditional paper copies.

<p>Opinions or points of view expressed are those of the author(s) and do not necessarily reflect the official position or policies of the U.S. Department of Justice.</p>

178564
C.2

JAYCOR

Handheld Remote Concealed-Weapons Detector

Final Technical Report

J200-99-0032/3031

Franklin Felber, Norbert Wild, Scott Nunan, Dennis Breuner, and Frank Doft

Submitted to:

**National Institute of Justice
Office of Science and Technology
810 7th Street NW
Washington, DC 20531**

Submitted by:

**Jaycor, Inc.
9775 Towne Centre Drive
San Diego, CA 92121**

Under Grant No. 97-LB-VX-K008

**PROPERTY OF
National Criminal Justice Reference Service (NCJRS)
Box 6000
Rockville, MD 20849-6000**

February 1999

ABSTRACT

A handheld, battery-operated prototype of a remote concealed-weapons detector has been built and tested. The concealed-weapons detector will enable law enforcement and security officers to detect metallic and nonmetallic weapons concealed beneath clothing remotely from beyond arm's length to about 20 feet. These detectors may be used to: 1) allow hands-off, stand-off frisking of suspects for metallic and nonmetallic weapons; and 2) search for metallic and nonmetallic weapons on cooperative subjects at courthouse entrances and other monitored security portals.

We have demonstrated that we can image weapons concealed under heavy clothing,^{1, 2} not just detect them, at ranges up to 15 feet using the same ultrasound frequency (40 kHz) used by commercial rangefinders. The concealed-weapons detector operates much as a rangefinder, but at higher peak fluxes and pulse repetition frequencies. The detector alerts the user to concealed weapons audibly and visibly by detecting ultrasound glints above a body/clothing baseline, and by compensating for changing range and attenuation. The detector locates concealed weapons within a 6-inch illuminated spot at 10 feet. The signal processor eliminates any signal from behind the target.

Keywords: Ultrasound, concealed weapons, detector, handheld, remote, nonmetallic

1. INTRODUCTION

We have developed and built several working models of a handheld detector. From beyond arm's reach of a suspect, the detector locates metallic and nonmetallic weapons concealed beneath clothing. The detector works by transmitting narrow ultrasound pulses and detecting the ultrasound glints reflected off hard surfaces beneath clothing.

The reason for developing this detector is to put low-cost, concealed-weapons detectors in the hands of law-enforcement and security officers. The goal is to enable officers to perform remote "pat-downs" and to induce behavior modification. No concealed-weapons detection (CWD) technology can yet claim reliable probability of detection (P_d) of all metallic and nonmetallic weapons concealed under all types of clothing under all conditions. That means that a remote "pat-down" with any concealed-weapons detector can not yet substitute for a hands-on pat-down. But a detector can sometimes alert an officer to potential "hot spots" on a suspect, which might cue the officer to issue a different set of commands. The detector might also provide reasonable grounds for a more intensive search. Just pointing the detector and its bright light at a spot where a weapon is concealed might induce changes in behavior that can alert an experienced officer.³

Although the handheld ultrasound detector has the same fundamental limitation on P_d as all other detectors, it does have certain advantages over other detectors. These advantages may be summarized as:

- Low cost.
- Lightweight.
- Detects metallic and nonmetallic weapons.
- Instantaneous operation at a distance.

The cost of the handheld ultrasound detector is not \$100,000 like soft-x-ray backscatter machines or high-end long-wavelength infrared cameras. The cost is not \$10,000's like passive millimeter-wave or infrared sensors. The cost is not \$1,000's like radar guns or airport-type gates. The cost of a handheld ultrasound detector, in quantity, will be \$100's, like handheld metal-detector wands used at airports.

Not only will the cost be comparable to handheld metal-detector wands, but the size and weight will be too. The first working model weighs 3.3 lb. The second weighs 1.9 lb. We expect the molded prototypes and the first generation of handheld detectors to weigh 1 to 1.5 lb.

The handheld ultrasound detector differs from metal-detector wands, as well as certain other radar-based and magnetic-based CWD technologies, in that it can detect nonmetallic, as well as metallic weapons. Nonmetallic weapons reflect ultrasound glints just as well as metallic weapons do. For an ultrasound detector, the area and reflectivity of glinting surfaces have much more to do with detectability of a weapon than just the material. We first demonstrated this capability of ultrasound to detect nonmetallic weapons by imaging a Lexan knife concealed beneath a wool sweater on a human body at a range of 4 ft.^{1,2}

Some CWD technologies require time to develop or process an image, or require a suspect to walk through a portal or stand next to a machine. The handheld ultrasound detector operates instantaneously at a distance. Some of the same ultrasound technology that enables a blind bat to catch a flying insect is used for real-time CWD at a distance.

2. CONCEPTUAL DESIGN

A handheld ultrasound detector can be built in at least two basic configurations – like a radar gun and like a TV remote control. The first working models were built in the radar-gun configuration shown in Figure 1. Regardless of the configuration, the detectors have certain features in common. Both configurations are monostatic, meaning the same integral unit, comprising one transducer and one reflector, is used for both transmitting and receiving the ultrasound signal. Other important features in common are the aiming light and indicators.

The TV-remote-control configuration has a collapsible dish with no barrel. The collapsible dish is intended to allow the device to be carried on a duty belt while protecting the transducer and aiming light. The radar-gun configuration has a fixed dish and barrel. The fixed barrel is intended to protect the transducer and aiming light at all times, but makes carrying the detector on a duty belt impractical.

Both configurations use a single transducer. The active element of the transducer is a flexural bimorph, comprising a piezoelectric ceramic on a metal plate. The active element is sealed in a waterproof metal case, since the transducer may be exposed to moisture and rain. The peak sensitivity at 40 kHz of about 0.35 mV/ μ bar and peak sound-pressure level of about 100 μ bar at 30 cm and 10 V_{rms} is more than adequate for our purposes with our custom amplifiers and filters. Getting sufficient return signal is not an issue. The amplifier gain must be dialed down considerably to a level at which the typical non-reflective clothing of an unarmed person gives an almost unnoticeable return signal.

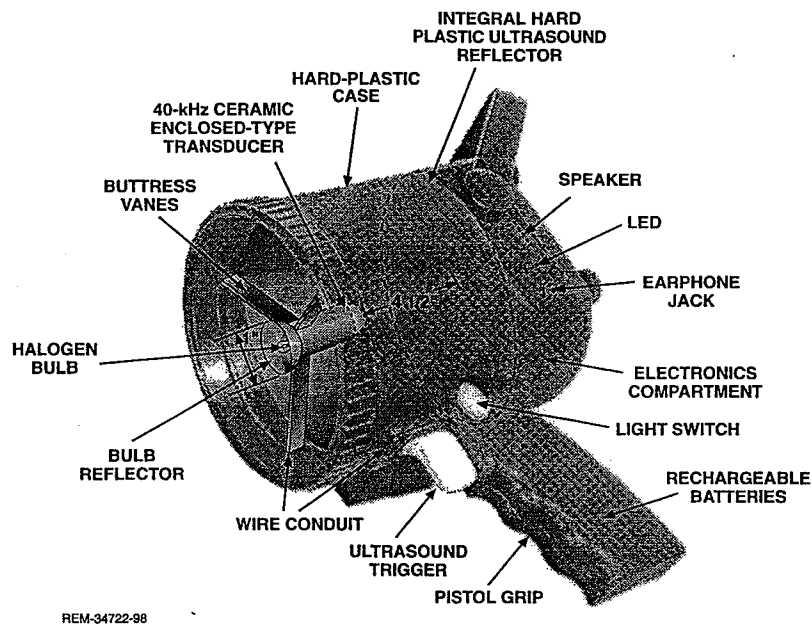

REM-34722-98

Figure 1. Components of handheld ultrasound concealed-weapons detector in radar-gun configuration.

The operating frequency of the ultrasound detector, 40 kHz, was a trade-off between beam directivity and clothing penetration. A higher ultrasound frequency of more than 40 kHz makes a narrower ultrasound beam, but does not penetrate clothing as well. Since a narrower beam is not needed for the present design concept, a higher frequency than 40 kHz is not needed. A lower ultrasound frequency has better clothing penetration, but a wider beam divergence through diffraction. The improved weapon signal from better clothing penetration at lower frequency would be at least partly offset by the increased clothing clutter from a larger area spot on target. The spot area and clothing clutter increase inversely as the square of frequency for frequencies below 40 kHz. Lastly, 40 kHz is a common frequency for air transducers, which are widely available at that frequency.

The beam from the front face of the transducer is wide. The ultrasound beam directivity (full width at -3 -dB points) is about 100° . For that reason, we designed the parabolic reflecting dish with fast ($f^\# = 0.75$ to 0.9) optics. Our original design was a parabolic dish diameter of 6" and a focal length of 4.5". The more recent working models have a 5" dish and 4.5" focal length, and perform about the same as the 6"-dish system.

This geometry makes best use of the dish area by capturing most of the transmitted beam over the full area of the dish. A much bigger or smaller dish than 5" or 6" would result in a bigger spot on target, which is undesirable. A much bigger dish would produce a wider collimated beam, and is undesirable in terms of size and weight. Also, the added gain of a bigger dish is not needed. A much smaller dish would produce a wider diffracted beam.

The effective full-width-at-half-maximum-intensity (FWHM) beam divergence is 2.6° with the 6" dish and 3.0° with the 5" dish. These divergences respectively correspond to about 5.5" to 6.5" spots on a target at 10'. The effective divergence of a beam reflected by a pole in this monostatic system is less than the diffraction-limited divergence of the same beam profiled

directly. The diffraction-limited FWHM beam divergence of a bistatic 6" dish at 40 kHz is 3.3° , compared to the effective divergence of the monostatic system of only 2.6° . That is because sweeping a beam from an aperture across a line reflector, like the vertical pole we used for these measurements, is not equivalent to profiling the beam intensity directly through an aperture. In Section 3, we will show that a vertical pole is a good representation of a concealed handgun in that it gives the same power-law decay of voltage signal vs. range.

We designed the system to operate optimally at a range of about 7' to 12', and designed the system "optics" to probe about a 5" or 6" spot on a person at that range. The "sweet spot" in range is intended to be beyond the reach of a suspect even after a single-step lunge, but close enough to mitigate the glint-angle sensitivity of the detector, described in Sec. 3. The 5" or 6" spot size at that range is optimal for several reasons. The spot size is comparable to the characteristic size of many concealed weapons. If the ultrasound spot were much bigger, then the signal-to-clutter ratio would suffer, as the return signal would include reflections from a larger area of clothing. If the ultrasound spot were much smaller, then adverse consequences would include a larger (non-parabolic) dish, a smaller depth of focus of the detector, and a longer time required to scan a suspect.

Figure 2 shows divergence measurements of a 40-kHz ultrasound beam from a 6" dish, reflected from a vertical pole. Not only is the apparent FWHM divergence of the beam with the monostatic system narrower than that of a directly profiled beam, but the diffraction rings, or side lobes, characteristic of diffraction patterns are suppressed. The result of the monostatic configuration and transmitter and receiver design is an exceptionally clean and narrow beam with a good capability of precisely locating concealed weapons on a body to within inches.

Our human-factors studies have shown that the ability to locate a concealed weapon within inches at distances of about 10' depends not only on having a sufficiently narrow beam, but also on guiding the eye to that spot. With its large barrel, the detector can not be aimed as precisely as, say, a handgun. Aiming accuracy is one of the reasons why all of our working models have aiming lights on the axis of the dish. A second reason is that the bright glare of the light decreases the ability of the suspect to see, particularly at night. A third reason has to do with modifying a person's behavior with a bright light being scanned over his body.

The aiming light is a 6-V halogen lamp, and reflector with about a 1" diameter. It is used by some police on, or with, their handguns, partly to dazzle their targets.⁴ The 5-W aiming light draws many times more power than the ultrasound system. For that reason, the detector has separate switches for the ultrasound and the aiming light. The ultrasound and the aiming light may be optionally used together or alone. The spring-loaded trigger on the pistol grip switches on the ultrasound transmitter, receiver, and audible and visible indicators as long as it is depressed. A separate on-off switch controls the aiming light. We tried reversing the functions of the finger-pressure trigger with the on-off switch on our first working model, but the reversed configuration seemed less desirable from a user's standpoint. We have also considered a two-position trigger, with a half pull turning on the ultrasound and a fully depressed trigger turning on the aiming light. We have not yet implemented a two-position trigger on any working models.

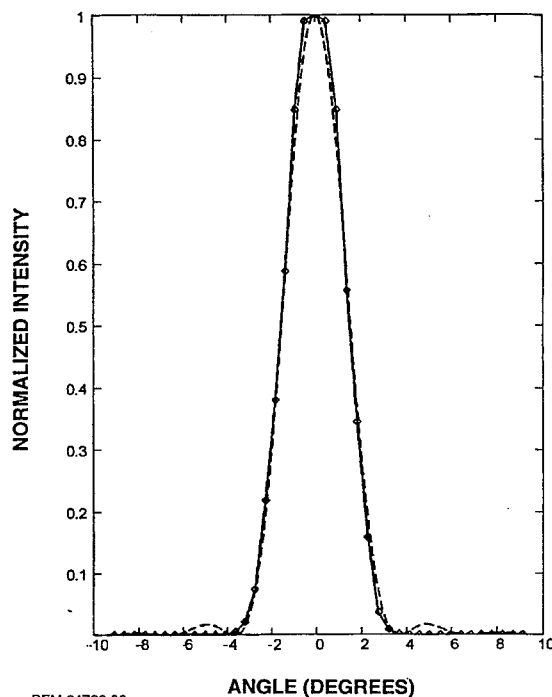

Figure 2. Normalized intensity of ultrasound beam reflected from vertical pole vs. angle of pole off beam axis. Measurements (solid curve and data points) and best-fit diffraction pattern (dashed curve).

The strength of the ultrasound signal returning from a target is indicated audibly and visibly. The audible indicator is a tone that rises in pitch and apparent volume with a stronger return. The visible indicator is a row of five light-emitting diodes (LEDs). Both indicators have a threshold, adjustable on the working models, below which a return signal will not register. The threshold of detection was set such that virtually all signals returned from an unarmed person wearing non-reflective clothing (cloth, woven materials, etc.) were below threshold. Then the gain was adjusted such that the highest audible and visible indicator signals corresponded to a handgun concealed under light clothing. The signal returned from a handgun concealed under light clothing, such as a cotton/polyester shirt, is expected to be the strongest signal that will ever need to be compared to other signals by the user. By this approach, conventional analog circuitry accomplished all the signal processing that was done with the working models. Future models would be expected to include digital signal processing, primarily to address signal-to-clutter issues.

The strongest return signal causes the highest pitch, about 4 kHz, to be emitted by the speaker. Tones of equal loudness sound loudest for humans at about 4 kHz, the frequency at which the ear is most sensitive.⁵ Therefore, the highest pitched tone from the speaker also sounds the loudest. The later working models have an earphone jack as well as a speaker. When the earphone is plugged into the jack, the speaker is disconnected, and the only sound from the audible indicator comes through the earphone. The earphone allows the user, at his own option, to avoid disclosing the results of his search to the suspect. The user may also choose to unplug the earphone from the detector, and allow the suspect to hear the speaker, for purposes of behavior modification. All working models have a volume control for the audible indicator.

The row of five LED lights is mounted on the rear of the detector to be easily visible to the user, and not visible at all to the suspect. One LED is lit as a simple "on" indicator whenever the ultrasound is transmitting. The second LED does not light up until the threshold of weapon detection is exceeded. The gain is adjusted such that detection of a strong ultrasound glint from a handgun concealed under light clothing causes all five LEDs to light up.

The visible and audible indicators working together give more information to the user than either does alone. Of the two, however, the audible indicator is the more sensitive and more revealing. The audible indicator has a continuous scale of gradations of pitch, compared to just a few discrete gradations of the visible indicator. But the few discrete levels of the visible indicator help to objectify and calibrate the audible indicator in the user's mind, and might prove more useful than the audible indicator in court testimony.

The pulse repetition frequency (PRF) of the detector is 10 Hz. The transmitted pulse rings up in about 10 wave periods (0.25 ms), and rings down in about 1 or 2 ms, with a quality factor Q about 50 to 100. The signal processing is done with analog circuitry and standard digital pieceparts. The received pulse is filtered and amplified. An RC circuit filters out the 40 kHz frequency and produces an envelope pulse shape. If the pulse amplitude exceeds a threshold, which is adjustable in the working models, then the signal is processed further to cue the audible and visible indicators. Even if the return signal voltage is far below threshold, however, the first detectable signal returned from each pulse initiates a time gate. Any signal received more than a few ms after the first detectable return from a pulse is ignored. In this way, anyone or anything behind a suspect is gated out of the signal. The gate reopens about 7 ms after the next pulse is transmitted to allow the transducer time to ring down fully. This gate sets the minimum range of the detector at about 3'.

3. TECHNICAL ISSUES

This section discusses some technical issues that were addressed in designing and building the first working models of the handheld ultrasound concealed-weapons detector. In order of most challenging to least challenging, the technical issues include:

- Low signal-to-(clothing)clutter ratio.
- Glint angle sensitivity.
- Voltage attenuation with range.
- Background clutter.
- Transducer mounting sensitivity.

The first two issues in this list have not been fully resolved in the working models, and will benefit from further signal processing and hardware improvements in later versions. The other issues are fully resolved. The first two issues are primarily responsible for shortfalls of the detector in P_d and false-alarm rate. We are not aware of any detector of nonmetallic weapons for which low signal-to-clutter is not an issue. Any detector capable of finding nonmetallic weapons must get some kind of signal from clothing as well. Moreover, for any detector, the signal from the outermost clothing layer is unattenuated by any layers of clothing, unlike the signal from a concealed weapon.

Some features of our ultrasound detector help mitigate the problem of low signal-to-clutter. Keeping the ultrasound spot size smaller than about 6" on target reduces the area over which clothing can reflect. Although most clothing reflects ultrasound poorly, the signal reflected from a large area of clothing can be greater than a small glint from a weapon. The strongest weapon signals are glints reflected from flat facets, like a gun butt or knife handle or blade. Most clothing does not have hard, flat surfaces that reflect ultrasound specularly. Exceptions include some kinds of leather jackets, for example.

Harmless concealed objects that do have hard, flat surfaces, like a pocket calendar or a wallet, can also reflect ultrasound specularly and produce false alarms. Since the detector only detects, and does not image, concealed objects, it is susceptible to such false alarms. The ultrasound imaging capability that we demonstrated with a different device^{1,2} was sacrificed in the handheld detector to achieve low cost, compact size, and lightweight.

Because the ultrasound beam is highly directional, as seen in Figure 2, specular reflections, such as glints from flat weapon facets, can only be seen over a narrow range of angles, of the order of 3°. The detector cannot even see a floor or a wall if aimed more than a few degrees off the normal to the flat surface. Fortunately, most weapons, like handguns, have multiple facets that can be detected. Some, like razor blades or shards of broken window glass, have only one specular reflection angle, and must be detected within about a 3° cone angle. Cylindrical weapons, like some shivs or pens, can be detected at any angle azimuthally, but must be detected within about 3° of the equatorial plane.

This glint angle sensitivity of the ultrasound detector reduces the P_d of the detector because of the chance that the detector will not irradiate a flat facet of a weapon at near normal incidence. Most nearly flat concealed weapons, like handguns or knives, are carried flat against the body. The most productive angle for aiming the detector at each spot, therefore, is normal to the body surface. An effective way to use the detector is to aim it at locations on the body where weapons are likely to be concealed, and then use lateral and vertical motions of the arm to cover a range of angles about the normal while aiming at the same spot.

The range of angles of incidence of the ultrasound beam on a suspect is limited. If only the arm holding the detector is moved, the range of angles of incidence is reduced about inversely as the range to the suspect is increased. For this reason, finding a concealed weapon becomes nearly impractical for the detector beyond about 12', and nearly impossible beyond about 20'. Again, the range limitation is not because of attenuation of the ultrasound with range, but because the range of angles of incidence is limited.

Ultrasound is attenuated with range. The normal divergence of the ultrasound beam spreads much of the reflected pulse energy out beyond the receiver dish. In addition, 40-kHz ultrasound is attenuated by absorption at most about 0.38 dB/ft (1.3 dB/m), depending on humidity.⁶ Without absorption, the ultrasound signal voltage reflected from a large planar surface, such as a wall, would decay as the -1 power of range. Without absorption, the voltage of the ultrasound signal reflected from a small area or a diffuse scatterer would decay as the -2 power of range. (The signal intensity would decay as the voltage squared, or as the -2 and -4 powers of range, for a purely specular reflector and a diffuse scatterer, respectively.)

Figure 3 shows that the signal reflected from a concealed handgun decays with range much more like that from a diffuse scatterer than from a plane specular reflector. Including the effects of absorption, the voltage of the maximum signal reflected from a concealed handgun scales as the -1.9 power of range for ranges from 4 ft to 12 ft. Figure 3 also shows that the voltage of the maximum signal reflected from a cylindrical pole scales about the same as that of a handgun, even at two different gain settings of the detector.

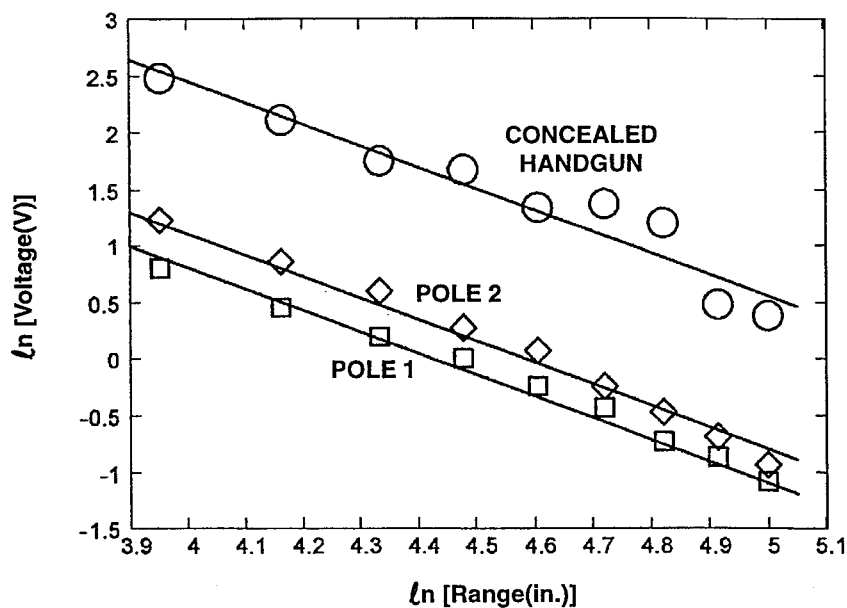

REM-34724-98

Figure 3. Signal voltage (\ln volts) vs. total range (\ln inches) measured (data points) for ultrasound signal reflected from pole at two different gains and from handgun concealed under sweater on body (at gain of Pole 1). All straight lines have slope -1.9 .

Compensating for the decay of signal voltage with range is an essential feature of the ultrasound detector. Without compensation, the false alarm rate would be unacceptably high at close range and the P_d would be unacceptably low at more distant range. The compensation of voltage with range was accomplished with a commercial low-noise, wideband, variable-gain amplifier chip in a custom-designed circuit. Since the signal reflected from a pole scaled the same with range as that of a concealed handgun, we used the pole as a convenient moving target in adjusting the circuit parameters to flatten the voltage response with range.

The flatness of the voltage response with range to within about $\pm 5\%$ was measured by an oscilloscope and confirmed by the audible indicator of the detector. We adjusted the circuit parameters until the pitch of the audible indicator sounded the same with the target pole at all distances between 4' and 12'. The audible indicator of the detector seemed to calibrate the voltage response more sensitively than an oscilloscope, which underscores the importance of the audible indicator to the user of the detector.

Other people or objects behind a suspect may reflect spurious ultrasound signals to the detector. Removing such background clutter from the signal reflected from a suspect is much easier than removing clothing clutter. A simple time gate in the detector essentially selects a 12" to 18"

depth of field over which a signal is accepted, and eliminates all reflections coming from a greater distance. The clock on the time gate starts at the moment the first return signal after a pulse is detected. The gate closes about 2 or 3 ms later, and all other return signals after that pulse are rejected. The time gate reopens about 7 ms after the next pulse is transmitted.

As an example of the kind of routine hardware issues that needed to be addressed in the working models of the ultrasound detectors, we mention the transducer mounting sensitivity. In each working model, the transducer is mounted inside a cylindrical shell suspended over the reflector dish by thin buttress tubes. In the first working models, a tiny setscrew through the cylindrical shell fixes the transducer position inside the shell, so that the face of the transducer remains at the focal point of the dish. We had noticed a difference in the voltage response of different mounted transducers when looking at the same target. At first, we ascribed these differences to normal piece-to-piece variations. Later tests showed that these differences occurred with the same transducer after it was remounted. After one full turn of the setscrew, further tightening of the setscrew against the side of the transducer caused the voltage response to drop by 35% or more. The solution used in subsequent working models was to glue the transducers in place, rather than using setscrews.

4. FIRST WORKING MODELS

Figure 4 shows the first working model of a handheld ultrasound concealed-weapons detector. Figure 5 shows the next four working models, which were all identical in outward appearance. All of the working models have been built in the radar-gun configuration, because we have not yet found a commercially available collapsible dish suitable for the TV-remote-control configuration. The first working model was demonstrated in a videotape⁷ and at a meeting of the California Border Alliance Group (CBAG).⁸ In the videotaped demonstration, the model shown in Figure 4 was aimed at a (nonmetallic) Lexan knife concealed under a heavy sweatshirt worn by a human subject 7' from the detector. The concealed Lexan knife activated the audible and visible indicators. When the knife was removed from under the sweatshirt, the audible and visible indicators showed no response. As the detector was swept over the body of the now unarmed subject, the indicators continued to show no response.

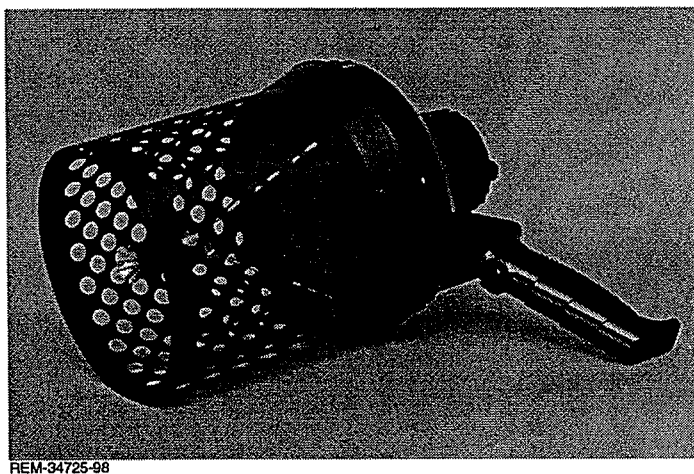

REM-34725-98

Figure 4. First working model of a handheld ultrasound concealed-weapons detector in radar-gun configuration.



Figure 5. Later working models of the handheld ultrasound concealed-weapons detector.

The only intentional lightweight feature of the first working model, which weighs 3.3 lb. (52.5 oz), is the perforations in the aluminum barrel. The weights of the six main components are:

- Reflector dish/transducer/lamp assembly 13.0 oz
- Plastic housing 10.8 oz
- Aluminum barrel 8.5 oz
- Delrin ring (joining barrel and housing) 8.1 oz
- PC board/speaker 6.2 oz
- Batteries 5.9 oz

The first working model, shown in Figure 4, has a 7" barrel and 6" dish. The later working models, shown in Figure 5, have a 5" dish, and weigh 1.9 lb. without the barrel. Molded plastic prototype detectors with 5"-dia. dishes and 5"-dia. barrels are expected to have weights in the range of 1 to 1.5 lb. Weight savings are estimated in parentheses for each change from the first working model:

- Eliminate the delrin ring by making the plastic barrel integral with the housing (8 oz).
- Change barrel and housing from 7" diameter to 5" diameter (6 oz).
- Replace the renboard reflector with a thin plastic dish (5 oz).
- Replace the aluminum barrel with a stiff plastic mesh (4 oz).
- Replace the prototype vector board with a printed circuit card (3 oz).
- Eliminate separate batteries for ultrasound (2 oz).

In the TV-remote-control configuration with a folding dish, the weight of the detector would probably be in the range of 1.25 to 1.5 lb. with the aiming light and about 1 lb. without. The aiming light is recommended, however, for human factors considerations.³

Later versions of working models, shown in Figure 5, have a number of improvements over the first one, shown in Figure 4, including:

- 5"-dia. housing and reflector dish.
- Lightweight barrel and retaining ring.
- Finger-pressure trigger for ultrasound and on-off switch for light.
- Jack for earphone with speaker override.
- Rechargeable batteries.
- Entire circuit operating off the same batteries.
- Glue-mounted transducer.

Lightweight prototype detectors could be fashioned after the later versions of the working models. In the radar-gun configuration, each detector will require three or four molded parts. Made with laser lithography, each mold is good for about 20 copies. The molds are made from three-dimensional engineering designs. PC boards for prototypes could be fabricated from Gerber-file layout drawings.

In conclusion, we have built several working models of a handheld ultrasound concealed-weapons detector. The models can be used now in certain law-enforcement applications involving behavior modification. Future versions that will feature more reliable P_d and lower false-alarm rates will require improvements in the hardware and signal processing.

All concealed-weapons detectors can be used for behavior modification, not just the handheld ultrasound detector. And all present-day detectors must be considered somewhat unreliable. Even tried and tested workhorse systems that can detect only metallic weapons must be considered unreliable with respect to that limitation. Officers charged with responsibility for portal security are not adequately defending civilians from all concealed-weapon threats if their security systems detect only metallic weapons, as most do.

The test for full reliability of a concealed-weapons detector is whether one can have complete confidence in all situations, after using just the detector, that a suspect is unarmed. The use of any present-day detector must be followed at least by a hands-on pat-down to achieve full reliability. In that sense, all present-day detectors are equally inadequate. Of course, to provide reasonable grounds for a search, the detector must be able to detect concealed weapons in some reasonable number of situations, and find no weapons on unarmed persons in some reasonable number of situations. What constitutes a reasonable P_d and a reasonable false-alarm rate has not yet been established. Because of the infinite variety of weapons and clothing and situations, P_d has not even been defined yet. As CWD technology improves, however, performance expectations will rise.

5. ACKNOWLEDGMENTS

The National Institute of Justice sponsored this work under Contract No. 97-LB-VX-K008. The authors gratefully acknowledge helpful discussions with Irv Smietan, David Ferris, and Lt. Sid Heal.

6. REFERENCES

1. F. S. Felber, H. T. Davis III, C. Mallon, and N. C. Wild, "Fusion of Radar and Ultrasound Sensors for Concealed Weapons Detection," in *Signal Processing, Sensor Fusion, and Target Recognition V*, I. Kadar, V. Libby, Eds., Proc. SPIE 2755, 514 - 521 (1996).
2. F. S. Felber, C. Mallon, N. C. Wild, and C. M. Parry, "Ultrasound Sensor for Remote Imaging of Concealed Weapons," in *Command, Control, Communications, and Intelligence Systems for Law Enforcement*, Edward M. Carapezza, Donald Spector, Eds., Proc. SPIE 2938, 110 - 119 (1997).
3. Private communication, Lt. Sid Heal, Los Angeles County Sheriff's Dept.
4. Private communication, Sgt. L. Salcida, armorer for the Los Angeles Police Dept.
5. L. E. Kinsler, A. R. Frey, A. B. Coppens, and J. V. Sanders, Fundamentals of Acoustics, 3rd Ed. (Wiley & Sons, New York, 1982).
6. R. C. Weast, ed., CRC Handbook of Chemistry and Physics, 67th Ed. (CRC Press, Boca Raton, FL, 1986), p. E-46.
7. "Handheld Remote Concealed-Weapons Detector (4:13)," Jaycor videotape, 1998.
8. F. Felber, "Handheld Ultrasound Concealed-Weapons Detector," Jaycor Presentation J200-98-0048/7200-1 to the California Border Alliance Group, San Diego, CA, 22 July 1998.

APPENDIX A.

CATEGORICAL ASSISTANCE PROGRESS REPORT, 7/1/97 TO 12/31/97

Introduction

The Handheld Remote Concealed Weapons Detection (HRCWD) Program began June 1, 1997. As of the end of the reporting period, June 30, 1998, 71.9 percent of the program had been completed. On Feb. 2, 1998, a DOJ Grant Adjustment Notice extended the end of the grant period to Nov. 30, 1998 from May 31, 1998. The program is on schedule for the extended period of performance. Technical objectives are being met, and there are no implementation problems. The technical progress and status at the end of the reporting period is described in the following sections.

Management

During the reporting period, the most significant accomplishment was the completion of a first working model of the handheld ultrasound concealed weapons detector. We demonstrated its performance in a videotape, "Handheld Remote Concealed-Weapons Detector." The videotape demonstrated real-time detection of a plastic knife concealed under a heavy sweatshirt on a person at 7 ft. We believe the ultrasound detector may be the only CWD technology capable of this achievement at this time.

Two Technical Interchange Meetings (TIMs) were held at Jaycor, one on February 26 and one on June 25.

Systems Analysis / Conceptual Design

The conceptual design of the first working model had been refined to reflect findings made during modifications. The following are some of the revised design modifications that were made to the system:

- (1) The audible weapon-indicator was changed to indicate a strong return signal by a speaker tone of rising pitch. A voltage-controlled oscillator keys off the low-pass-filtered voltage envelope to drive the speaker. When the voltage envelope exceeds a threshold amplitude, the speaker emits a tone with a pitch that increases monotonically with the peak of the envelope. Subsequent pulses of greater amplitude during the decay time of the first envelope will drive the speaker tone to higher pitch. The decay time of the envelopes, now 0.2 sec, will be adjustable with a potentiometer in the working models to determine the optimal setting for human factors. We want to match the range of audio outputs to the range of signal voltages, such that an unarmed human in non-reflective clothing produces virtually no signal, and a handgun glint under light clothing produces a loud, high-pitched whistle.

- (2) A row of LEDs was added as a visible weapon-indicator. The indicator is triggered to remain lit for a fixed duration, when a threshold voltage is exceeded on the return signal pulse envelope. The threshold voltage is keyed to range.
- (3) The voltage of a return signal is processed to account for attenuation by range. The receiver gain threshold trigger levels of the indicators are adjusted with range. (In the original breadboard configuration, the receiver gain was adjustable with range (time of flight), but the threshold trigger levels were not.)
- (4) An aiming light was added with about a 12-degree divergence, about 1"-dia. obscuration, sufficient brightness to illuminate a spot on a person in daylight at about 10 feet, and no eye-safety restrictions. The aiming light is a 6-V, 5-W halogen lamp used by police in compact flashlights. The aiming light can be made brighter and less divergent with a smoother reflector and ellipsoidal, rather than parabolic, shape. Pulsing the aiming light was considered to conserve battery power. The aiming light may be strobed at about 30% duty cycle to triple battery life.
- (5) The weapon-indicator electronics were filtered such that reflections from beyond the suspect do not produce false signals. That is, a time gate was added to allow only the first reflected pulse after each transmitted pulse to completely determine the weapon-indicator response. The gate closing corresponds to a fixed period after the return pulse exceeds a threshold, and the gate opening corresponds to some fixed period after the next pulse has begun transmitting, such as 7 ms.

The breadboard device design configuration has been changed to a radar-gun configuration with fixed dish and pistol grip from a garage-door-opener configuration with folding dish. We have settled upon a 5" to 7"-dia. cylindrical lantern-type casing for the detector, with a parabolic reflector of single-piece construction recessed in the barrel. The barrel protects the reflector and the transducer at the focus. The handle is a pistol grip with an on-off trigger. To conserve battery power, the working model has two separate switches for the ultrasound and the aiming light. The prototypes may have a two-position trigger to activate the ultrasound detector when half depressed and activate the aiming light when fully depressed.

The new configuration requires two 3-V lithium batteries to power the aiming light. The aiming light is mounted at the open end of the barrel in front of the transducer. The light performs the dual function of a target illuminator and a bright lantern capable of dazzling eyes even in daylight. The \$29 retail cost of a 6-V halogen lamp and lithium batteries (maybe \$10 to \$20 in quantity) is more than offset by the retail savings of \$50 to \$65 of a comparably equipped police flashlight.

The advantages of the radar-gun configuration are: a familiar grip and configuration for law enforcement officers; the dual use as a dazzling flashlight; and protection of the transducer and dish by the case. The disadvantages are: a bigger, heavier, costlier item, not conveniently carried on a duty belt.

The voltage of a return signal is processed with variable gain to account for attenuation by range, so that a concealed weapon will look the same at 3 m as at 1 m. The receiver gain will be adjusted with range in accordance with the scaling laws we measured. Several Analog Devices AD-600 and AD-602 low-noise, wideband, variable-gain amplifiers were purchased to provide the variable gain as a function of time-of-flight of return signal. Measurements of signal voltage vs. range were used to derive a scaling law and then design the variable-gain of the amplifier.

We purchased two handheld spotlights with 5" and 7" apertures and pistol grips. We modified these to serve as cases for pre-prototype detectors. We extended the barrels of each with sleeves and replaced the insides of each with our custom-made parabolic dishes, transducers, electronics, and batteries. The dishes were machined by the maker of our original dish.

We replaced the high-gain amplifier and switching chips with the Analog Devices AD-600 and AD-602 low-noise, wideband, variable-gain amplifiers.

The 6-V, 5-W halogen Sure-Fire(R) lamp made by Laser Power Corp. is the best off-the-shelf aiming light that we could find. It is used by police in compact flashlights and by the LAPD, according to the LAPD armorer, Sgt. Lew Salcida.

The sleeves that extend the barrel of the spotlights are made of 1/16" aluminum sheet, perforated to reduce weight. Instead of a dual-position trigger for the ultrasound transmitter and aiming light, we will have a thumb-operated sliding switch for the aiming light and a single-position trigger for the ultrasound.

We tried to find a source for a 6" folding parabolic communications dish.

The first working model has an on-off trigger switch for the ultrasound and a thumb-pressure switch for the aiming light. The second working model will have a finger-pressure trigger for the ultrasound and an on-off switch for the aiming light.

Battery power requirements of the working model circuit were measured. Currently, the aiming light works on its own lithium batteries, independent of the rest of the detector circuitry. The circuit will be modified to operate the aiming light and ultrasound circuitry off the same rechargeable batteries.

Testing of the first working model disclosed two system sensitivities: a sensitivity of the transducer to the squeezing of its sides and a sensitivity of false-alarm rate and probability of detection (P_d) to range.

Nearly a year earlier, transducer tests had seemed to indicate that the signal was sensitive to millimeter changes of axial position of the transducer. Recent anomalous test results, later discovered to be due to range dependence, caused us to reevaluate the optical design of the detector. The depth of focus was calculated to be 18 mm, not the 1 or 2 mm that we had supposed from our early tests. In measuring the actual depth of focus of the working model, we

confirmed the calculation. We also discovered that the signal was sensitive not to the axial position of the transducer, but to the tightness of the set screw holding it within its sleeve. The design fix to this sensitivity is to glue the transducer in its sleeve with an appropriate glue and at glue points to be determined.

We had compensated for attenuation with range of the signal by increasing gain with time-of-flight of the return signal. Anomalous test results in detecting concealed weapons led us to understand that although the signal response was "reasonably" flat with range, it was not nearly as flat as it needed to be. The low signal-to-clutter ratio of concealed weapons in most situations leaves only a relatively narrow operating band for the audible and visible indicators. We want the indicators to give no alarm for an unarmed person and the maximum alarm for an armed person with light concealment. Because the response is not flat enough, the working model can only be tuned within these bounds at a particular range within about a foot. The system is now being modified to give a much flatter response at least out to about 10 or 12 feet. It may not be possible to maintain the flat response beyond that range with the current system. A decaying response beyond that range would mean a decaying P_d .

After an exhaustive search of communication-antenna companies yielded no folding dish antennas of about 6" diameter, we decided to proceed building the second working model in the same radar-gun configuration as the first. Significant differences of the second model are: lighter detector with 5"-dia barrel instead of 7"-dia., finger-pressure trigger for ultrasound instead of on-off switch, and on-off switch for aiming light instead of thumb-pressure switch.

Circuit Design

We have designed an op-amp comparator circuit that compares the actual low-pass-filtered voltage peak with a reference threshold level for the purpose of triggering the audible indicator. The circuit for the audible indicator produces a speaker pitch that increases monotonically with the peak voltage in the return signal. The peak detector, an amplifier stage with diodes, feeds the peak voltage into a holding capacitor of an RC network. From the holding capacitor, the charge bleeds out with a decay time of 0.2 s, which is twice the period between ultrasound bursts. The decay time may be adjusted on the breadboard system with a potentiometer for consideration of human factors, such as the perception of the changing pitch of the speaker.

We have also designed a miniaturized version of a pulsed waveform generator to drive the ultrasound transducer. This circuit replaces the pulser and waveform generator boxes that we had been using. The pulsed waveform generator circuit has tunable ultrasound frequency between about 30 and 80 kHz, a variable burst duration (in whole-number increments of wave periods, about 25 microseconds each), and a variable pulse repetition frequency (PRF), now set to 10 Hz.

We have debugged the design of an op-amp comparator circuit that compares the actual low-pass-filtered voltage peak with a reference threshold level for the purpose of triggering the audible indicator. We reduced the original 300-mA current draw by the ultrasound detector circuit (without the aiming light). To include variable gain in this circuit, we have designed a

new circuit that includes a low-noise, wideband, variable-gain amplifier. The Analog Devices AD-602AR variable-gain amplifier replaces several functions of the original circuit. The chip cuts out the transmit pulse from the received signal; of course, it produces a voltage gain that varies with time-of-flight of the received signal in a programmable way; and it conditions the pulse for peak detection.

We produced a schematic of the existing circuits in preparation for improving the circuitry. The goal was to use the Analog Devices AD-602AR variable-gain amplifier to replace several functions of the existing circuit, including the high-gain amplifier and switching functions. Additionally, the new circuit was expected to reduce the current draw from several hundred. We now have all the parts that we need for making these modifications. We are also looking at combining some of the VCO chips that we were using into one simpler circuit.

The circuit has been redesigned to eliminate the need for two of the three gain stages in the original circuit. The tuned filter now gives most of the needed gain in the first stage. Additional gain is now provided by a variable-gain, time-gated amplifier (AD-600 chip), which also has gain as a function of range incorporated in it.

We originally thought that we would have to step the gain as a function of target range in about four steps. Instead, we have designed a circuit using the AD-600 low-noise, wideband, variable-gain amplifier chip to smoothly tailor the gain vs. range. With this circuit design, a calibrated target produces a signal of about the same amplitude no matter where it is between about 4' and 12'.

We have also designed the part of the circuit that eliminates background clutter from behind the targeted person. When the (integrating) return signal rises above a threshold voltage for the first time after a pulse, a gate is held open for a few milliseconds and then shut. After the gate is shut, no more signal can be received until after the next pulse. That few-millisecond gate shuts out all reflections from more than a few feet behind the forward surface of the person. The threshold will be set low enough so that even the weak return signal of an unarmed person is enough to initiate the time gate.

The audible indicator circuit has been modified to produce a rising frequency tone with increasing signal. The circuit has been baselined between an unarmed person (about 300 to 400 Hz tone) and a handgun under light clothing (3500 to 4000 Hz tone).

The interfaces of the switches (on/off, LED-array indicator, audible-indicator volume, etc.) with the circuitry were designed.

The circuit board itself was designed to fit into the plastic housing of the first and second working models.

The circuit design was modified to receive return signals from objects as far as about 45 ft away, instead of the previous limit of about 13 ft.

The circuit design was modified to allow tuning of circuit parameters with potentiometers at three different points in the circuit for the purpose of optimally adjusting the indicator alarm thresholds.

Test and Evaluation

We tested several kinds of aiming lights for brightness and divergence, including halogen lamps, krypton flashlight bulbs, mini-maglights, and laser diodes. All but the laser diodes were dimmer and wider than desired. The laser diodes, involving Class IIIa lasers, were considered too dangerous to point at people.

We made several series of measurements of peak signal return vs. range. The measurements were made on clothing, a pole, a concealed handgun, and a concealed hard plastic card the size of a credit card. Concealment on a human body was by a sweatshirt. The ranges were adjusted to include the 4.5" distance the ultrasound traveled between the transducer and dish, because that distance is included in time-of-flight. Measurements were made between about 4 ft and 12 ft. The ultrasound frequency was 41.1 kHz. The 100-V_{pp} pulses were transmitted for 350 microseconds (about 14 wave periods) at 10 Hz. The return signal voltage was measured out of the amplifier before the peak detector. (We also measured the voltage out of the peak detector, but the processed signal did not give the scaling of voltage with range that we needed to design our variable-gain amplifier.) A best-fit analysis showed that voltage scaled with time of flight (TOF) as the -1.9 power of TOF for the concealed handgun and the pole. The card scaled as the -1.5 power of TOF, because it was more of a specular reflector than the handgun or pole.

We built a test setup for the new circuits to characterize the chips, made sure they worked at 40 kHz, and measured the gain.

We tested the gain vs. range of the amplifier, and found that it maintains a nearly (but insufficiently) constant signal from a calibrated target (a vertical pole on a tripod stand) over the design-to range of 4' to 12'.

We again tested the gain vs. range of the amplifier, but this time in the final circuit of the working model, and found that it still maintains constant signal from a calibrated target (a vertical pole on a tripod stand) over the design-to range of 4' to 12'.

So far, the only tests of the working model in operation have been informal tests to confirm that the audible and visible indicators give negligible signals from an unarmed person and a strong return from a concealed handgun on a person. These tests have not yet been quantified in terms of false alarm rate or probability of detection.

A series of tests were performed to assess the ability of the first working model to distinguish between an armed and unarmed person. A person stood at a fixed distance (7 ft) in front of the detector with or without a handgun or a Lexan knife concealed under a thick sweatshirt or a thin sweater. In all cases, we noted the maximum audible and visible indicator alarms. In all cases, the maximum indicator alarm (most LEDs lit and most continuous high-pitched tone) was greater when the person was armed than when unarmed under otherwise

identical conditions. Not unexpectedly, the distinction between armed and unarmed was greatest for the handgun and was least for the Lexan knife. These results were obtained only at 7 ft. The system is being modified to apply over a broader range of distances.

We tested the sensitivity of the signal to the axial position of the transducer. The theoretical focal length of the parabolic reflector dish is 4.5". A constant target signal was measured with the transducer face at eleven positions from 7.24 mm closer than the focal length to 9.45 mm farther than the focal length. The standard deviation in voltage signal amplitude was only 4.9% as the axial position was varied over this range. The predicted depth of focus of the ultrasound "optics" was 18 mm, which was consistent with these measurements, showing that the signal is insensitive to axial position of the transducer.

We tested the sensitivity of the signal to the tightness of the set screw holding the transducer within its sleeve. A constant target signal was measured at different set screw tightnesses, starting with loose contact of the set screw with the transducer wall. After one full turn of the set screw, further turning of the set screw caused a precipitous drop in the signal voltage, at a rate of about 33% per half turn.

We measured the signal voltage response to a calibrated pole as a function of range from 3 ft to 17 ft. Without any compensation of gain with time-of-flight of the ultrasound signal, the signal voltage from the calibrated pole (and from a handgun glint) decays as the 1.9 power of range. With the gain compensation designed into the circuit of the first working model, the signal voltage decays as only the 0.25 power of range from 3 ft to 9 ft, and somewhat more steeply from 9 ft to 17 ft. But even a decay of voltage as the 0.25 power of range is too much (see "Systems Analysis"). The circuit is being modified to give a flatter response with range.

Systems Engineering

We have considered several kinds of aiming lights. The best for our purposes appears to be a 5-W halogen bulb requiring two 3-V lithium batteries. The need for a bright light and lithium batteries drives the system to a bigger and costlier radar-gun configuration, and away from the garage-door-opener configuration. We are still trying to find a more suitable (brighter, lower divergence) reflector for the bulb.

Strobing the aiming light may be an effective means of conserving battery power and also enhancing visibility of the beam. At no more than 1 Hz and no less than 30% duty cycle, there is little apparent effect on the brightness of a 10-W halogen flashlight bulb. A 30% duty cycle would extend the operating lifetime of the lithium batteries with a 5-W halogen bulb from 1 hr to 3 hrs.

We have ordered lanterns with pistol grips and 5" and 7" bores, suitable to hold our 6"-dia. ultrasound reflector dish. These lanterns were used as the shells of the first working models of the handheld concealed-weapons detector. Additional parabolic reflectors, already programmed by a machinist, will be fabricated for further working models (pre-prototypes). In total, five pre-prototypes will be produced after testing and revision of the first two working models. After field testing of the pre-prototypes, 20 to 50 prototypes will be cast.

The casting of the prototype detectors will be from Autocad drawings converted to Pro-E three-dimensional (3-D) drawings on a floppy disk. From the 3-D drawings, a master copy will be produced by stereo lithography. A mold will be made from the master copy by room-temperature vulcanizing (RTV). The prototypes will be cast from the mold.

We are exploring a new means of rapid prototyping, soft tooling created in silicon molds. These molds are good for an average of 35 parts, instead of the dozen or so of conventional stereo lithography. The greater number of parts matches our requirements for deliverables more closely. The molds can be made in one or two days.

We considered a number of ways of producing the 6" parabolic reflector dish from aluminum, including machining, spinning, molding, and stamping. All approaches seemed to result in costs for the first 10,000 dishes of \$40,000 to \$70,000. In the end we decided the best approach is to injection-mold the dish out of hard plastic along with the detector case.

We have considered modulating the tone of the audible indicator to improve the perception of changing signal strength. The current plan is to increase both the pitch and loudness of the audible indicator with increasing signal strength. The ear has the greatest sensitivity to difference in pitch (the "difference limen") and to difference in loudness at a modulation of 3 Hz. This suggests we should increase the decay time of the 10-Hz received voltage pulses in our circuits to about 300 ms from the current value of 200 ms, and that the audible indicator should be made to warble at about 3 Hz.

The mechanical systems of the first two working models were engineered to integrate and accept the electrical circuit boards and batteries and to interface with them. The plastic housings of handheld searchlights were also modified to allow for installation of the circuit board, reflector dish, and transducer/lamp assembly.

The first working model was disassembled and its components weighed separately. The total weight of the detector with batteries is 3.3 lb (52.5 oz). The weights of the six main components are:

Reflector dish/transducer/lamp assembly	(13.0 oz)
Plastic housing	(10.8 oz)
Aluminum barrel	(8.5 oz)
Delrin ring (joining barrel and housing)	(8.1 oz)
PC board/speaker	(6.2 oz)
Batteries	(5.9 oz)

Even with the same 7"-aperture and configuration, the weight of the detector can be reduced without difficulty to about 2 lb by making the following changes. Weight savings are estimated in parentheses for each change:

- Replace the renboard reflector with a thin plastic dish (5 oz).
- Replace the aluminum barrel with a plastic mesh, since its only function is to protect the transducer/lamp assembly (4 oz).

- Eliminate the delrin ring by making the plastic barrel integral with the housing (8 oz).
- Replace the PC board with a printed circuit board (3 oz).

With a 5" aperture, the weight of the detector in the same radar-gun configuration could be reduced a few more ounces. In the TV-remote-control configuration with a folding dish, the weight of the detector would probably be in the range of 1.25 to 1.5 lb with the aiming light and about 1 lb without. The aiming light is recommended, however, for human factors considerations. (Lt. Sid Heal of the Los Angeles Sheriffs Department (LASD) called the aiming light "a stroke of genius.")

Most of the second working model has been completed, and is just waiting for several parts to be received. The principal differences of the second working model with the first are: (1) The second is smaller and lighter than the first. (2) The second has a finger-pressure trigger for the ultrasound and on/off switch for the aiming light; the first has an on/off trigger for the ultrasound and a thumb-pressure switch for the aiming light. The same circuit board used for the first working model fits within the smaller housing of the second model.

After we have compared the performance of the first two working models, we plan to produce three more and then 20 prototypes. We estimated the costs of producing three more working models, or pre-prototypes, at \$10,000, including parts and fully loaded labor.

We also estimated the costs of producing the 20 prototypes after we have received feedback from law enforcement officers on the five pre-prototypes. Our original estimate for 20 prototypes before the program began was about \$16 K. During the R&D program, we naturally made a number of changes to the preliminary design to improve operational effectiveness or for human factors engineering. Except for the change from two transducers to one, these changes have uniformly increased the weight and cost of the detector. The principal drivers of cost increases have been:

- Radar-gun configuration, instead of TV-remote-control configuration, which may require four molded parts, instead of one.
- Parabolic reflector dish, transducer struts, and protective barrel.
- Halogen aiming light and supporting structure.
- Rechargeable batteries, battery recharger, and easily accessible battery compartment.
- Earplug and jack.

With these changes, and assuming each mold is good for 20 copies, the cost of 20 prototype detectors is estimated to be:

3D engineering design and four molds	\$12.5 K
Layout drawing (Gerber file)	0.8
PC board	4.0
20 boards	1.2
Parts (20 x \$100)	2.0
Assembly, labor (20 x \$456)	<u>9.1</u>
TOTAL	\$29.6 K

Fabrication

The variable-pitch audible-indicator was built and integrated with a single box that contained all the breadboard electronics. A few bugs needed to be worked out before the audible indicator was working properly. The miniaturized pulsed waveform generator was also built and integrated into the breadboard electronics box, and made to work properly.

We revised the circuits and assembled the components of a crude demonstration model for the TIM in February. The demo model did not have variable gain or much in the way of indicators. Nor was it built into a compact, handheld unit. In a limited way, however, it did detect concealed weapons. We also built a strobing circuit for the aiming light.

We had two more renboard 6" parabolic reflectors machined by computer numerical control (CNC), one for each of the first working models. We modified the 7" spotlight with a perforated aluminum sleeve and collar, struts and a cylindrical holder for the transducer and aiming-light assembly and a Delrin-plastic support for the parabolic dish. All the mechanical parts for the 7" spotlight were readied. The battery mounts and placement of switches were completed. We prepared the 5" spotlight in the same way.

The first working handheld detector was fabricated and assembled. The electronic circuitry was breadboarded, and then assembled and installed. The protective barrel was designed, fabricated, and installed onto the housing. We tested the perforated aluminum barrel on the 7"-dia-aperture spotlight to see if stray ultrasound reflections off the inside of the barrel would produce noise in the receiver. It didn't. The signal was no different with the barrel in place than without. Switches, dials, and indicator lights were installed in the housing.

The second working model has been nearly completely fabricated.

Human Factors Testing

We matched the threshold of the audible indicator to the voltage signal return from an unarmed person wearing non-reflective clothing. The audible indicator barely seemed to notice such a person, but gave a clear indication when a slightly stronger signal was returned. We also reduced the amplifier gain to a level at which a handgun concealed under a light sweater would be unlikely to saturate the amplifier. A lightly concealed handgun is expected to be the concealed weapon with the greatest voltage signal return.

We discussed with Gunnery Sgt. Robert Mann of the Marine Warfighting Laboratory the particular needs of the Marines for force protection at perimeters. The application is hostile persons approaching perimeters with concealed handguns or hand grenades and the need for detection at 10-ft standoffs. Sgt. Mann was interested in obtaining a prototype for an LOE demonstration.

We are attempting to get input from law enforcement officers on the concealed weapon detector. An investigator in the Metro Arson Strike Team of the San Diego Police Department (SDPD), B.J. Cavanah, directed us to Sgt. Dave Douglas in the Training Division.

Lt. Sid Heal of the Los Angeles County Sheriffs Dept. (LASD) visited Jaycor on 27 May 1998. He tried the first working model detector when it was not working properly, but seemed favorably impressed anyway. (The detector was fixed by the following day.)

Lt. Heal mentioned three specific potential applications for the ultrasound CWD detector: (1) Searching prison inmates; (2) searching prison visitors; and (3) searching "gangbangers" congregating on the streets. He felt that part of the value of such a detector would be in inducing "behavior modification," which would be an indication to the officer of possible concealed weapons or contraband.

For the first generation of concealed-weapons detectors, Lt. Heal said that false-alarm rate was not an issue to be overly concerned about. As the CWD technology improves, the courts' standards for reasonable search will rise accordingly, and older, less-capable technologies will become obsolete and be replaced by improved technologies.

Our next input from law enforcement officers will probably be from Sgt. Dave Douglas in the Training Division of the San Diego Police Department (SDPD), after he recovers from surgery.

The head of the Japanese National Police Agency (NPA) has told a Supervisor to make it a high priority to learn the capabilities of our detectors. The Japanese want to have a device so small that it is nearly unnoticeable in the hand.

Testing revealed the need for a very flat signal response with range. Also, the sensitivity of the response to glint angle suggests that achieving a good P_d will require examining each area of a suspect's clothing from a range of angles to catch the glints. This feature, more than power, may be what limits the effective range of the detector.

Plans for Next Reporting Period

We will complete the second working model and compare the performance and human factors of the first and second models. Based on this comparison, design decisions will be made for the final three pre-prototypes. Parts will be ordered and production of the final pre-prototypes will begin. Three more pre-prototypes will be built by mid-to-late September, 1998. The five pre-prototypes will be delivered to NIJ for evaluation and feedback from law enforcement officers. After the feedback to the pre-prototypes has been evaluated by Jaycor, the designs will be modified as necessary, and prototypes will be produced. Even before the five pre-prototypes are completed, however, we hope to get some preliminary feedback from SDPD and LASD officers.

Before the pre-prototypes are considered ready for delivery, a technical modification must be made. We will flatten the signal response with range at least out to about 9 ft, and farther

if possible, so that the detector responds almost exactly the same to a concealed weapon at 1 m as at 3 m. In validating this modification, we will be making ultrasound reflection measurements on weapons and calibrated targets.

We will also perform validation testing on unarmed and armed persons with the handheld detectors to quantify false alarm rate and probability of detection of weapons under various kinds of clothing.

We will meet with Japanese representatives interested in the ultrasound detector and with the NIJ Program Manager and director of the office of Science and Technology. We will demonstrate the detector to the Japanese National Police Agency (NPA), once the demonstration has been approved by the NIJ. And we will demonstrate the detector to any law enforcement officers suggested by NIJ.

A technical paper, "Handheld Ultrasound Concealed-Weapons Detector," will be prepared and presented at the SPIE Symposium on Enabling Technologies for Law Enforcement and Security in Boston this November. This paper and the two Categorical Assistance Progress (CAP) Reports will form the basis for the final report.

PROPERTY OF
National Criminal Justice Reference Service (NCJRS)
Box 6000
Rockville, MD 20849-6000